

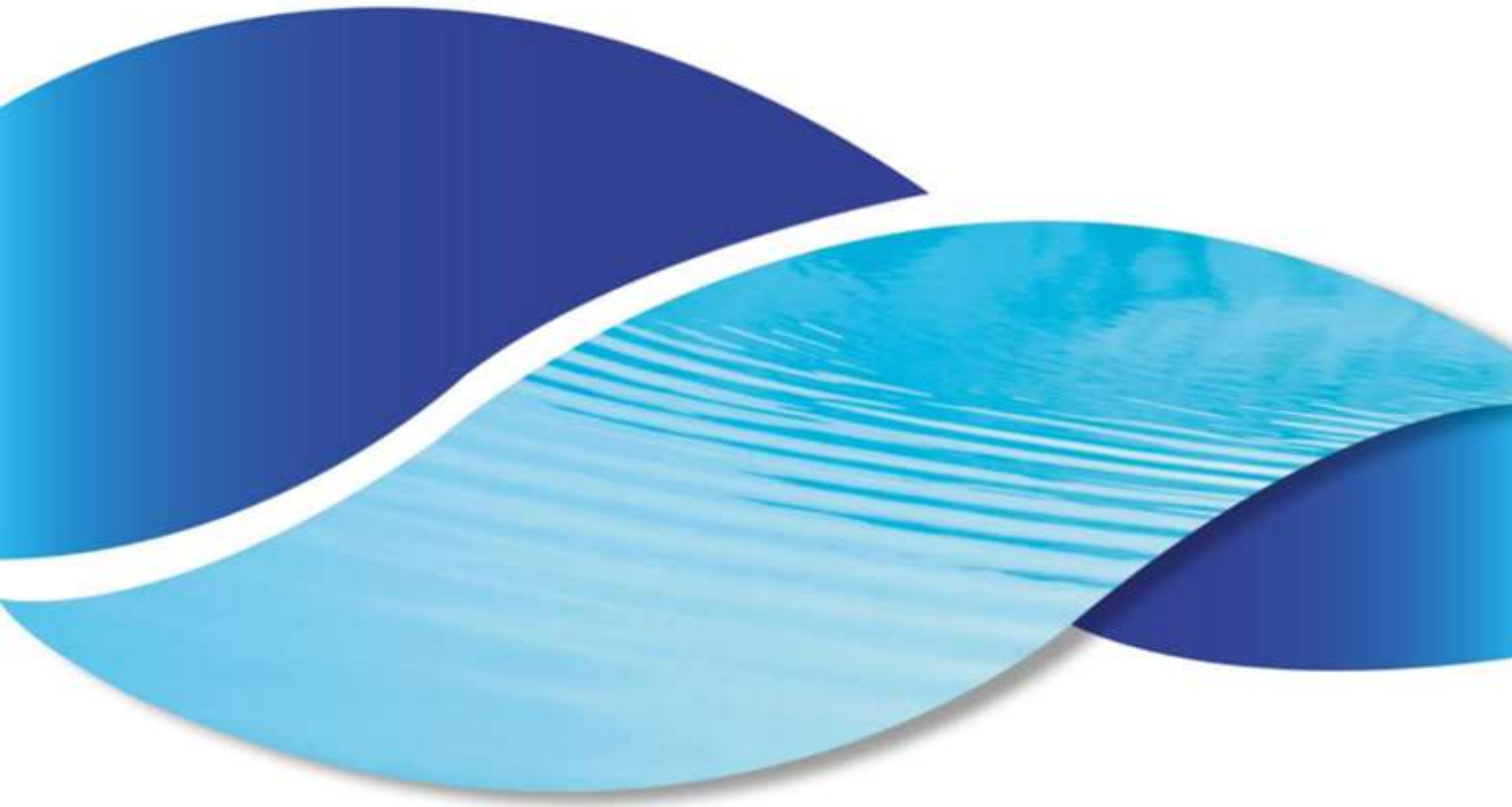

BENIFERRO.eu
plug & play products



Wifipool Water Treatment with Liquid/Acid Chlorine GEN 2 Complete manual



Table Of Contents

Introduction.....	3
Safety warnings and instructions	4
Specifications.....	5
Pairing and setup instructions	6
Installation instructions	10
Operating instructions.....	12
Chlorinator Operation	18
Checking chlorinator output	22
Four factors directly affect the chlorine production:.....	22
Salt chlorine generator production test:.....	22
THE OPERATING ENVIROMENT AND MAINTANCE OF SALT ELEKROLYSE	22
The operating water environment of the salt chlorine generator	22
Pool water salt concentration adjustment and maintenance	24
The stabilizer needed for each ton of water to be kept at 75ppm (0.0075%). unit: kg.....	26
Maintenance instructions	27
Maintenance of the water treatment.....	27
Anti calc.....	28
How to prevent scaling of injection nipples?	28
How to de-scale the injection nipples?	29
Maintenance of salt chlorine generator.....	32
Winterizing and spring start-up instructions	33
Winterizing the system.....	33
Spring start-up	33
Troubleshooting.....	34
Troubleshooting Wi-Fi / app related problems	34
Deviation of the pH measurement compared with another method.	34
Deviation of the Redox measurement compared with another method.	35
Troubleshooting for the peristaltic pump	35
App problems	38
Salt Electrolyzer	39
Wiring diagram.....	41
Connecting level switches	43
.....	43

INTRODUCTION

The “Wifipool DUO” is used to monitor and control pH, and Redox (chlorine), of your swimming pool. pH and redox (chlorine) are measured continuously. If pH is too high, or chlorine levels too low, it will automatically pump liquid pH- or Chlorine in the swimming pool. The Salt electrolysis will also measure the conductivity.

The equipment is designed to monitor and control the pH and redox content (chlorine) of your swimming pool. This guide provides information necessary for installation, troubleshooting, and maintenance. Please read the entire manual on www.beniferro.eu before installing and commissioning the product.

To install and use the measuring and control box, you need to follow a series of steps:

1 Installing the Wifi Pool app

2 Connecting the measuring and control box to the Wi-Fi network and to the telephone

3 pH and RX calibration and automation of pH and RX adjustment



This manual contains all the necessary information for installation, troubleshooting and maintenance. Read the manual thoroughly before opening or using the unit. The manufacturer of this product will not be held responsible for any injury to and/or damage of the product resulting from improper installation or unnecessary/incorrect maintenance. It is essential that the instructions in this manual be always followed.

SAFETY WARNINGS AND INSTRUCTIONS

General

- Installation personnel should read this manual carefully before proceeding with installation. In case of incorrect use, contact your provider.
- This appliance is not intended for use by persons (including children) with reduced physical, sensory or mental abilities, or lack of experience and knowledge, except under the supervision or instruction of a responsible person regarding its safe use.
- Improper installation can create an electrical or chemical hazard, resulting in serious injury.
- Always wear gloves and safety goggles when working on the facility.
- If you are not familiar with the pool filtration system and dispensing equipment:
 - Read all installation and operating instructions before using dispensing equipment.
 - Only a qualified installer, center, individual, or authorized dealer can repair this product.
 - Never change anything without consulting your supplier, a professional pool contractor.
 - In case of damaged parts, use only original spare parts. Failure to do so will void your warranty.
- Maintenance and use should be performed in accordance with the recommended time and frequency as indicated in the manual.
- Do not install the device in an area where the electronic may be damaged by moisture or rain.
- Install the water treatment unit on a solid base or against the wall (always vertically).
- Always keep the product in an upright position. If the product is tilted or placed on its side, the probes will not be able to measure properly, resulting in incorrect readings.
- In case of damaged parts, it is preferable to purchase replacement parts from the manufacturer. Use only original standard parts. Failure to do so will void your warranty.

Electrical

- Disconnect all power supplies during installation or during any other operation on the equipment.
- It is recommended that the water treatment unit be installed in a bypass configuration so that:
 - Chlorine and acid pumps cannot operate if the filtration pump is not working. This can be done by purchasing a metering device with a flow switch, adding a flow switch to the facility, or using the same or shorter timer than the filter pump.
 - Chlorine and acid pumps can be turned off manually. This can be done by using the on/off button at the bottom of the dosing pump or via the manual control of the app.
- If a frequency converter is used, we recommend to locate it at minimum 3m from the dosing unit, to use a separate electrical circuit for the converter and the pH/RX pumps unit and to verify interactions between frequency converter and pH – Redox measurement (verify that pH and Redox do not deviate when switching on-off the convertor).
- All external power supplies and adapters for pool equipment must be connected to a power source with 30 mA residual current protection.
- Make sure all equipment and pool water are properly grounded. The pool hose is grounded via an in-line grounding to an independent grounding pole.
- Before performing any maintenance or operation, make sure all electrical equipment (the peristaltic pumps, salt electrolysis etc ..) are disconnected and the "OFF" position. switch off the power source.
- NEVER make adjustments inside the equipment.
- Our devices do not have an audible alarm, only an on-screen alarm.

Chemical

- Keep the installation and chemicals out of the reach of children. Always wear safety gloves and goggles when working on the installation.
- Calibrate pH and Redox probes before first use and at least every 3 months thereafter. Check the chlorine level and pH "regularly" with a high quality color method.
- The addition of pool chemicals should be done downstream of the pool accessories such as the water heater, UV lamp, filter and downstream of the measuring probes
- Chlorine and acid react



together to form toxic chlorine gas. Make sure the chemicals are placed outdoors or in a very well-ventilated area, in a drip tray, that they cannot come into contact with each other, and that they are kept out of reach of children...

- Make sure water or chemicals cannot drip onto the installation. Do not place equipment under the dosing system. Dripping of Chemicals onto equipment will not make part of a guarantee compensation.
- Have 2 sumps underneath the equipment to collect leaks at peristaltic pumps and injection nipples. Sump pans should be positioned so that chlorine and acid leaks cannot mix.
- Repair leaking pipes immediately. Do not operate equipment with leaky pipes.
- Only use liquid chlorine with anti-scaling precipitation agent.
- For Chlorine injection leakage, please read the scaling cleaning chapter in the full manual.
- Make sure the machines you use are programmed so that acid and chlorine are never added at the same time.
- The acid dispenser should not be used with hydrochloric acid (HCl).
- Use only liquid chlorine approved for swimming pools and with anti-calc remover, or add an anti-calc remover to liquid chlorine.
- Use a maximum of 14.99% sulfuric acid as the min pH.
- Make sure the chlorine container and the acid container are not confused. Make clear markings on your installation and on the chemicals.
- Do not allow children or unauthorized persons to reach the chemicals.
- To ensure proper operation of peristaltic pumps, check the pumps weekly for leaks. In case of leaks, please refer to the complete manual of your installation on www.beniferro.eu
- Ensure that the measuring probes remain consistently moist during transportation, especially when being transported for maintenance or repair work at the supplier's facility. Flush all lines with water before dismantling the equipment.

SPECIFICATIONS

Model description	Pool size	Output	Mounting	Flow switch	Level switch
BWPX7065	2 to 125m ³	42g/h	DIY	yes	no
BWPX7066	2 to 150 m ³	42g/h	DIY	yes	yes



Dosing capacity

The dosing capacity can be regulated with the “duty cycle” down to 1 % of the normal dosing velocity. Therefore , the Pool size has a wide capacity : from 2m³ to 150 m³. On demand, Beniferro can use dosing pumps with higher dosing capacity (up to 1000 m³ swimming pools)

PAIRING AND SETUP INSTRUCTIONS

Carry out pairing and setup before physical installation, indoors in a environment with a ethernet connection and a strong wifi signal of the future swimming pool wifi network

Setting up the wifi connections

- **Install Wifipool app**
Install the Wifipool app on your telephone. Read the wifipool app manual for details.
- **Pair your equipment**
Pair the pH/RX equipment to your home Wi-Fi network and your phone. Read the Wifipool app manual for details. Perform the pairing in-house, using a ethernet cable of close to the Wi-Fi router and before physical installation. Read the wifipool app manual for details.

Ethernet connection on the box →



The automation is embedded in the app when pairing the equipment to the mobile telephone. Also the wheel settings and symbols will be entered into the system.

The pH- pump will work if:

- o pH > 7,6 AND
- o Flow = true
- o pH drum is not empty (only if level detection is present)

The RX-pump will work if:

- o pH ≤ 7,6 AND
- o RX < 700
- o Flow = true

The standard fail safe setting is : “off”: in case internet connection or server connection is lost, the fail safe will stop all dosing devices.

The automation can be adjusted manually. Consult the Wifipool App and simple device manual on how to do this.

Here are some recommendations for expanding your automation

- Create a scheduler-snippet to define the time during which the pH pump and RX pump can run. Make sure the automation starts 15 min after start-up of flow, to make sure the pH and Redox probes are in equilibrium before starting the chemical treatment. Stop the pH pump and RX pump timer before filter pump shut down.
- Create a notification scheduler, and make sure the water treatment has had the opportunity of reach equilibrium. Set notifications if
 - pH<6 or >8
 - RX<500 or > 900
 - No flow or pH drum empty

The principle of snippets can be found in the [Wifipool App and simple device manual](#).

Alternative method for entering the automation

The automation is set via the Wifipool app and can be set via three methods adding existing automations, scanning or manual entry (or a combination).

Access the automation page via the Pool settings page -> automation and setting page.

1 existing automation

The first method is to add existing automations. You can do this by pressing the plus icon, selecting the existing automation module, and then choosing either PTFLS or PFFS.

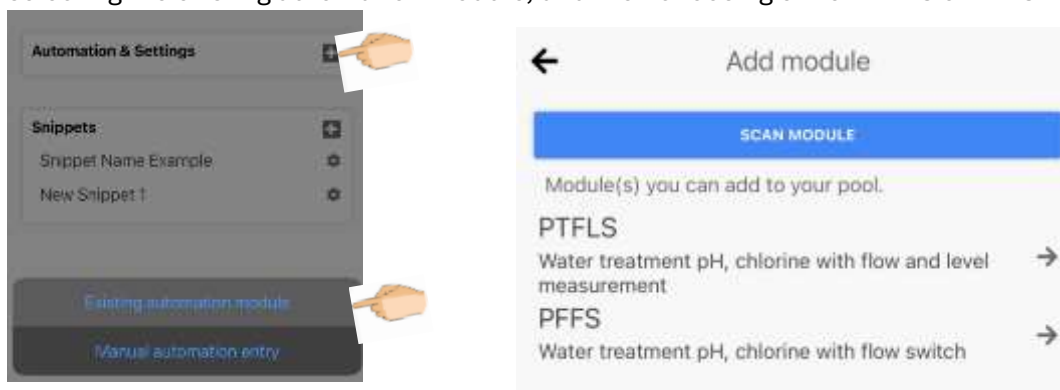

The difference between PTFLS and PFFS:

PTFLS:

- **pH module > 7.6, flow switch detects flow, and level switch is high:** This will enable the pH pump.
- **RX < 700, pH < 7.6, flow switch detects flow, and the second level switch is high:** This will enable the RX pump.

PFFS:

- **pH > 7.6 and flow switch detects flow:** This will enable the pH pump.
- **RX < 700, pH ≤ 7.6, and flow switch detects flow:** This will enable the RX pump.

2 automation via scanning

For additional information regarding automation features and setup via scanning, please refer to the Wifipool and Simple Device manual. These comprehensive guides provide detailed instructions and insights to help you maximize the functionality of your Wifipool system.

- 1) Press + on “Automation and settings” (Pool settings page) and choose « Existing automation.

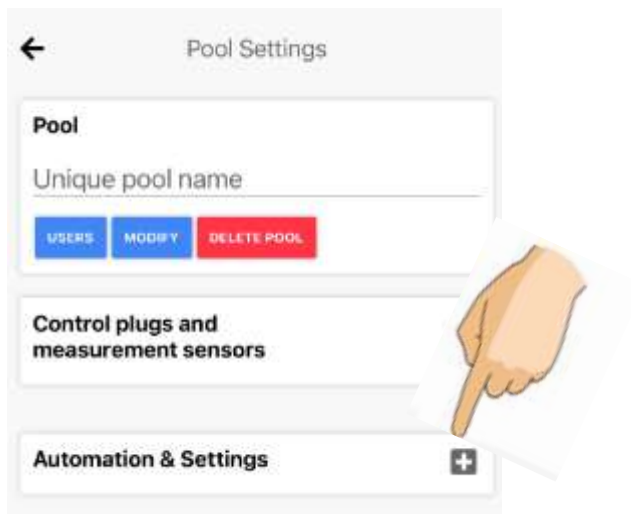

- 2) The app will ask to scan an automation barcode.
- 3) Select the correct automation below, and scan it with your phone.

<u>Barcode</u>	<u>Module Description: Combined pH + RX Control</u>
pH and RX without flow switch PTS	
pH and redox control, flow switch but no level switch PFFS	
pH and redox control, with flow and level switches PTFLS	

The pH- pump will work if:

- o pH > 7,6 AND
- o Flow = true
- o pH drum is not empty (only if level detection is present)

The RX pump will work if:

- o pH ≤ 7,6 AND
- o RX < 700
- o Flow = true

3 automation via manual entry

Enter the conditions described above, manually into your Wifipool app.

Consult the Wifipool app and simple device manual for details.

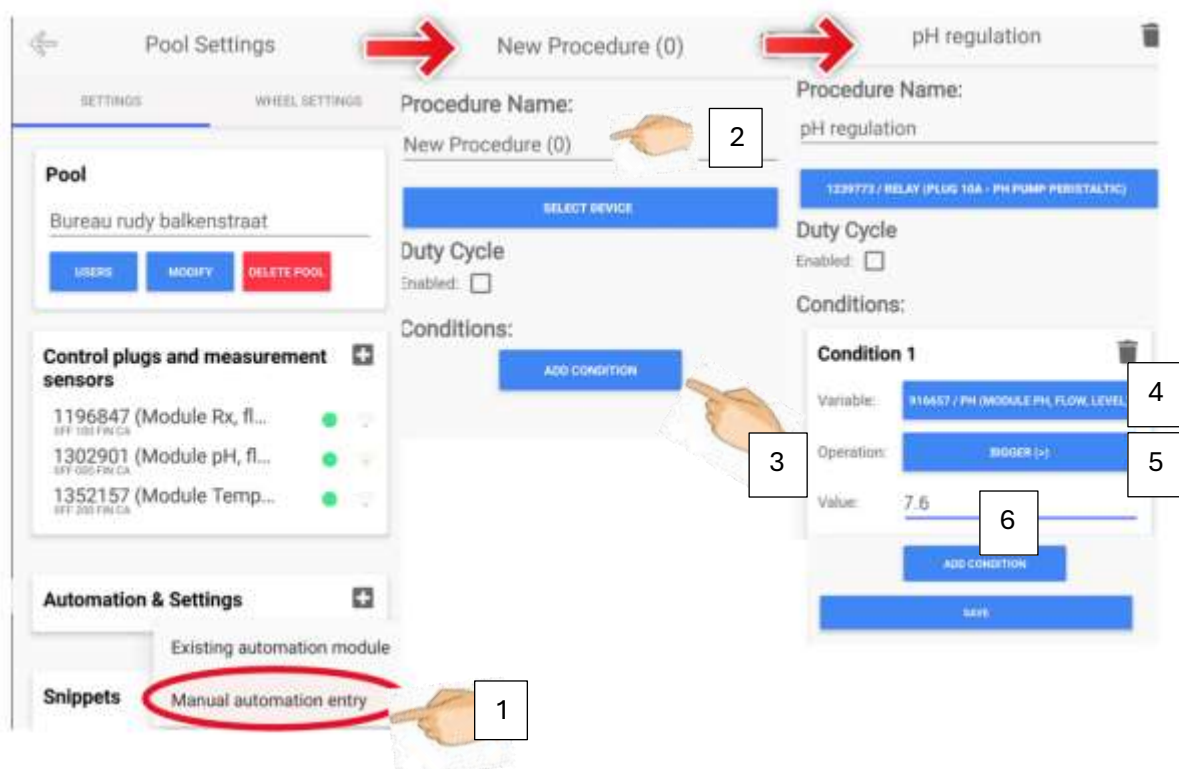

1. To add a manual entry, simply tap the plus icon and select "Manual Automation Entry." This will initiate a new procedure.
2. Ensure to rename the procedure to a more fitting title.
3. You can incorporate conditions by using the "Add Condition" icon.
4. Select the appropriate variable (e.g., pH level).
5. Choose an operation (e.g., greater than, smaller than...).
6. Specify a value. While the recommended pH level is 7.6, you can manually adjust it to suit your preferences.

INSTALLATION INSTRUCTIONS

General

The factory supplies the water treatment unit electrically connected and, in some case, already mounted on a plate or in a box. Modification to the unit has to be made by trained personnel, knowledgeable about swimming pool technology and electrical systems. The attention points below must be respected.

Read the Safety instructions and warnings before proceeding with the installation

General installation recommendations

- Fix the water treatment unit on a solid base or against the wall (always vertical).
- The product must be installed indoors in a dry, warm and well-ventilated area. If you want to do this outside, the unit will need to be sheltered from rain and direct sunshine.
- Install the water treatment after pump and filter, and after all accessories such as UV lamp, heating, ionization ...
- Connect water inlet and water outlet, so that the water passes first along the Redox and pH measuring electrode and then along the pH and chlorine injectors.
- To connect the pipes, use only line that is suitable for gluing PVC.
- Optionally you can add level switches to the installation. The level switches will stop dosing of the pH / Chlorine liquid, when the liquid level in the drum is "low".
- Install the electrolytic cell on the bypassed pipes after filtration of the pool cycling pipe system. And an adjustable valve must be installed in the main pipe. (see figure 1).

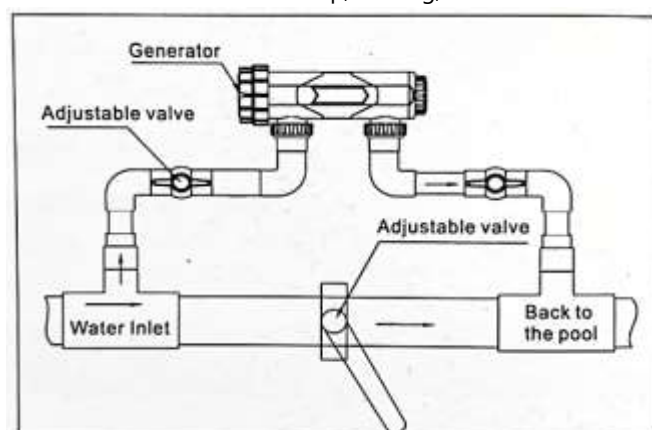

Figure 1

Install the different elements in the following order:

1. pH and RX measurement
2. pH and RX adjustment

Make sure following requirements are met:

- Always keep the product in an upright position. If the product is tilted or placed on its side, the electrodes or flow switch may not be able to measure correctly. Flow switch, pH and redox electrodes must be placed vertically in a horizontal pipeline. The flow switch must be oriented in the direction of the arrow on the switch. The pH and Redox probes have to be in a horizontal line, at a maximum angle of 45°.
- For the measurement and distribution tube : make sure the flow direction is :
 1. Flow through measurement probes
 2. flow through dosing nipples
 3. Flow switch must be installed in the same line as the dosing nipples.
- Make sure pH / chlorine adjustment cannot work if there is no flow through the pH injection / chlorinator pipes. This can be done by using a flow switch and/or by connecting the electrical connections of the dosing pump / chlorinator to the same electrical line as the filter pump.

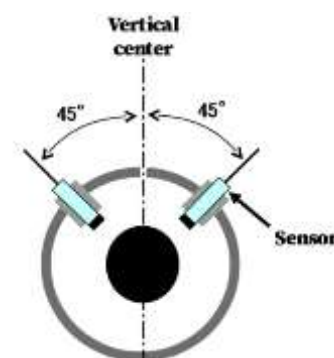

- If you live in a area with high water hardness, it is advisable to attach a 5-10cm long tube (use part of the peristaltic aspiration tube) to the injection nipple.
- For product supplied in a box, additional 2 inch and 32-38mm connectors are supplied to fit the typical intex / Bestway or other aboveground swimming pool connections.



- If you do not have a flow switch on the unit, adjust the electrical connections so that The chlorine and acid pumps cannot work if the filter pump does not work. The electrical 230V feed to the wifipool control box must loose power as soon as the filter pump switches off.

•

The chlorinator should be mounted in a well-ventilated, dry, and shady location, so it is not exposed to drain or direct sunlight. And the power pack should be mounted onto a post or wall 1.5 meters above the pool water, to ensure the gap surrounding no less than 100mm, with sufficient ventilation for its heat dissipated. The left side of power pack is for cooling exhaust, where should not be blocked or too close to other equipment to affect its heat dissipated. Using the template supplied in this Manual, mark two holes distant 180mm for fitting the Power pack to the wall, drill two holes for fixing 2 pieces M8 screws, align two holes of power pack backside and push it down for fix. HINT if fitting against a limestone wall, use a piece of wood as backing to prevent corrosion of the Power Pack bracket. Connect the 2 red and 1 black electrode contact to the two poles of the generator, 2 (+) pole tip and 1 (-) pole tip correspondingly; then connect the control box and the generator with the water level / temperature joint wire correspondingly. (see figure 2 / 3).

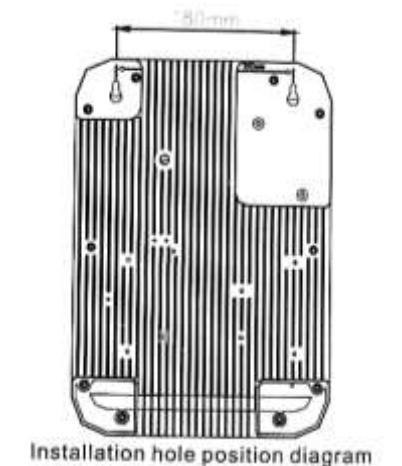

Figure 2

Note: The chlorinator must be supplied by power supply with a leakage switch (AC220V-240V/50Hz, 16A), and supplied through a residual current device (RCD) with a rated residual operating current not exceeding 30mA.

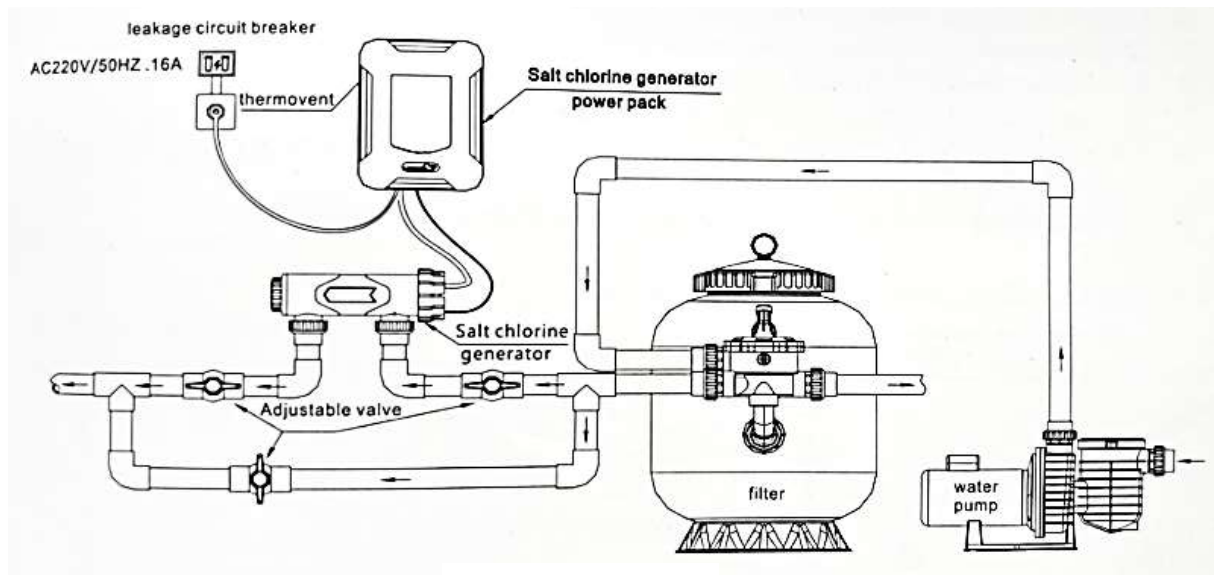

Figure 3

OPERATING INSTRUCTIONS

General instructions

After pairing and physical installation of the unit, we are ready to start calibrate, leak-test and start-up the unit.

- Before using the equipment, pH and RX probes have to be calibrated
- The measuring probes must always be kept moist during transport. A small box containing fluid is provided for this purpose, ensuring the integrity of the product. Prolonged exposure to dry conditions can lead to inconsistent measurements and/or broken probes . For any maintenance and repair work, please ensure to keep probs moist.
- Use only city water, no rainwater or well water.

Calibration

- The pH and Redox probes must be calibrated regularly, and the correct functioning must be verified by means of a high quality color measurement method (e.g. Poollab)
- Connect the pH and redox measuring heads to the BNC connection (figure 4-5) in the positions provided for this purpose: pH probe (blue connection) on the left (or top) , RX probe (red) on right or bottom.

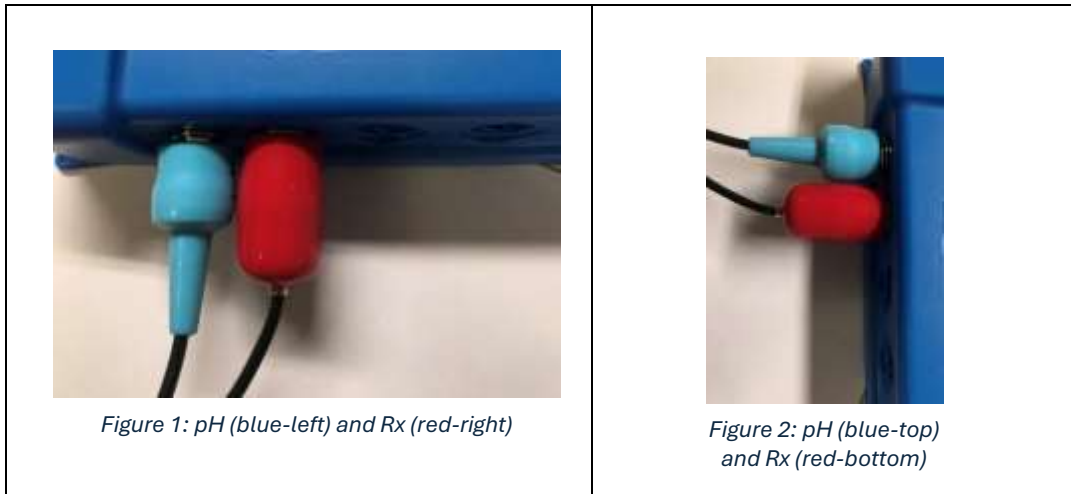

- During calibration we make sure pH and Redox (RX – chlorine) probes are correctly measured. Calibration needs to be done at the start of the swimming pool season, and on a monthly basis during normal operation and in case of doubt on water quality. Verify pH and chlorine content of your pool regularly (we advise each 2 weeks to do a color-test using a high quality instrument such as the Poollab from Water-ID), recalibrate and/or adjust setpoints as required.
- Before calibration, make sure you have the calibration solutions for pH and Redox ready.
- Via the Pool settings / “Control plugs and measurement sensors” module, you can start off the calibration process.
- Go to the “Pool Settings” page, and upon ticking your module, and a submenu will appear. Simply select "Calibrate pH Pump" or "Calibrate RX Pump" to initiate the calibration process.

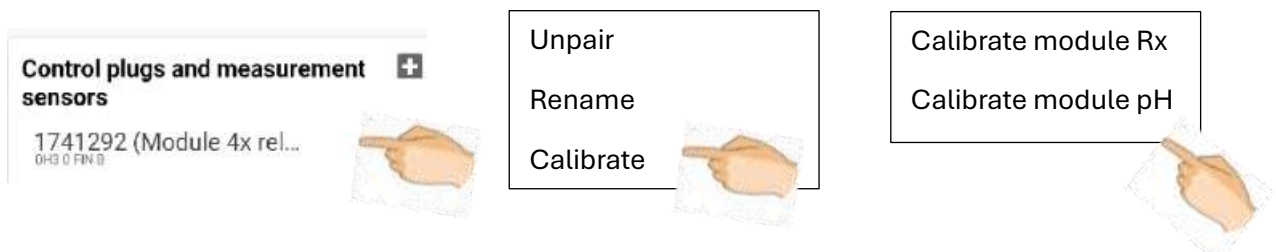

- The calibration process will take +- 3-4 minute per probe, and the app will indicate whether the calibration was successful or not.

Leaktesting and leak management

Insert the pH and RX probes after calibration and put water pressure and flow through the unit.

Insert pH and chlorine electrodes into the electrode holders. Fix the nut with pliers or wrench while tightening the cap.

At start-up of the leak test, do not switch on electrical power to the water treatment unit.

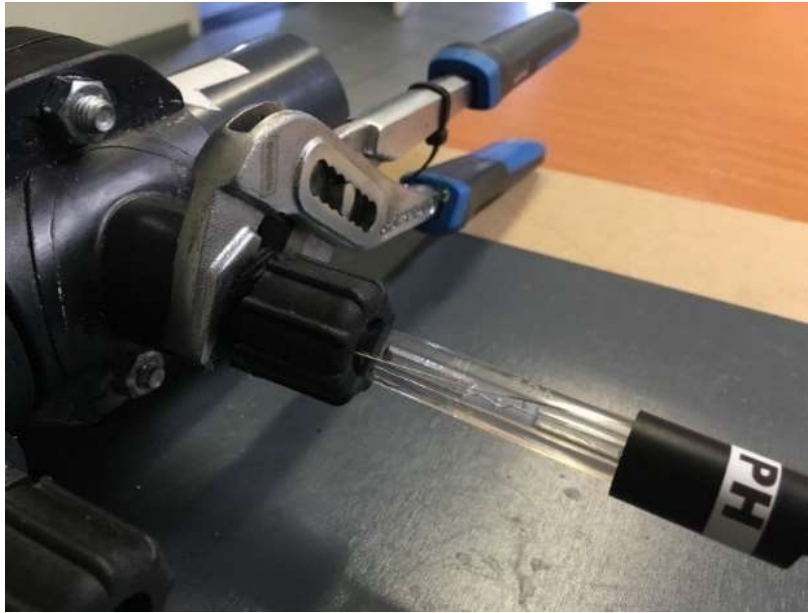

Leaks must be repaired immediately.

Make sure leaks of sulphuric acid cannot mix with leaks of the Chlorine dosing outlet, as they may cause formation of toxic chlorine gas.

Make sure leaks cannot run over (other) parts of the swimming pool equipment.

Make sure leaks are captured into a separate container or drip tray.

Start up

Start up the filterpump, and switch on the power to the water treatment unit. As soon as flow is detected, the unit will start up.

Consider starting up the water treatment 15 min later than the filter pump by using a scheduler.

pH and RX setting

We recommend to set the pH at 7.6. The chlorine contains pH+ and the pH will rise. This is compensated by adding pH – via a dosing pump. When pH setting = 7.6, the pH will – in case of overshoot – very likely remain in the correct pH 7.2 – 7.6 operating range.

The real criterium for safe swimming pool water is to have a pH of 7.2 – 7.6 and a free chlorine content of 1 +/- 0.5 ppm. The free chlorine is very difficult to measure continuously online, hence the redox is used.

The Redox is a measurement of the oxidation power of the swimming pool water. The higher the redox, the more “aggressive” the pool water will be towards bacteria and algae in the water.

The redox measured depends on many variables (such as chlorine content, type of chlorine used additive content, electrode lifetime ...) and is different for each pool.

Usually, a Redox value of 650-750 mV corresponds with 1 ppm chlorine.

Once the pH of the system is balanced, you will need to measure the free chlorine content of your pool using a proper coloring method (e.g. via a Pool Lab). If this is < 1ppm, you should increase the RX setpoint (in 10mV increments) until you measure 1ppm of free chlorine in the pool. If the free chlorine level is higher than 1ppm, reduce the RX setpoint (in 10mV increments) until you measure 1ppm of free chlorine in the pool.

Hysteresis

A pH and RX hysteresis has been programmed, to avoid fast and repetitive start-stops of pH pump or RX Pump

pH Hysteresis is +/- 0.04

RX Hysteresis is +/- 10mV

This means that pH may be over or under the target value by 0.04 units, without the pH pump being activated or stopped.

RX value may be over or under the target value by 10mV, without the RX pump being activated or stopped.

Deviation of the pH measurement compared with another method.

When working with probes, one must accept the following as true:

- In principle, a calibrated probe measures correctly, more correctly than a color method.
- A probe that calibrates itself works
- The color method works correctly, only if the alkalinity of the water is correct
- A difference of 0.2 between two methods is normal, a difference of 0.5 is not acceptable.
- A simple measurement of droplets does not give reliable results

Here are the steps to follow in case of doubt about the pH:

In case of opposite pH measurement (one method gives an acidic result, the other method gives a basic result):



Take a glass of water and add 2 tablespoons of vinegar. Both methods must measure an acidic pH. If the probe gives a pH > 7: add 10 spoonfuls of vinegar and see if the pH rises or falls. If the pH rises: contact the sensor supplier

After this verification:

Always take samples in the pool just before the skimmer, so that the sample corresponds to the water passing by the electrodes.

1 Recalibrate and remeasure pH with probe. If in doubt:

2 Check and adjust the alkalinity of your water between 80 and 120 and remeasure the pH with your color method. If doubt remains

3 Renew the pills/liquids of your measurement tool and remeasure the pH with your color method. If doubt remains :

4 Buy a new calibration solution and measure pH with probe. If doubt remains

5 Buy a certified pH 7.4 solution and measure pH with a probe. If the pH of the probe is between 7.2 and 7.6 accept the probe. If the measured pH is 7.0-7.1: check the pH at 7.6. If the pH of the probe is 7.7-7.8: control the pH to 7.2. If the pH is lower than 7.0 or higher than 7.8: contact your supplier (Pool Duo supplier as well as the supplier of the alternative method).

Deviation of the Redox measurement compared with another method.

A deviating RX value is not so bad, as long as the probe is sensitive to changes and the redox increases when more chlorine is added to the pool.

You can test this by mixing 5 drops of liquid chlorine in a bucket of water and measuring the redox before and after adding the chlorine. Due to the 5 drops, the Redox must rise significantly.

A deviating redox can be caused by a deviating pH and/or by "contaminants" in the swimming pool such as flocculant, anti-algae, wall cleaner, etc ...

A deviating redox is not so bad. You proceed as follows: measure the free chlorine content in the pool using a color method (before measuring the chlorine content, the pH and hey cyanuric acid content must be within specifications). Add chlorine to the pool until the chlorine level is 1-1.5ppm. The redox that you then read is the redox that you must set as the setpoint.

If you still have doubts about the redox value you have read, you can proceed as follows:

1 Change calibration fluid and recalibrate the device. If you still have doubts about the redox value read:

2 Exchange redox probe and recalibrate.

Reducing pH dosing speed and Chlorine generation intensity for small pools or SPA

The pH / chlorine dosing speed can be reduced by adjusting the Duty cycle in the pH and RX automation sheet.

In the example where the duty Cycle is 33% per 60 seconds, the pH pump will dose 33% of 60 seconds = 20 seconds each minute.

Using the duty cycle can reduce the “overshoot” (adding too much pH correcting agent) in small swimming pools or SPA’s`



Attention:

For the pH peristaltic pumps, we recommend a duty cycle of 60 seconds which is set at :

- 80% for pools of 35-45 m³
- 60% for pools of 25-35 m³
- 40% for pools of 15-25 m³
- 20% for pools of 5-15 m³

We recommend not to set the duty cycle for pools > 45m³

CHLORINATOR OPERATION

1. After installation, supply the power to generator, the "Power" indicator will be lit and the LCD display will show the time and the water temperature inside the generator.
(Details as follows)

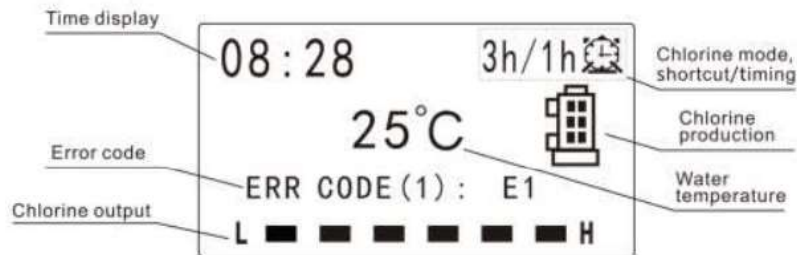

Displayer with automatic screen saver function, it's off in the absence of operation delay 3 minutes, press any key to active the light.

Remarks:

- Time display: show the local time.
- When the underwater light is on, a light icon is displayed.
- Circulation pump: when circulation pump is on, dynamic icon is displayed.
- Chlorine mode: shortcut or timed chlorine control.
- Error code: when the work is abnormal, the corresponding fault code is displayed.
- Chlorine production: this icon indicates chlorine production.
- Chlorine production: "L" low chlorine production, "H" high chlorine production, the more "-", the the higher chlorine output.
- Temperature display: show the water temperature inside the generator.

2. Function settings interface, as shown below:

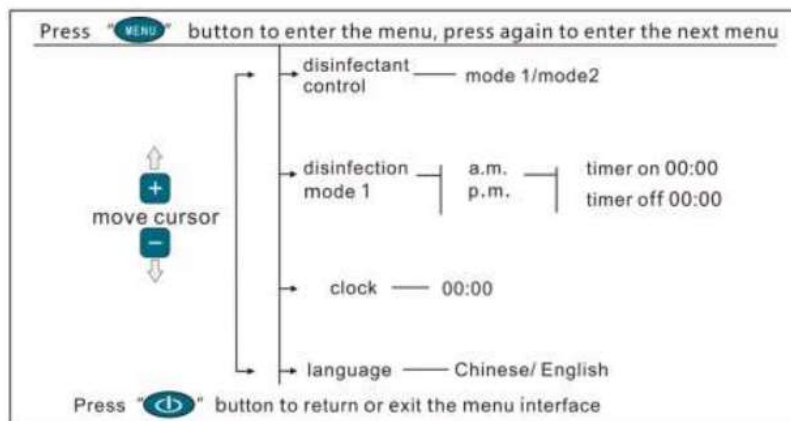

3. Function settings

a. Language:

Language selection, enter the menu interface, move the cursor to language, Press “view” to enter, press -/+ button to choose Chinese or English. (see figure 4).



Figure 4

b. Setting the clock:

The generator inbuilt with clock function. The initial use should set the local time. Press the “view” button to page 2/2, Move the cursor to Clock, Press “view” button to enter time setting Press the power button to select the setting clock Hour and Minute. Setting the Clock by -/+ button. (24 hours system).

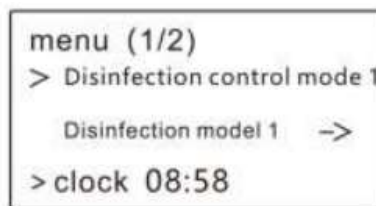

Figure 5

c. Chlorination cell on based upon the programmed times for Timer-1 and Timer-2.

Timer-1: automatic control of chlorine production by present time

Timer-2: permanently switch pool pump and chlorination cell, thus overriding the timing function.

d. Press the “view” button to page 1 or 2 (shown as follows). Move the cursor to chlorination by -/+ button press the view button, select timer-1 or timer-2 by -/+ buttons press the view button to save setting.

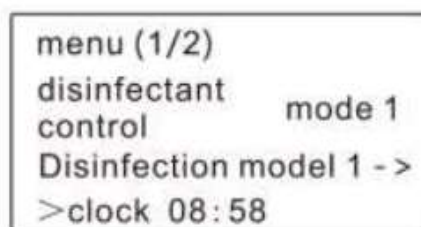

Figure 6

e. When set Timer-1, the start time and end time setting are required, divided into morning and afternoon. Press view button to page 1/2. Move the cursor to Timer-1. Press view button into morning time setting (shown as figure 9). Press view to set the start morning session running time by +/- buttons (1-12 hours), same to set end time (shown as figure 8). Save and back to clock LCD, is shown, as (figure 7). Timer-1 is running. Note: end time must be larger than start time, or system defaults no setting time.

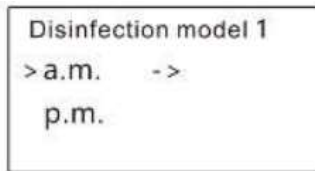

Figure 9

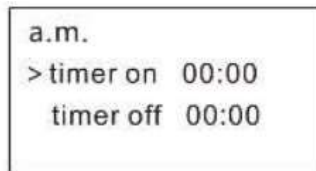

Figure 8

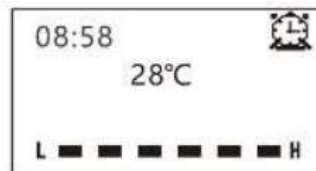

Figure 7

f. When set Timer-2, Display cycle time above the display screen "2h/1h" as figure 10. And for 3 kinds of periodic time choice, press restart button, Select switch.

- a. 2h/1h: recycling of operation for two hours and breaking one hour.
- b. 3h/1h: recycling of operation for three hours and breaking one hour.
- c. 4h/1h: recycling of operation for four hours and breaking one hour.



Figure 10

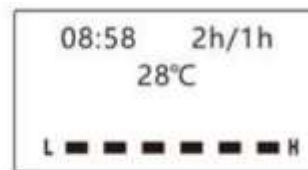

4. Operation

a. Chlorine production

Press the power button, the "Power indicator will be lit and the pool pump will be showed on the LCD display and start. Delay 5 seconds, "Chlorine icon will be showed in LCD display and start to produce chlorine. If the system is to Timer-2, the chlorine starts and stops upon based programmed time, shown as figure 11.

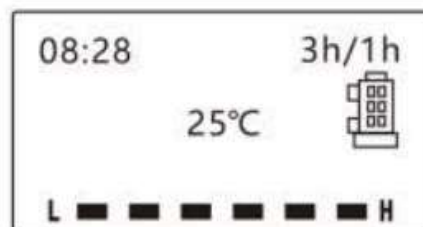

Figure 11

b. Setting the chlorine output level: 6 levels options. Press +/- button to increase or decrease chlorine output and shown on small blocks under screen. More bright blocks signify more chlorine output. Maximum is 6 blocks. Shown as figure 12

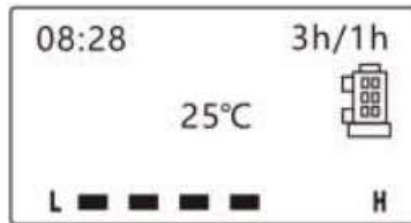

Figure 12

c. state view: press and hold restart button, original display chlorine production, now change to display controller internal temperature, operating voltage, liquid level detection, shown as figure 13. Note: the state view function is convenient for trouble shooting.

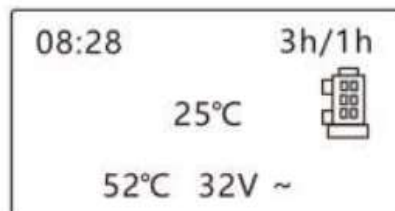

Figure 13

d. Fault reset when "ERR Code (1): E1" icon shown on LCD screen, as figure 14, check the fault code table, according to the excluded method, long press - button, Error code disappears.

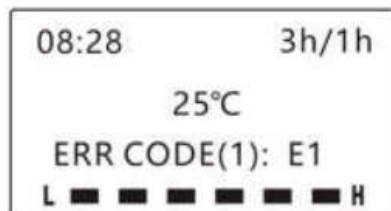

Figure 14

CHECKING CHLORINATOR OUTPUT

Four factors directly affect the chlorine production:

1. Pool salt concentration
2. Chlorine output setting
3. Chlorinator working time.
4. Pool water temperature

In order to achieve the optimal chlorine production, first check whether the pool salt concentration meets the requirements (appendix The environment and maintenance of salt chlorine generator). Secondly, set the filtration time according pool volume. Initial use salt chlorine generator, it is suggested to lower a half chlorine output for few days, regularly test the amount of chlorine every day, and correspondingly adjust chlorine output. After several debugging to determine the best settings. As general guide it is suggested adjusting the amount of chlorine production according to actual use of the swimming pool, such as increasing chlorine output in summer peak season with increasing number of swimmers and reducing chlorine output when water temperature is high and low frequency use in cold period.

Salt chlorine generator production test:

1. Start the salt chlorine generator, by observing flow water whether with white mist, if there is, means chlorine production normally. Salt chlorine generator production test.
2. Get water sample from backwater/outlet of swimming pool to detect the chlorine content and record the measured data.
3. When the cycle is filtered and the maximum chlorine production is generated, get water sample from water inlet of the pool to detect chlorine content. The result is 1PPM larger than the first sample, meaning the salt generator is normal working

THE OPERATING ENVIROMENT AND MAINTANCE OF SALT ELEKROLYSE

The operating water environment of the salt chlorine generator

1- Water chemistry condition

May the pool bring you a lot of fun, may secure your swimming, may prevent from corrosion and scale on your pool equipment, please keep regular test and check your pool's water quality. The following chart is the national and international standard of water chemistry environment for swimming pool, and the best water quality condition for Laswim salt chlorine generator working.

Chemicals	Recommended value
Free residual chlorine	1-3.0 ppm
Salt	2700-4500 ppm
pH value	7.2 – 7.8 (within this range, the chlorine requirement is minimized but the disinfectant effect is maximized)
Total basicity	75-250 ppm
Stabilizer	60-80 ppm
Calcium hardness	75-500 ppm
Total dissolved solid amount (including salt)	3500-5700 ppm. Maximum does not exceed 6000 ppm
Metal	0
Nitrates	0
Phosphate	0
Saturation index	-0.2 – 0.2 (0 is the most optimal)

2- Saturation index

The saturation index (SI) is related to the calcium and alkali amount in the pool water, it is an indicator if the water is balanced in a swimming pool. The SI is between 0~0.2 or -0.2~0, the water quality in the pool is perfectly balanced; if the IS is higher than 0.2 or lower than -0.2, the water may cause damage or corrosion to the pool and pool equipment's.

Saturation index calculation formula:

Saturation index = PH value + Calcium Hardness coefficient + total basicity ratio coefficient + temperature coefficient + total dissolved solid coefficient.

$$SI = PH + CHF + AF + TF + TDSF.$$

calcium hardness	calcium hardness coefficient	total basicity	total basicity coefficient	Celsius degrees	Fahrenheit degrees	temperature coefficient	total dissolved solid coefficient
75	1.5	75	1.9	12	53	0.3	-12.1
100	1.6	100	2.0	16	60	0.4	
125	1.7	125	2.1	19	66	0.5	
150	1.8	150	2.2	24	76	0.6	
200	1.9	200	2.3	29	84	0.7	
250	2.0	250	2.4	34	94	0.8	
300	2.1	300	2.5	39	103	0.9	
400	2.2	400	2.6				
600	2.4	600	2.8				
800	2.5	800	2.9				

3- Water environment maintenance

Weekly test

A. Free residual chlorine level. Use reliable instrument and methods to check the level of free residual chlorine in the pool. Normal range is 1-3ppm. Chlorine concentration can be increased or decreased by adjusting the chlorine output via salt chlorine generator.

Attention: chloride ion sample collecting shall be 2 at least, positioning:

- o near water surface of pool inlet as collecting point 1.
- o away from water surface of pool inlet as collecting point 2.

Comparing two samples of free residual chlorine, the higher value should be the sample near the inlets, which is produced by salt chlorine generator.

B. PH value. Normal PH value is 7.2-7.8. If the value is too high, add acid to adjust. Add alkali to adjust if it is too low.

Monthly maintenance

- A. Total basicity. Normal value ranges from 75 to 250ppm. If the value is too high, add acid to decrease the basicity, if the value is too low add baking soda.
- B. Salt content. The normal value is from 2700 to 4500ppm, add salt according to need to reach the optimal salt concentration.

Seasonal maintenance

- A. Stabilizer. the normal value is from 60 to 80ppm, could add pyrolytic acid to increase the concentration of the stabilizer.
- B. Calcium hardness. The normal value is from 75 to 500ppm, when the value is too low, calcium can be added to increase its value; when the value is too high, pool water can be released, and fresh water added to the pool will decrease the value.
- C. Electrolytic cell: due to electrolytic cell is major component to produce chlorine, regularly checking and clean electrolytic cell is very necessary.
- D. Metal. Pool water should not contain metal such as Copper, Iron, manganese, etc.

NOTE: Salt chlorine electrolytic cell has self-cleaning function, sel clean by reverse the polarity every other four hours, which prevents calcium from accumulating and keeps the electrolytic cell in optimal performance. If water hardness is high or the water chemistry is out of balance, the cell will need to be cleaned regularly

Pool water salt concentration adjustment and maintenance

1- Pool water volume calculation

Knowing the volume of the pool is the first step to add salt to the pool (m3).

Rectangular pool: Length (m) x Width (m) x Average depth (m) = water volume of the pool (m?).

Circular pool: Diameter (m) x Diameter (m) x Average depth (m) x 0.785 = water volume of the pool (m?).
Elliptic pool: Length (m) x Width (m) x Average depth (m) x 0.893 = water volume of the pool (m?).

Edge pool: Area of the pool (m²) x 0.85 = water volume of the pool (m³).

2- The type of salt that can be used.

The higher the purity of the salt, the better the LASWIM salt chlorine generator performs and lengthen its service life.



The Sodium Chloride (NaCl) in the salt should be higher than 99.6%. Dehydration treatment food grade non-iodized salt would be the best choice.

NOTE

- A. Do not use rock salt, since it may contain impurities or other compound that may shorten the lifetime of the salt chlorine generator.
- B. Do not use CaCl₂ as a source of salt, use NaCl only.
- C. Water treatment salt pallets can be used, but the time it takes to dissolve into the water may be longer.
- D. Avoid to use of anti-caking agent salt (NaCN, YPS, it is toxic and corro-sive), this type salt may result in colour change of pool surface and equipment.

3- Adding the appropriate amount of salt

Most swimming pools contains a certain amount of salt, the concentration of the salt in the water may vary depending on the water source and the sterilization chemicals in the water. A handheld NaCl measuring instrument or salinity pen can be used to test for the current salt concentration in the water. Please use the chart on the back to see how much salt needs to be added.

- A. Suggested salt concentration is around 2700-4500 ppm (between 0.27% to 0.45%), this would be the optimal water quality. 17
- B. When below 2400ppm, the salt chlorine generator would stop working, and indicate E5.
- C. When higher 4500 ppm, may corrode and damage pool equipment, the salt chlorine generator will stop working and indicate E4.

NOTE

With different measuring practices, the salt concentration will differ. The tolerance scope is +/- 500ppm (0.05%)

4- Regulated swimming pool salt concentration.

The correct way of increasing the salt concentration.

- A. Activate the swimming pool circulation pump and start the pool water circulation.
- B. Turn off the power source of LASWIM salt chlorine generator.
- C. Test and find the current salt concentration of the pool.
- D. Calculate the amount of salt needed to be added from the chart.
- E. Pour the salt along the side of the pool slowly, allowing it to dissolve evenly and quickly into the water. Do not allow the salt to pile up on the bottom of the pool, stir the water when necessary.
- F. Run the circulation pump for 24 hours for the salt to be evenly distributed through the whole pool.
- G. After 24 hours, measure the salt concentration of the pool again to see if it has reached the desired level.
- H. When the salt concentration has reached the desired value, activate the LASWIM Salt chlorine generator to produce chlorine according to your setting. Decreasing salt concentration. The only way to decrease the salt concentration is to discharge some of the water, then add fresh water to the pool and measure the concentration of the pool referring to 2.41. The weight of salt needed to maintain 3200ppm (0.32%) for each ton of water. Unit in kilograms

Decreasing salt concentration.

The only way to decrease the salt concentration is to discharge some of the water, then add fresh water to the pool and measure the concentration of the pool referring to 2.41.

The weight of salt needed to maintain 3200ppm (0.32%) for each ton of water. Unit in kilograms.

The salt concentration ppm before	0	100	200	300	400	500	600	700	800	900
The weight of salt needed to add per ton of water	3.210	3.111	3.012	2.912	2.813	2.713	2.614	2.514	2.415	2.315
The salt concentration ppm before	1000	1100	1200	1300	1400	1500	1600	1700	1800	1900
The weight of salt needed to add per ton of water	2.216	2.116	2.017	1.917	1.817	1.718	1.618	1.518	1.419	1.319
The salt concentration ppm before	2000	2100	2200	2300	2400	2500	2600	2700	2800	2900
The weight of salt needed to add per ton of water	1.219	1.119	1.020	0.920	0.820	0.720	0.620	0.520	0.420	0.320
The salt concentration ppm before	3000	3100	3200	3400	3600+					
The weight of salt needed to add per ton of water	0.220	0.121	Best	OK	Excess					

Note:

- This diagram is used as a reference to calculate the amount of salt to add to water.
- Calculate the amount of salt needed to add to the pool according to 2.1. for example, for 153 square cube (153 ton) of water, the original salt concentration is 400PPM, to reach 3200 PPM check the diagram. The diagram states that for each ton of water at 400PPM 2.813kg salt needs to be added, therefore for 153 ton of water the amount of salt needed is $2.813 * 153 = 430\text{kg}$.
- The readings of different measuring instruments are different, set 3200ppm as the optimal value. The actual salt added to the water should be precise to each kilogram. The salt concentration of the water needs to be between 2700-4500 PPM for the optimal working environment of the salt chlorine generator.

The stabilizer needed for each ton of water to be kept at 75ppm (0.0075%).
unit: kg

The concentration of stabilizer before ppm	0	5	10	15	20	25	30	35	40	45
The weight of stabilizer	0.075	0.070	0.065	0.065	0.055	0.050	0.045	0.040	0.035	0.030

needed to be added to each ton of water										
The concentration of stabilizer before ppm	50	55	60	65	70	75	80	80+		
The weight of stabilizer needed to be added to each ton of water	0.025	0.020	0.015	0.010	0.005	Best	OK	Excess		

Note:

A. This chart is used for referencing and calculating the amount of stabilizer to add to the pool. The optimal value of the stabilizer should be around 60-80 ppm, and 75ppm should be the standard.

B. According to 2.1 to calculate the amount of stabilizer needed to add in pool. For example, for a pool of 153 m, the initial stabilizer concentration is 35ppm, to reach 75 ppm, the weight of the stabilizer needed to add = $0.040 \times 153 = 6.12\text{kg}$.

MAINTENANCE INSTRUCTIONS

- Maintenance should be carried out at the recommended time and frequency as stated in the manual.

Maintenance of the water treatment

Maintenance has to be carried out by a person knowledgeable off swimming pool technology.

Make sure to take the necessary safety precautions before starting the maintenance such as:

- Turn off the power before starting the maintenance
- Always wear protective gloves and safety goggles when working on the installation.
- Keep the installation and chemicals out of the reach of children

Maintenance of the pH dosing peristaltic pump

The pump peristaltic tube has to be greased regularly with silicone grease. Verify that the tube feels greasy each 2 months.

The pump peristaltic tube has a lifetime of 500/600 operating hours and must be replaced annually.

The inlet and dosing pipelines must be replaced every two years.

As part of the maintenance, verify the integrity of the suction foot and injection nozzle. Replace the rubber seal of the injection nozzle yearly.

Maintenance of the RX – Chlorine dosing peristaltic pump

RX – Chlorine dosing peristaltic pump requires The same maintenance as the pH pump. For RX, special attention needs to be taken for maintaining the RX injection nipples, as blockage of the injection nipple may cause the peristaltic tubing to start leaking (due to pressure build-up)

Maintenance of the Chlorine injection nipple

Anti calc

The chlorine injection nipple can leak due to blockage by saling / Calcium carbonate crystals coming from the chlorine (blockage before the one-way rubber in the chlorine injector), or from high water hardness (Calcium content) of the swimming pool water.

This can be avoided by adding anti-scaling to the chlorine.

How to prevent scaling of injection nipples?

1. Use anti-scaling chemicals:
 - Employ chlorine-containing anti-scaling agents.
 - Add anti-scaling agents to the chlorine container.
2. To reduce the incidence of Calcium-rich swimming pool water coming into contact with the chlorine in the injection nipple (zone after the one-way rubber), attach a 5-10cm long tube (use part of the peristaltic aspiration tube) to the injection nipple.
3. Complete the chemical cleaning procedure yearly (more if required), or replace the injection nipple yearly.



Removal of Scale Build-Up in Liquid Chlorine Peristaltic Pump Injection Nipples

Scale build-up, a result of sodium and/or calcium carbonate crystal formation within liquid chlorine, poses significant challenges. These crystals develop

- 1 Due to precipitation / coagulation of suspended solids in freshly produced liquid chlorine (ref 1,2)
- 2 By reaction of Sodium Carbonate in the Liquid Chlorine and Calcium / Magnesium in the pool water.



Calcium- and or/magnesium carbonate crystals

The accumulation of scale within the injection nipple obstructs its function, potentially disrupting the flow. This obstruction can result in various undesirable outcomes:

- Decreased or halted chlorine flow
- Leakage from the injection nipple itself
- Swelling and leakage of peristaltic tubes

Such issues not only jeopardize operational efficiency but also present safety hazards. Additionally, prolonged scale presence can induce corrosion in the equipment.



How to de-scale the injection nipples?

First, it's important to understand the construction of the injection system.



<- injection tube seal

← Rubber check valve preventing swimming pool water to flow to the liquid chlorine container



The blockage of the check valve by scaling crystals can lead to a reduction or complete halt in chlorine flow, as well as leakage at the seal of the injection tube and swelling and breakage of the peristaltic tube.

Method 1: Physical Removal of Scaling

Using a small screwdriver, carefully unblock the rubber check valve. This action may temporarily restore flow.

Ensure the screwdriver is of an ideal (minimal) length of 5.0 cm. Gently push and turn the screwdriver until reaching the rubber one-way valve to avoid damaging it. Always wear safety goggles and gloves during this procedure.



Method 2: Chemical Descaling

The scaling can react with vinegar to produce CO₂ gas. Caution: Liquid chlorine will react with vinegar to produce gaseous and highly dangerous (toxic and corrosive) chlorine gas. It is absolutely essential to flush the injection nipple thoroughly with water before and after the vinegar treatment.



Always wear safety goggles and gloves during this procedure.

Method 2 : Chemical descaling

Step 1: Flush the chlorine injection circuit with a minimum of 1.5 liters of water.

- Unscrew the injection nipple from the measurement and injection tube, ensuring that you can catch the chlorine/water mixture that you are about to pump through the chlorine injection system.
- Replace the chlorine container with one containing plenty of water. Using warm water (50°C) will already significantly reduce scaling issues.
- Switch off the pH pump, set the Chlorine injection setpoint to 1000 mV, and begin pumping water through the system.



Step 2: Flush the injection lines and nipple with 500ml of vinegar.

- Place both the suction foot and injection nipple in 500ml of vinegar, and circulate the vinegar for 8 hours.



Step 3: Flush the chlorine injection circuit with a minimum of 1.5 liters of water.

This step is a repetition of Step 1 to ensure no residual acid remains in the system. Remember: Liquid chlorine and acid react to form poisonous chlorine gas.



After completing these steps, screw the injection nipple back into position, pressure test, and restart chlorine addition.

Don't forget to set the redox setpoint to its original value and switch on the acid pump.

Ref 1

<https://powellsolutions.com/wp-content/uploads/2021/07/810-General-Info-Handbook.pdf>

Sodium Carbonate is part of sodium hypochlorite by nature of the process, but if the sodium hypochlorite has low suspended solids, it does not influence the use of sodium hypochlorite and sometimes will make the product more stable. Sodium carbonate comes from some sodium hydroxide depending on the manufacturing process used. It forms when air comes in contact with sodium hydroxide, and is part of the manufacturing process.

Sodium carbonate concentration may be a problem if the solution already contains a significant amount of other suspended solids. Then the sodium carbonate will help to collect the suspended solids into large enough particles to drop from the solution and coat the bottom of the tank, pumps, and

pipings with insoluble compounds. Over time, this will cause a system to need servicing because of plugged pumps, piping and instrumentation.

Ref 2

<https://powellsolutions.com/wp-content/uploads/2021/07/810-General-Info-Handbook.pdf>

Suspended solids in the product at the time of delivery are typically not visible and don't change the color an appreciable amount. During storage and pumping, these suspended solids will become larger and drop out of solution into the storage tanks and onto the pumps, piping, valves, and instrumentation. Over time, it can make the feed systems non-functional, which causes costly maintenance to remove them.

Maintenance of salt chlorine generator.

1- Maintenance of electrolytic cell

To ensure the LASWIM salt chlorine generator work in best working performance, cel cleans by reverse the polarity every four hours, check the electrolytic cell every 3 months or after cleaning the filter. A. Before removing the electrolytic cell, first power off the salt chlorine generator 5-10 minutes, then close inlet/outlet valve. B. After removing the electrolytic tank, check the cell wall for flaky sediment, debris, light colour crust or other dirty.

WINTERIZING AND SPRING START-UP INSTRUCTIONS

Winterizing the system

Winterize the units containing electronics, unit in a dry and warm (15 – 25 ° C) environment.

Winterize the pH and RX probes in a special winterizing solution for probes (which is a KCl-water mixture). Make sure the probes are always kept wet.

To ensure thorough cleaning, it is essential to flush all tubes of the peristaltic pumps with water. This process contributes to maintaining optimal hygiene standards and extends the lifespan of the equipment.

Flushing the tubes of the peristaltic pumps requires careful attention. We begin by circulating 250 ml of clean water through the pump. This ensures that any remaining residues or contaminants are flushed away, preparing the pumps for further cleaning and use. For the Chlorine peristaltic pump, use the maintenance method described above under “descaling”

A next step in this process is removing the white peristaltic tubing from the roller assembly. This is an important step to ensure that the tubing can be thoroughly cleaned and inspected. By carefully removing the tubing, we can detect any blockages or damages and take corrective measures if necessary.

Do not insert the white peristaltic tubing into the pump until spring start-up, as leaving the tube into the peristaltic chamber may squeeze it indefinitely.

Spring start-up

Recalibrate the pH and RX probes.

Verify for leaks. Verify and adjust the salt level.

Insert and grease – with silicon grease – the white peristaltic tube and rollers.

Correct pH, if needed temporarily dose pH+ (manually or automatic).

At correct pH (7.2 - 7.6): make sure pH- is used and set in the app. Start up the RX pump. After reaching 650-700mV, verify the free chlorine level using a high quality measurement and adjust the redox setpoint as described above.

TROUBLESHOOTING

Troubleshooting Wi-Fi / app related problems

For Wi-Fi equipment, it is possible to share the app with your supplier or the manufacturer. This is explained in the Problem-solving section of the Wifipool app and simple device manual.

Setting up a Teams meeting via your telephone and sharing the screen will also allow your supplier / manufacturer to see your telephone screen.

Deviation of the pH measurement compared with another method.

We have a very specific order that we recommend in case of doubt pH measurement.

This is the result of many years of experience.

When working with probes, one must accept the following as true:

- In principle, a calibrated probe measures correctly, more correctly than a color method.
- A probe that calibrates itself works
- The color method works correctly, only if the alkalinity of the water is correct.
- A difference of 0.2 between two methods is normal, a difference of 0.5 is not acceptable.
- A simple measurement of droplets does not give reliable results

Here are the steps to follow in case of doubt about the pH:

In case of opposite pH measurement (one method gives an acidic result, the other method gives a basic result):

Take a glass of water and add 2 tablespoons of vinegar. Both methods must measure an acidic pH. If the probe gives a pH > 7: add 10 spoonful of vinegar and see if the pH rises or falls. If the pH rises: contact the sensor supplier

After this verification:

Always take samples in the pool just before the skimmer, so that the sample corresponds to the water passing by the electrodes.

1. Recalibrate and remeasure pH with probe. If in doubt:
2. Check and adjust the alkalinity of your water between 80 and 120 and remeasure the pH with your color method. If doubt remains

3. Renew the pills/liquids of your measurement tool and remeasure the pH with your color method. If doubt remains :
4. Buy a new calibration solution and measure pH with probe. If doubt remains
5. Buy a certified pH 7.4 solution and measure pH with a probe. If the pH of the probe is between 7.2 and 7.6 accept the probe. If the measured pH is 7.0-7.1: check the pH at 7.6. If the pH of the probe is 7.7-7.8: control the pH to 7.2. If the pH is lower than 7.0 or higher than 7.8: contact your supplier (Pool Duo supplier as well as the supplier of the alternative method).

Deviation of the Redox measurement compared with another method.

A deviating RX value is not so bad if the probe is sensitive to changes and the redox increases when more chlorine is added to the pool.

You can test this by mixing 5 drops of liquid chlorine in a bucket of water and measuring the redox before and after adding the chlorine. Due to the 5 drops, the Redox must rise significantly.

A deviating redox can be caused by a deviating pH and/or by "contaminants" in the swimming pool such as flocculant, anti-algae, wall cleaner, etc.

A deviating redox is not so bad. You proceed as follows: measure the free chlorine content in the pool using a color method (before measuring the chlorine content, the pH and hey cyanuric acid content must be within specifications). Add chlorine to the pool until the chlorine level is 1-1.5ppm. The redox that you then read is the redox that you must set as the setpoint.

If you still have doubts about the redox value you have read, you can proceed as follows:

- Change calibration fluid and recalibrate the device.
- If you still have doubts about the redox value read:
 - Exchange redox probe and recalibrate.

Troubleshooting for the peristaltic pump

For any problems with the app or the Wifipool device, it is recommended to consult the Wifipool App and Simple device manual. This guide provides detailed instructions for identifying and resolving common errors.

PROBLEM	CAUSE	SOLUTION
Acid pump does not dispense	No electrical power present	Verify electrical power Startup acid pump via manual control.
Acid pump does not dispense	Switch under the dosing pump is set to "0"	Set switch to "1"
	Settings of pH control are wrong : pH+ while pH- is dosed (or vice versa)	Verify settings
	There is a level detector attached that gives a wrong contact	Delecte Level Detector from pH dosing requirements.
	A flow switch is connected and it indicates that there is no flow	Delecte Flow from pH dosing requirements.
Acid pump continues to dose	Setpoint not yet reached	No Action Required
	Wrong parameter set : pH+ while pH- is being dosed (or vice versa)	Corrects parameter.
	Smart plug error	Reset smart plug (delete from app , hard reset (7xin-out) and re-install.
	Relay on PCB Stuck	Contact supplier.
Acid pump only dispenses occasionally	Acid pump is on proportional dosing or in duty cycle mode	No Action Required
Acid pump does not pump.	A flow switch is connected and it indicates that there is no flow	Verify flow and flow switch (Delecte Flow from pH dosing requirements)
	There are level detectors attached that give a wrong contact	Disconnect Level Detectors. (Delecte level detector from pH dosing requirements)
Acid pump does not suck up liquid	Barrel is empty or suction foot hangs above liquid level	Replace acid or chlorine container; Lower suction foot.
	Suction foot is clogged	Replace suction foot ZWMX2205
	Peristaltic tube is leaking	Replace peristaltic tubing ZWMX2231 or AWMX2232 Ensure dosing tube is greased regularly

	Injection nozzle is clogged	Replace injection nozzle ZWMX2220
Liquid (acid) in dosing compartment of acid pump	Santoprene or Viton tube leak	Verify if dosing nipple is clogged, and replace dosing hose. Ensure dosing tube is greased regularly
Dosing tube in pH forms a bladder	Supply of acid in injection nipple curdled by dirt / calcification	Immediately stop dispensing acid and clean/replace the nipple.
Calibration failed	Calibration solution obsolete or dirty	Replace calibration solution
	Probe not yet in balance	Repeat calibration
	Broken probe	Replace probe
	Probe has been standing dry	Replace probe
Device gives alarm: pH too high	pH > 8.5	Verify pH with color method. Correct pH manually or switch off the alarm function once and let the dispenser reduce the pH.
	pH > 8.5	Drum mistake : you are using pH+ instead of pH-
	Electrode broken	Replace electrode
	Acid pump does not suck up liquid	See above
Device goes into alarm: pH too low	pH<5.5	Drum or setting error : setting is pH+ and drum is pH-
	pH<5.5	Verify pH with color method. Correct pH manually or switch off the alarm function once and let the dispenser reduce the pH. Use pH+ once and set device setting to pH+
	Electrode broken	Replace electrode
	Overdosing	Use the duty cycle function to slow down dosing.
pH always 7, also in calibration solutions pH 4 and pH 9.	pH probe broken	Replace probe
Scale Build-Up in Liquid Chlorine Peristaltic Pump Injection Nipples	Failure to Use Anti-Scaling Equipment: Neglecting to employ chlorine-containing anti-scaling agents. Omitting the addition of anti-scaling agents to the chlorine container.	You can find the solution in chapter: MAINTENANCE INSTRUCTIONS Maintenance of the Chlorine injection nipple

	<p>Neglecting the Chemical Cleaning Procedure: Failure to complete the chemical cleaning procedure yearly (or more frequently if necessary). Ignoring the replacement of the injection nipple on an annual basis.</p>	
--	---	--

APP PROBLEMS

Issue	Possible cause and solution
<p>1 The app cannot find my device.</p>	<p>If something goes wrong during the pairing process (e.g. loss of WIFI), it may be necessary to reset a plug or measurement box. Plug your plug or measurement box into the mains for 30 seconds, then: 1. Plug in your plug or USB briefly (1-2 sec) and then unplug your plug/USB for 2-4 seconds. 2. Repeat this step a second, third, fourth, fifth, and sixth time 3. Insert your plug or USB briefly (1-2 sec) and let it in on the 7th time</p>
<p>2 I can't pair my device.</p>	<p>There are two possible causes: 2a Your Wi-Fi network is not strong and stable. Bring the Wi-Fi devices into your home, close to the Wi-Fi source. Make the connection between the devices and the phone and then bring the devices to the pool house 2b Your phone/Android version is not compatible with the Wifipool app. In this case, you can ask a friend to pair the devices with their phone. Once linked, he/she adds you as a user and promotes you to owners. Also let us know (info@beniferro.eu) what phone you have and what IOS or Android version it has so we can customize the app.</p>
<p>3 My device does not connect to WiFi</p>	<p>If your device does not connect to your Wi-Fi and you've made sure the Wi-Fi credentials are correct, it can be caused by using special chars or white spaces in your SSID or Password of your Wi-Fi. Remove them and try again. Other reason can be using an SSID longer than the allowed 32 characters.</p>

SALT ELECTROLYZER

Error code	Cause	Remark	Solution
E1	Indicates that aircooling fin temperature is too high	the maximum temperature is 65°C. the fault display must be cleared manually.	First check whether there is E6 error code, if yes, please ensure that the temperature sensor is connected, if connected well please change the sensor. If E6 error codes not present, please check the hardware circuit
E2	Indicates the water temperature exceeds the normal temperature range	Normal working temperature range: 10~45°C	First check whether there is E7 error code, if yes, please ensure that the temperature sensor is connected, if connected well please change the sensor. If E7 error codes not present, please make sure the operating water temperature is within the normal range.
E3	Indicates no water	Normal operation should be with sufficient water flow through the cell.	First ensure the water level sensor has been connected, if already connected, then check whether it is lack of water or with air, if there is water, then clean the water level probe.
E5	Means the salt concentration is low	Normal working salt concentration 2700-4500ppm	First use a salimeter to check the salt concentration in the pool. When the salt concentration is below 2700 ppm, add right amount salt into the pool. When pool salt concentration reaches to the normal working range, the error code will be cleared automatically, and the machine will start to work normally.
E6	Indicates the temperature sensor inside the control box has malfunctioned	the fault display must be cleared manually	First check if the corresponding temperature sensor is connected, if it is connected, please change the sensor.
E7	Indicates the water temperature sensor has malfunctioned	the fault display must be cleared manually	First check if the corresponding temperature sensor is connected, if it is connected, please change the sensor.
E8	Indicates the system power	the fault display must be cleared manually	Please change the hardware of the power supply.

	input is too high or too low		
E9	Indicates controller current output is too high	the fault display must be cleared manually	Please contact the supplier to replace or examine the control box.
EA	Indicates that the electrode has malfunctioned	the fault display must be cleared manually	First check the electrode is connected, if connected well please change the electrode.
EB	Indicates the system memory chip has malfunctioned	the fault display must be cleared manually	Contact supplier to examine or replace the memory chip.
EC	Indicates the system detects a circuit fault	the fault display must be cleared manually	Turn the power off and reboot, if not report failure, can start normally. If the fault occurs repeatedly, please contact the supplier to examine or replace the control box.

Power switch on, if "power" indicator of control panel is not on, please check if there is AC220V power input at the electronic board input connection. If there is power input, please check if the fuse on the circuit board has burned out. If everything is normal, may the electronic board have been damaged, please contact the supplier.

WIRING DIAGRAM

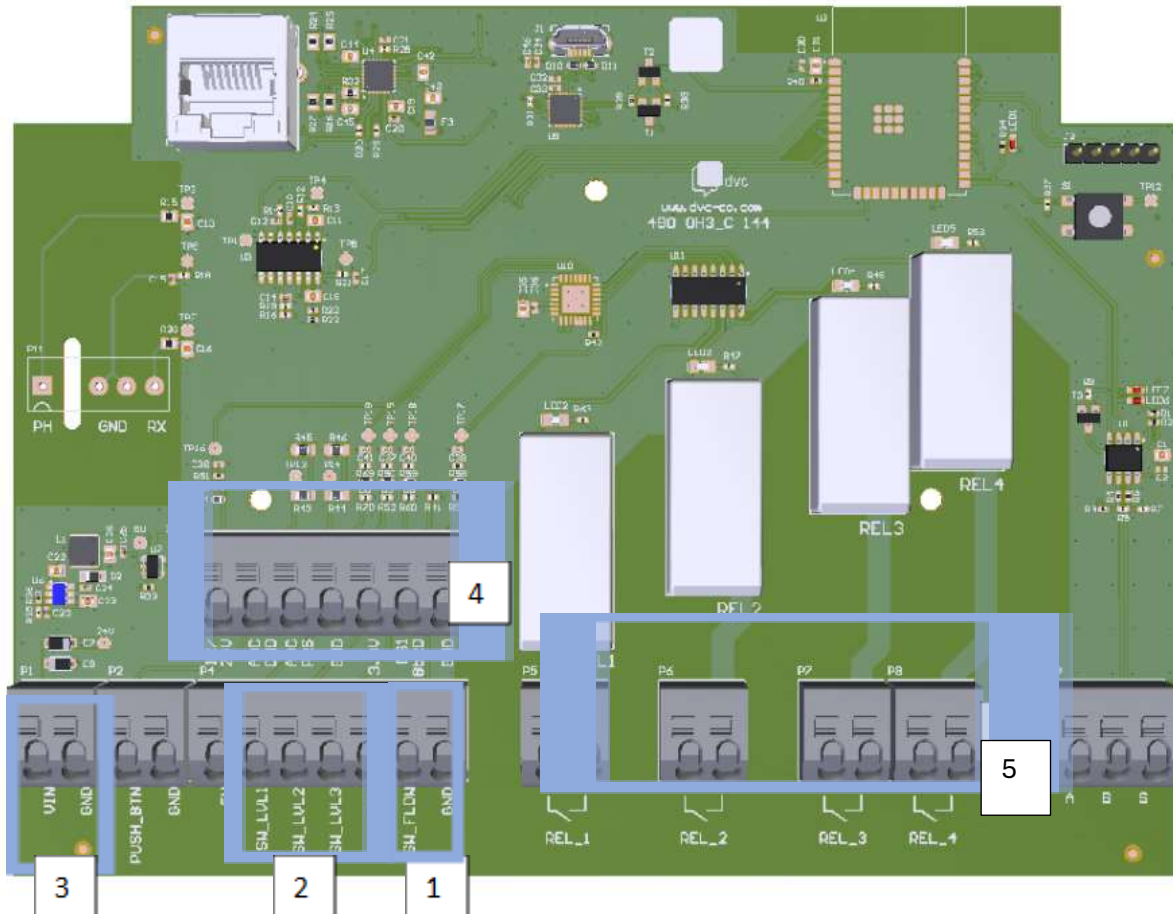

1	Flow switch
2	Level switches
3	Power supply
4	Temperature
5	Relays

LET OP: Er zijn printplaten van 12V (zoals dit voorbeeld) maar ook van 24V. Een 12V adapter werkt niet op een 24V plaat en omgekeerd!

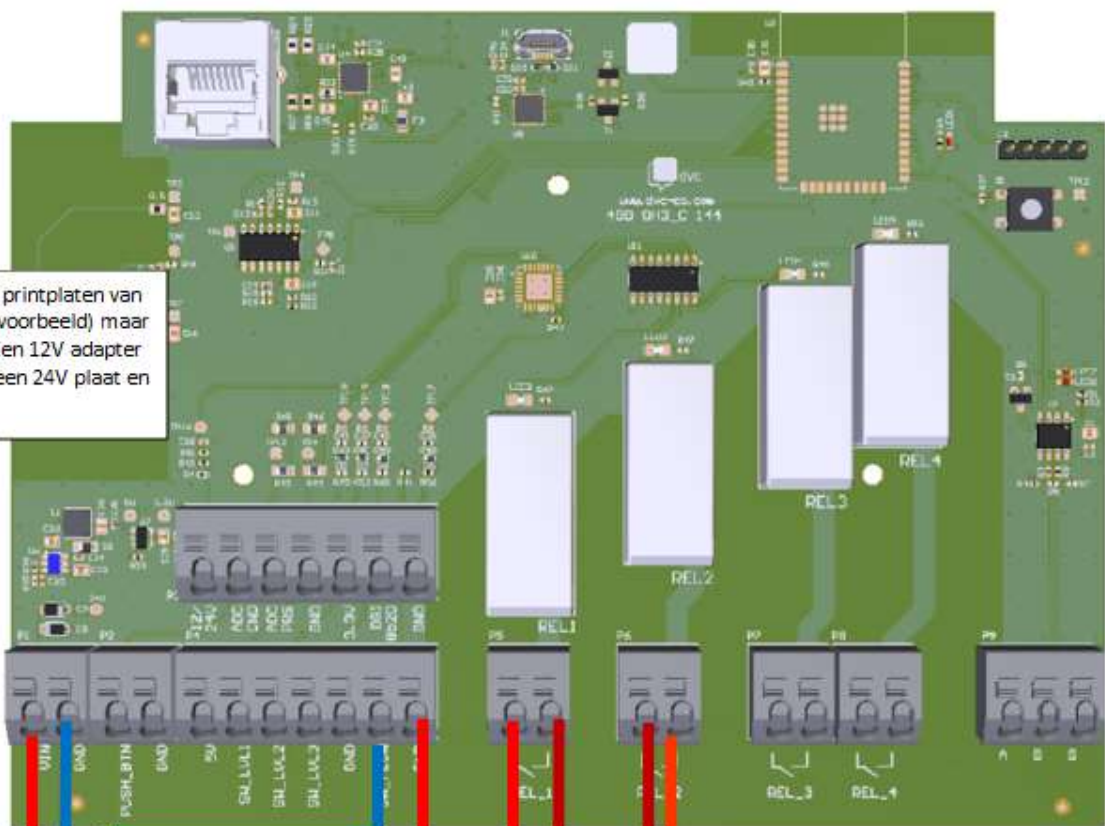

Voeding
230- 12v dc

Flow
switch

RX pomp

pH pomp

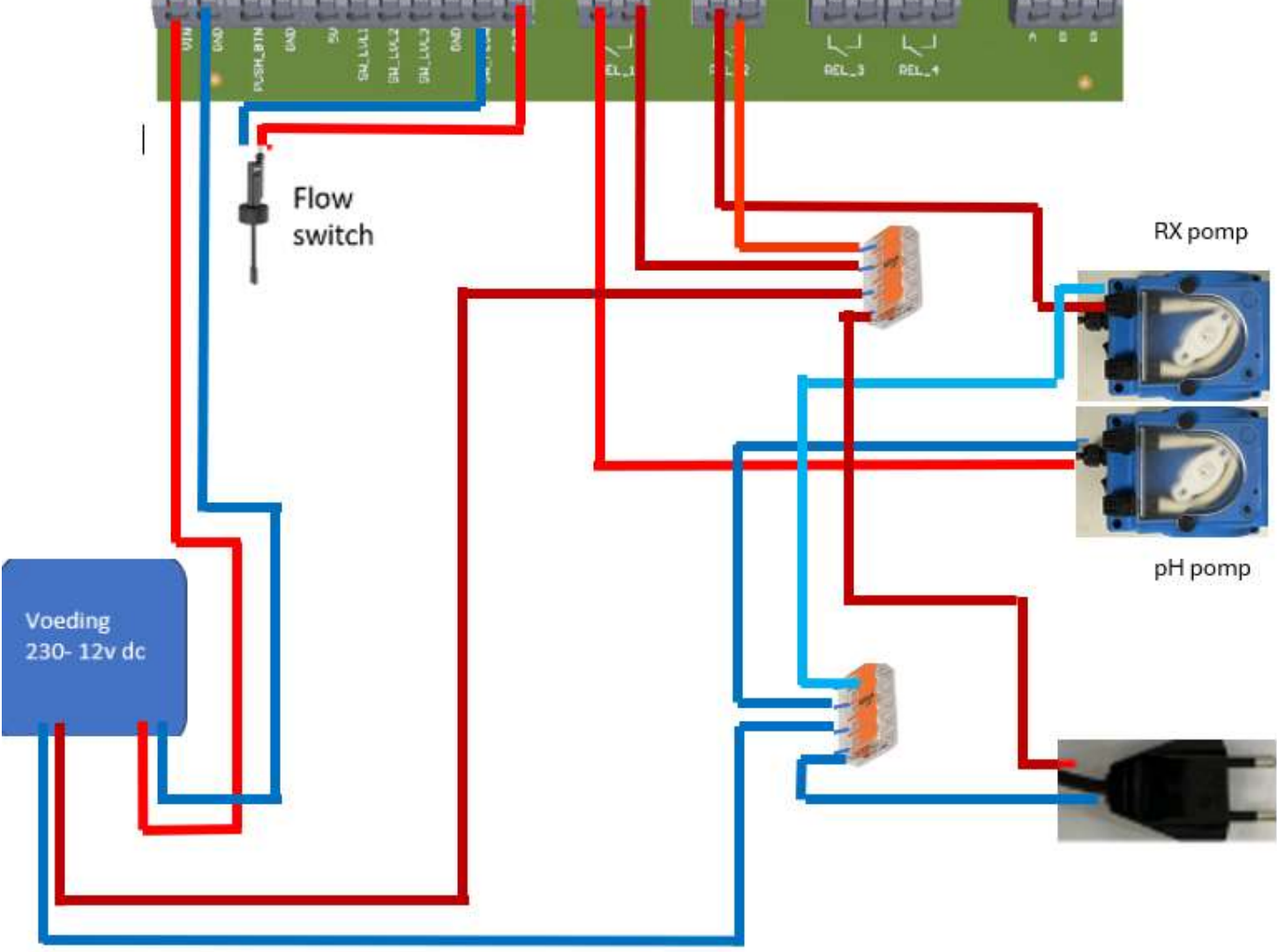

Connecting level switches

