

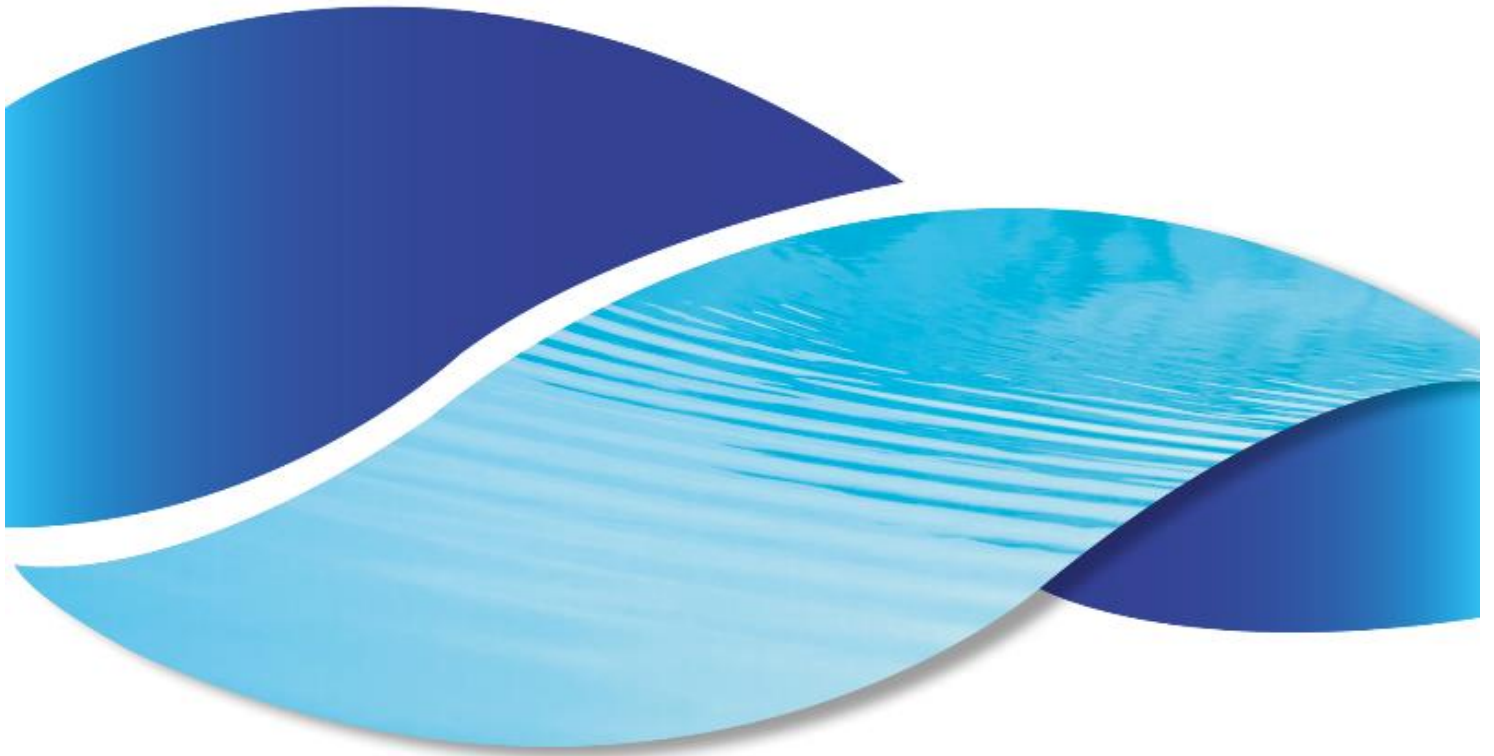

BENIFERRO.eu
plug & play products



Wifipool App and Simple Devices – full manual



Contents

Introduction

1. The Wifipool app.....
 - 1.1. Introduction
 - 1.2. Installation of the app
 - 1.3. Changing your password, profile and privacy settings
 - 1.4. 1.4 Log out
- 2 Pairing.....
 - 2.1 What is pairing.....
 - 2.2 Problems with pairing.....
 - 2.3 Before pairing.....
 - 2.4 Pairing via ethernet connection.....
 - 2.5 Pairing via website.....
 - 2.6 Pairing via smartphone for IOS.....
 - 2.7 Pairing via smartphone of for Android.....
 - 2.8 Pairing trouble shooting.....
- 3 Using the Wifipool app.....
 - 3.1 Pool Settings
 - 3.1.1 Pool
 - 3.1.2 Control plugs and measurements
 - 3.1.3 Unpair
 - 3.1.4 Rename
 - 3.1.5 Calibration
 - 3.2 Automation & Setting
 - 3.2.1 Existing automation module
 - 3.2.2 Manual automation entry
 - 3.3 Snippets
 - 3.4 Wheel settings
 - 3.4.1 Wheel editing
 - 3.4.2 Icon selection
 - 3.4.3 Fail safe
 - 3.5 Action devices : Plugs and switches
 - 3.5.1 Plugs
 - 3.5.2 Switches
 - 3.6 Measurement devices
 - 3.6.1 pH
 - 3.6.2 RX
 - 3.6.3 Temp
 - 3.6.4 Control devices
 - 3.6.5 0-10V

3.6.6 Combined measurement and action devices

3.6.6.1 0-10V

3.6.6.2 All-in Gen 2 – 2024

4 Problem Solving

5 Appendices

5.1 Appendix 1 : automation barcodes

5.2 Appendix 2 : automation details

5.3 Technical specifications

Introduction:

The "Wifipool" app can be used to monitor and control your pool using the Wifipool Connect Pro Measurement and Control Box, smart plugs, and various sensors such as pH, Redox, and Temperature, along with associated accessories such as pH probes and temperature sensors.

To install and use the measurement and control box, you need to follow a series of steps:

- 1 Installing the Wifipool App
- 2 Connecting the Measurement and Control Box to the Wi-Fi Network and Phone
- 3 pH and RX calibration (if applicable) & automation



After completing these three steps, your device will be operational.

This manual describes the installation and use of the Wifipool app (step 1) and explains basic hardware functions (step 2)

The detailed specific operation of Wifipool filter pumps, water treatment modules, calibration and heating equipment are explained in the device manuals.

With Wifipool, it is possible to truly use one app for the control of your swimming pool.

We hope the product will contribute to a perfect pool control experience and great swimming pool pleasure

The Wifipool Team

1. The Wifipool app.

1.1.Introduction

The "Wifipool" app can be used to control your pool using the Wi-Fi pool measuring devices for pH and Redox, in combination with the Wi-Fi pool control devices such as smart plugs / smart switches, peristaltic pumps, and salt electrolysis.

The main page of the app features a wheel interface, displaying measurement values such as temperature, pH, etc. Swiping left or right on the wheel enables users to switch between multiple pools or create additional ones. **1** Tapping in the middle of the wheel or on the arrows allows users to toggle between different parameters of the selected pool, such as pH value, temperature, etc. **2** Tapping on the pool name redirects users to the pool's settings menu. **3** Selecting 'Edit Wheel' permits users to modify the content and order of the values displayed in the wheel.

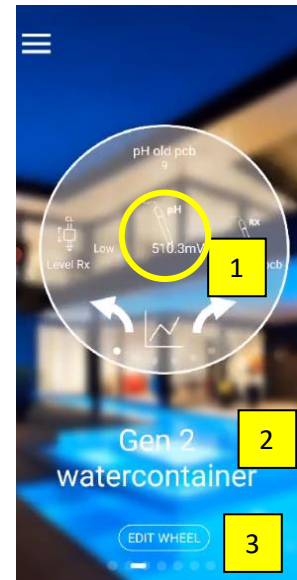

On the initial screen, **1** users can observe the status of your current value, whether it is on or off. Additionally, **2** there is a button for accessing statistics. Tapping the statistics button reveals how the current values are changing over time. **3** Two arrows, pointing left and right, facilitate navigation through the various pages. These pages include sections for pH, Rx, pH flow, and Rx flow.

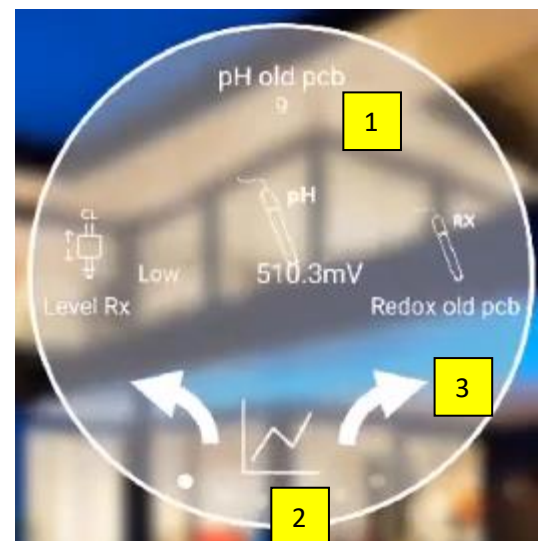

In addition to the Wifipool app, you need measuring boxes with accessories (probes, sensors etc.) to measure and display the pH, Redox, temperature etc. and smart plugs or other Wi-Fi pool control devices to turn your equipment on or off.



Before being able to use the app, you will need to install it. Then, you'll need to pair the Wifipool devices with your home Wi-Fi network and your phone. Finally, you will need to install the automations.

There are two versions of the Wifipool device: Gen 1 and, as of 2024, Gen 2. Gen 2 combines measuring and control devices on one PCB. Gen 1 operates via Wifi,, Gen 2 devices operate via Wifi and ethernet.





To connect the device, you first need to pair it to your phone and home network. Pairing via a ethernet cable is significantly more rapid and easier than pairing over Wifi.



1.2. Installation of the Wifipool application

1.2.1 Download the app

Android

1.  Go to the Google Play Store on your mobile device.
2.  Search for Wifipool
3. Click Download
4. Open the app and tab on the “Create one!” link. This will enable you to create an account. If you already have an account, you are not required to do so again. Continue following the instructions.

IOS (Apple)

1.  Go to the App Store on your mobile device.
2.  Search for Wifipool
3. Click Get
3. Open the app and tab on the “Create one!” link. This will enable you to create an account. If you already have an account, you are not required to do so again. Continue following the instructions.

1.2.2 Creating Wifipool Account

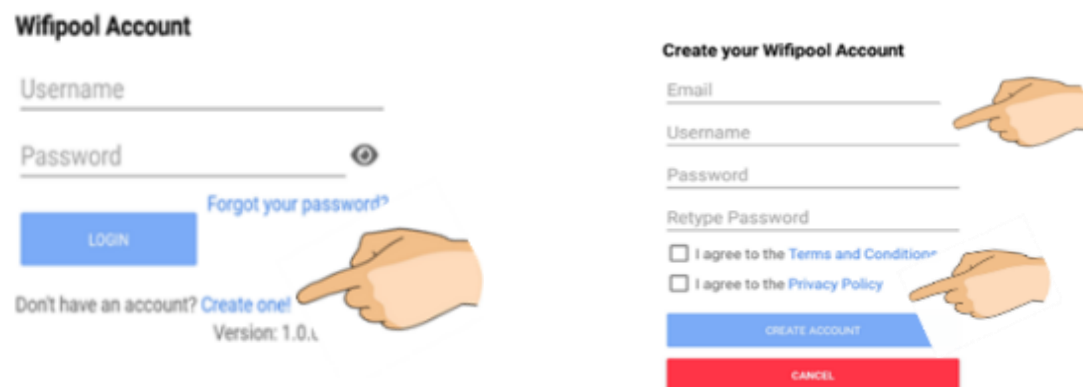

Wifipool Account

Username _____

Password _____ 

[Forgot your password?](#)

LOGIN

Don't have an account? [Create one!](#)

Version: 1.0.1

Create your Wifipool Account

Email _____

Username _____

Password _____

Retype Password _____

I agree to the [Terms and Condition](#)

I agree to the [Privacy Policy](#)

CREATE ACCOUNT

CANCEL

4. Enter your personal details and consent to the terms and conditions as well as the Privacy Policy to create a Wifipool account.
5. Press create account. The app will then send a verification email to your email address.
6. Proceed to your personal email account to confirm your email address. Check your 'spam' folder, as the email may end up there. If you haven't received an email, there might be a typing error in the email address or password. Consider trying to create the account again

1.2.3 Checking Wifipool version

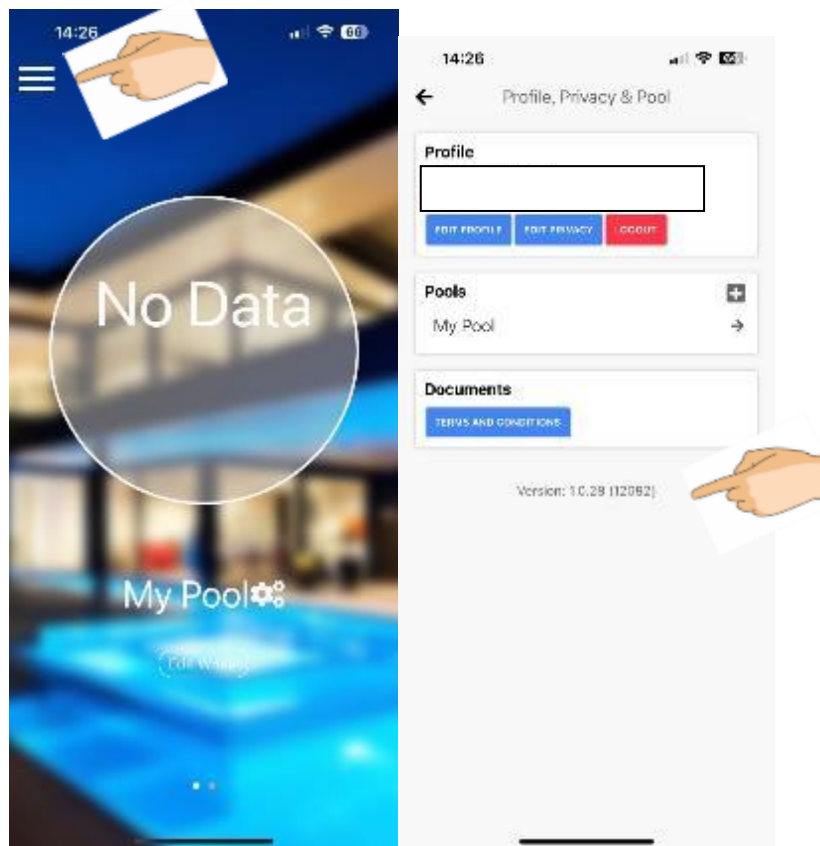

1. Always ensure you have the latest version of the app.
2. To do so, press \equiv in the top right corner of your screen.
3. This action will open the Profile, Privacy & Pool settings.
4. At the bottom of this screen, you will find the current version of the app.

Please note: The version displayed in the photo may not be the latest version of the app. Do not be alarmed if your version happens to be newer.

1.3.Changing your password, profile and privacy settings

Edit Profile and password

1. Click on the top left corner to go to the open the navigation bar and tab "Edit profile, privacy, logout".

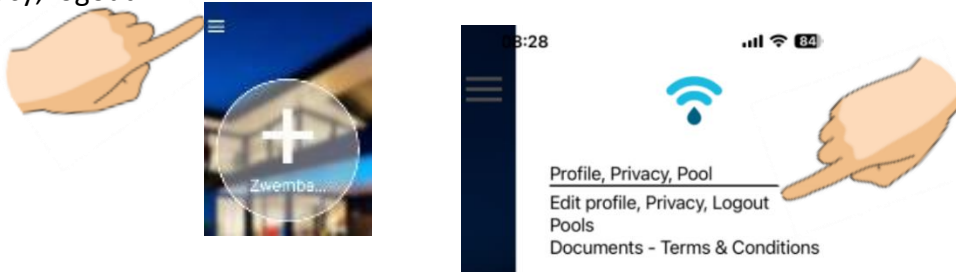

2. Click "Edit Profile"

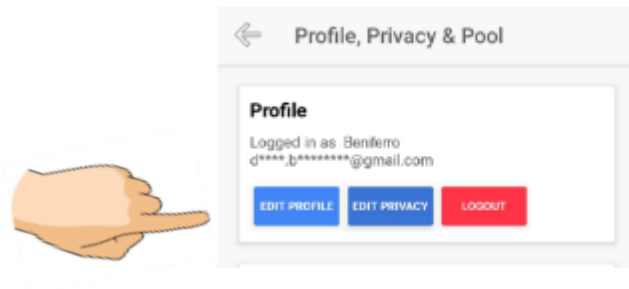

- 3 Change your personal information

- 4 Scroll down and click "Update" to confirm your changes

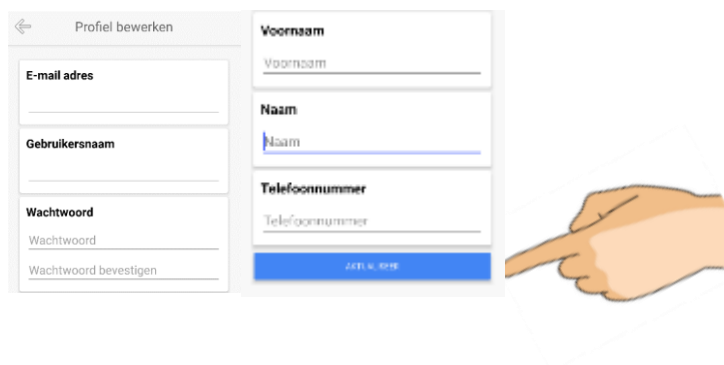

Privacy settings

1. Click on the top left corner to go to the open the navigation bar and tab “Edit profile, privacy, logout”.
2. Click "Edit Privacy"

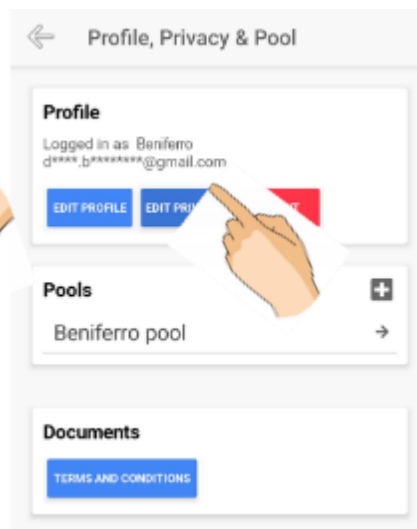
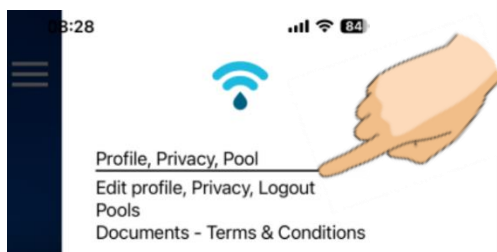
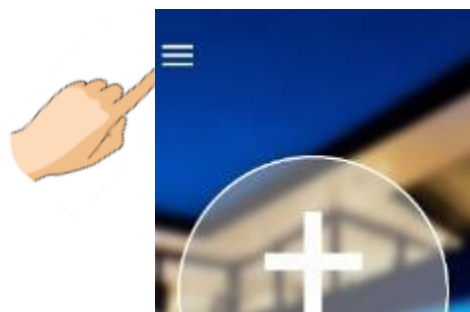

3. You can adjust your privacy settings by toggling the checkboxes.
4. Scroll down and click "Update" to confirm your changes



Please note: The above privacy settings may not display the complete list. They might not reflect the latest version. For the most up-to-date privacy settings, refer to the settings available on your phone.

1.4. Log out

1. Click on the top left corner to go to Profile, Privacy and Pool
2. Click "logout"

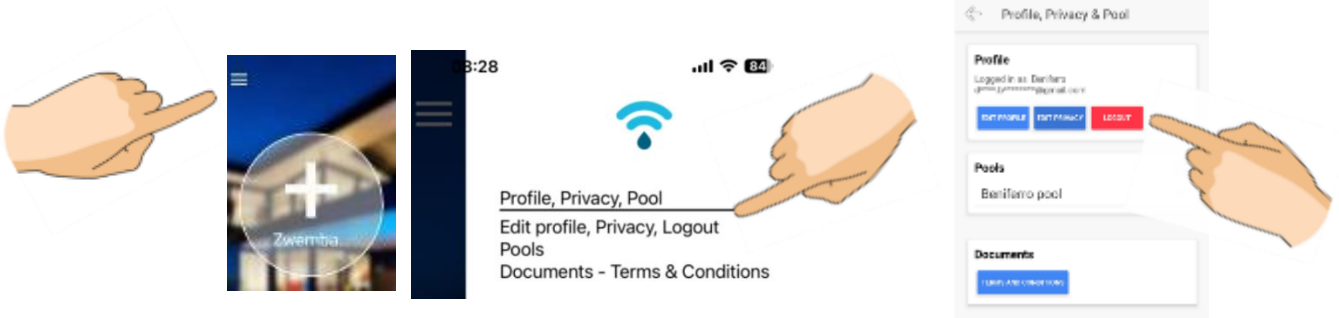

2 Pairing

2.1. What is pairing ?

Each Wifipool device emit a Wi-Fi signal. During the pairing process, we establish a connection between the Wi-Fi signal emitted by the Wifipool devices and the Wifipool cloud through our home network. We use our phone and ethernet connection (GEN2 only) to facilitate this connection.

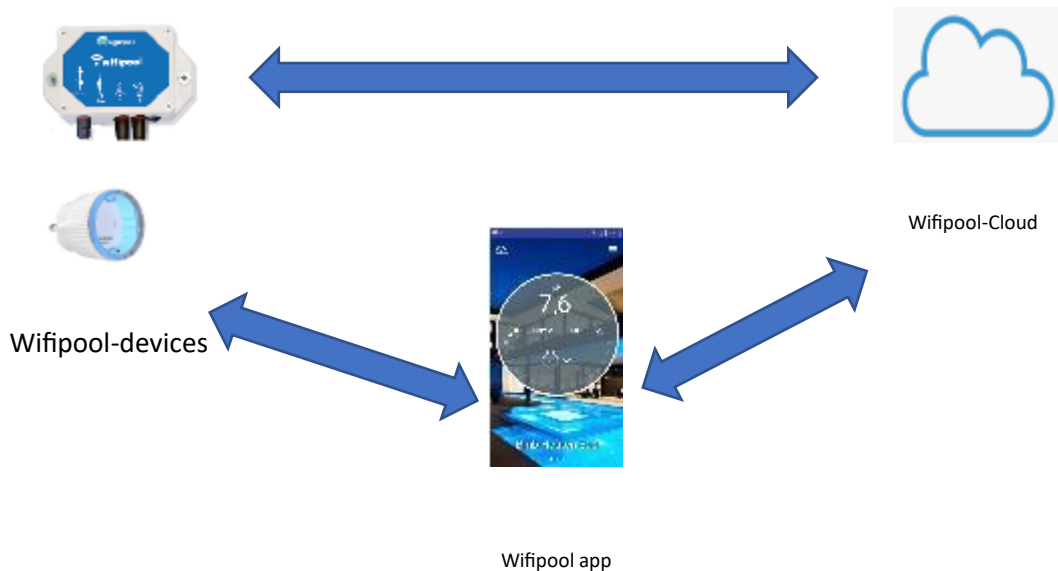

After pairing, the Wifipool devices will send data to the cloud, and they will receive instructions from the cloud. The communication occurs over the home Wi-Fi network and can be configured and monitored via the mobile phone.

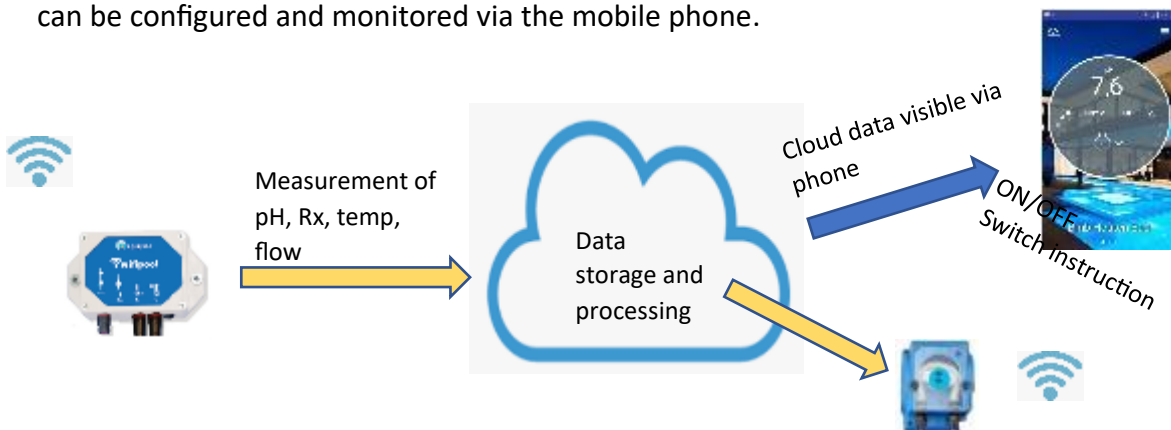

2.2. Problems with pairing

To ensure successful pairing, it's crucial to follow each step accurately. Both Android and iOS programmers have implemented intricate security measures, complicating the pairing process with several invisible security checks that must be confirmed.

The primary reason for pairing failures often stems from the instability of the home network. We strongly recommend conducting the pairing process indoors, close to the network source, and PRIOR to the physical installation of the devices. If you have a Gen2 Wifipool device, we recommend to pair via a ethernet connection.

Generally, pairing with Android proves to be easier compared to iOS. It's feasible to initially pair pool devices with an Android phone and then transfer ownership to an iOS device using the "Add user" feature (as mentioned above).

Once the pairing is complete, network stability becomes less critical. With Gen 2, these steps have been significantly streamlined, requiring only one-time pairing. Furthermore, it's not mandatory to pair via Wi-Fi; a cable connection is also an option, enhancing both the ease and reliability of the process.

2.3. Before pairing

If the board is not yet connected to a pool and no Ethernet connection has been established, the LED in the top right corner of the board will flash. In all other scenarios, it will not flash. This is the case when the board is already connected to a pool, either via Ethernet or WiFi. In this case, the LED will not flash, regardless of the type of connection (Ethernet or WiFi). It is important to note that if the LED on the board is flashing when the Ethernet connection is present, this does not mean that a connection to the Internet is available. If the Ethernet port is not flashing, no Internet connection is available.

Gen 1 (without) Ethernet

Led flashes when they are not paired and lights up 100% of the time after pairing. If they do not light up, they have no power, or the programming is wrong.

In previous generations, the red Shellys do not flash when they are not paired. However, the blue Shellys flash to indicate that they are ready to pair.

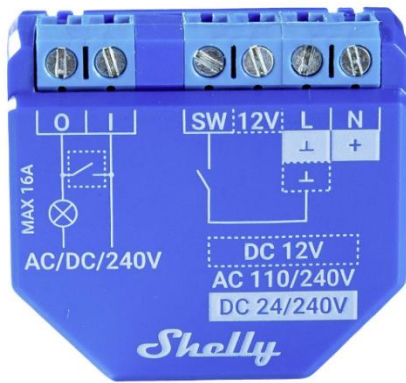

Both the small and the large plugs flash blue



First, ensure that the "Auto-join" feature in your Wi-Fi settings is activated. Without enabling this option on your smartphone, the network won't automatically reconnect, potentially causing issues when pairing your device. To activate this feature, navigate to the Settings app on your smartphone, then select "Wi-Fi" and tap the information ("i") icon. From there, toggle the "Auto-join" option to on, and proceed with the instructions below.

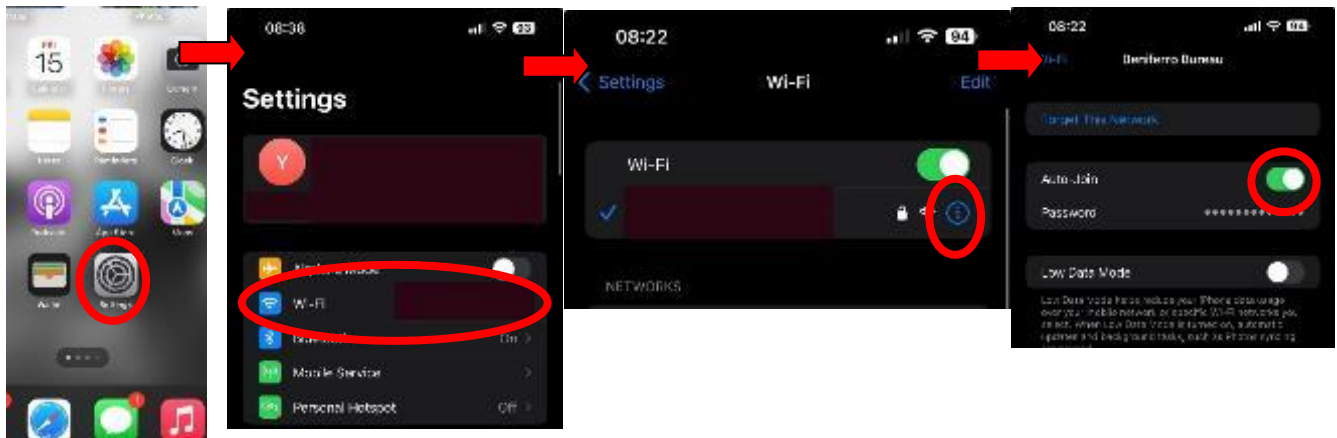

Before pairing with ethernet-connection:

1. Install the Wifipool app on your phone (as mentioned above).
2. Ensure you have an ethernet cable and connected to your device.



3. Make sure you have the instruction page (included with your order) with the device serial number and barcode. (See appendix 1).

Before pairing without ethernet connection:

1. Install the Wifipool app on your phone (as mentioned above).
2. Ensure you know the network names and password of your Wi-Fi network that you will use for your swimming pool.
3. Make sure you have the instruction page (included with your order) with the device serial number and barcode. (See appendix 1).

Additional Notes:

1. Take your time. The pairing process will take 5-30 minutes, depending on the number of devices to pair and the technique used.
2. Make sure the wifi products are used within the required technical specifications (see appendix 3), such as 2.4GHz wifi network, -20 to 70°C, dry environment, etc.
3. If the circuit board is not yet connected to a swimming pool and no Ethernet connection has been established, the LED on the top right corner of the circuit board will flash. In any other scenario, it will not flash. This applies when the circuit board is already connected to a pool, either via Ethernet or WiFi. In this situation, the LED will not flash, regardless of the connection type (Ethernet or WiFi). It is important to note that the flashing of the LED with the Ethernet connection on the circuit board is does not mea that a connection to internet is available. When the ethernet connector does not flas, no internet connection is available.

2.4.Pairing via ethernet

Pairing via ethernet is the preferred pairing method. The method is only available for Wifipool devices containing an ethernet connection, produced from 2024 onwards.

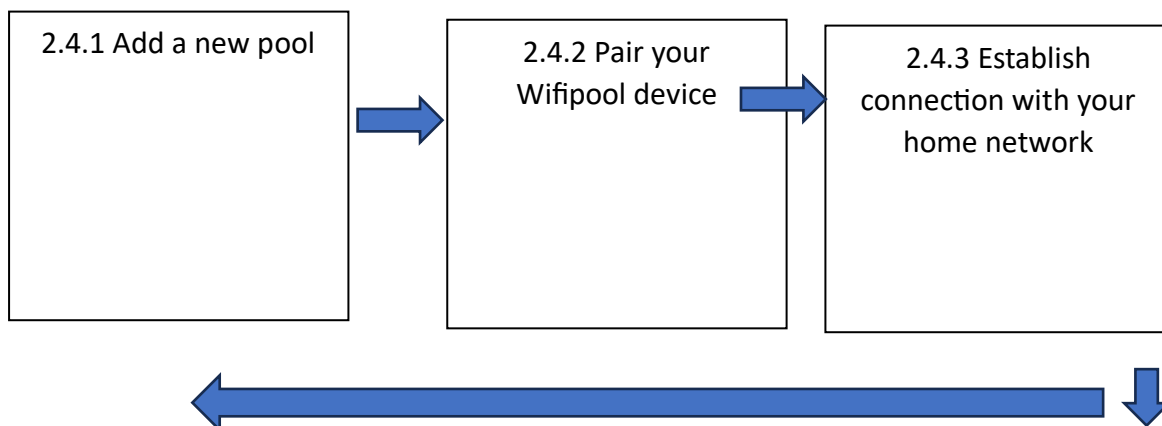

2.4.4 The device is added , automations are loaded and the phone returns to the Pool settings screen



2.4.5 Finalizing installation

2.4.1 Add new pool

Firstly, make sure you add a new pool, give it a unique name .

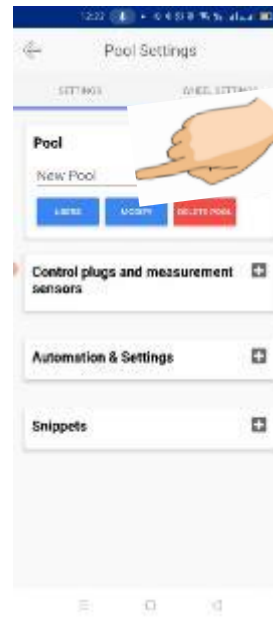
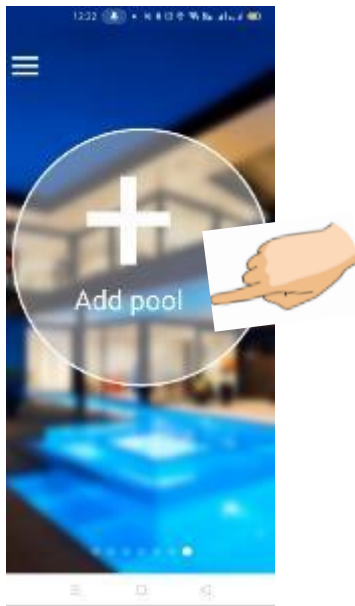

2.4.2 Pairing Wifipool device

Tap the plus icon next to "Control plugs and measurement sensors."

Always ensure that you connect your device using an Ethernet cable to establish a stable connection. If your router flashes a light, it indicates that the connection is successful.

Then, where it says "Scan the bar or 2D (QR) code on your device," tap "Start scanning" and proceed to scan the barcode on your device or on the "Startup information sheet" included in the box.

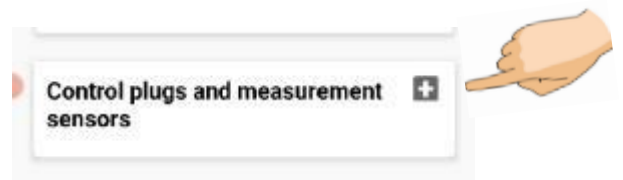

2.4.3 Connect to home network

The next step is different for Android vs IOS.

Android : you have to select your home network : the network which you will use for your swimming pool equipment.

IOS : You will have to enter the Swimming pool network name (SSID) and password manually.

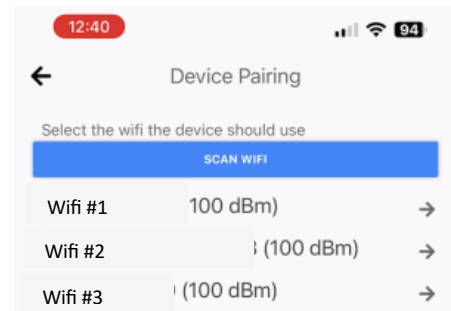

Enter your wifi informations

SSID

Password 

CONFIRM

Enter the correct password. Press the eye and check your password carefully, if you enter the wrong password, the app will go back to the main menu and your device will only remain connected as long as the device has ethernet connection. As soon as the ethernet cable is removed, connection will be lost.

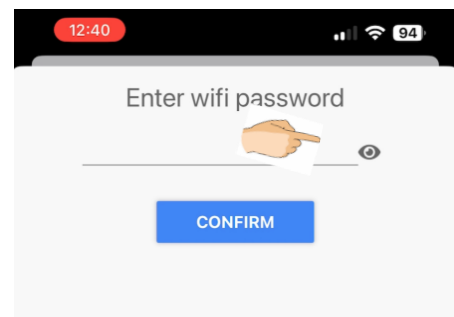

2.4.4 The device is added and the phone returns to the Pool settings screen

The app will return to the main screen. If not, close the app and open it again. A first device is now paired, and you will see the device in the Pool settings page.



2.4.4.1 Predefined Automation & Settings

With Gen 2, there may be predefined automation settings already configured. After installation, you can find them under "Automation & Settings." These settings are automatically activated once you start using them.

2.4.4.2 Wrong Wi-Fi password entered (ethernet)

In case your device is connected via ethernet, there won't be any error message if you have entered the wrong password. The menu will show a red signal next to your connection. Just unpair the device from the Wifipool app and go back to step 2.4.2

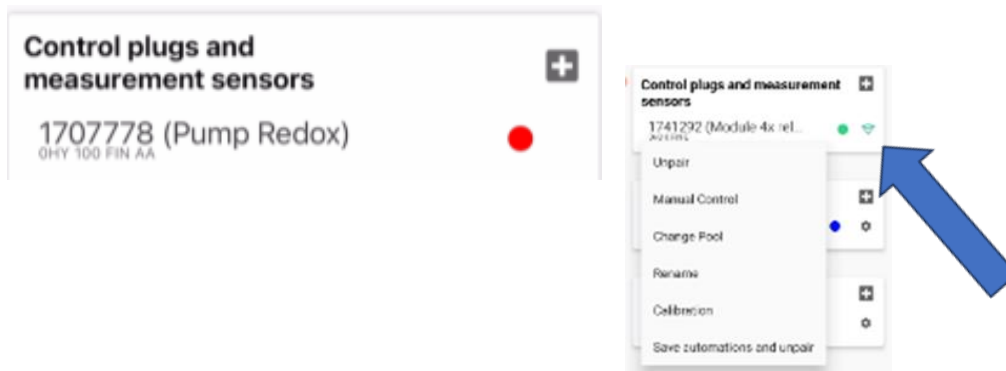

2.4.5 Finalizing installation

After the installation process is finished, go back to your pool settings.

Check if your control plugs and measuring modules are paired and functioning. If the indicator light turns green, it means they are paired. If it's red, it means there's (still) no connection. Always wait a moment until the indicator light turns green as it may take some time.



Note: Beniferro does not offer free technical support for pairing issues via Wi-Fi if you have an Ethernet device.

In case you have pH and RX probes, you need to calibrate your Wifipool device. This simple calibration process is explained in the quickstart manual of the equipment purchased

(More info about calibration, see chapter: Calibration) Once calibrated, you can seamlessly proceed with the physical installation of the device, ensuring optimal performance and accuracy in monitoring your pool's environment.

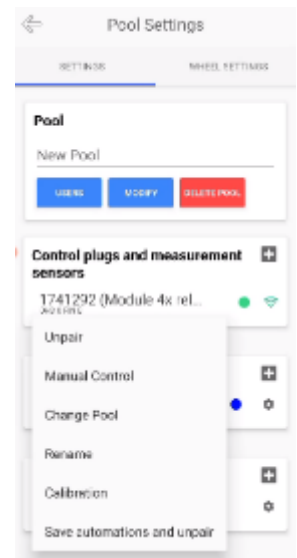

2.6. Pairing of the WIFIPOL-devices via Wifi for iOS devices.

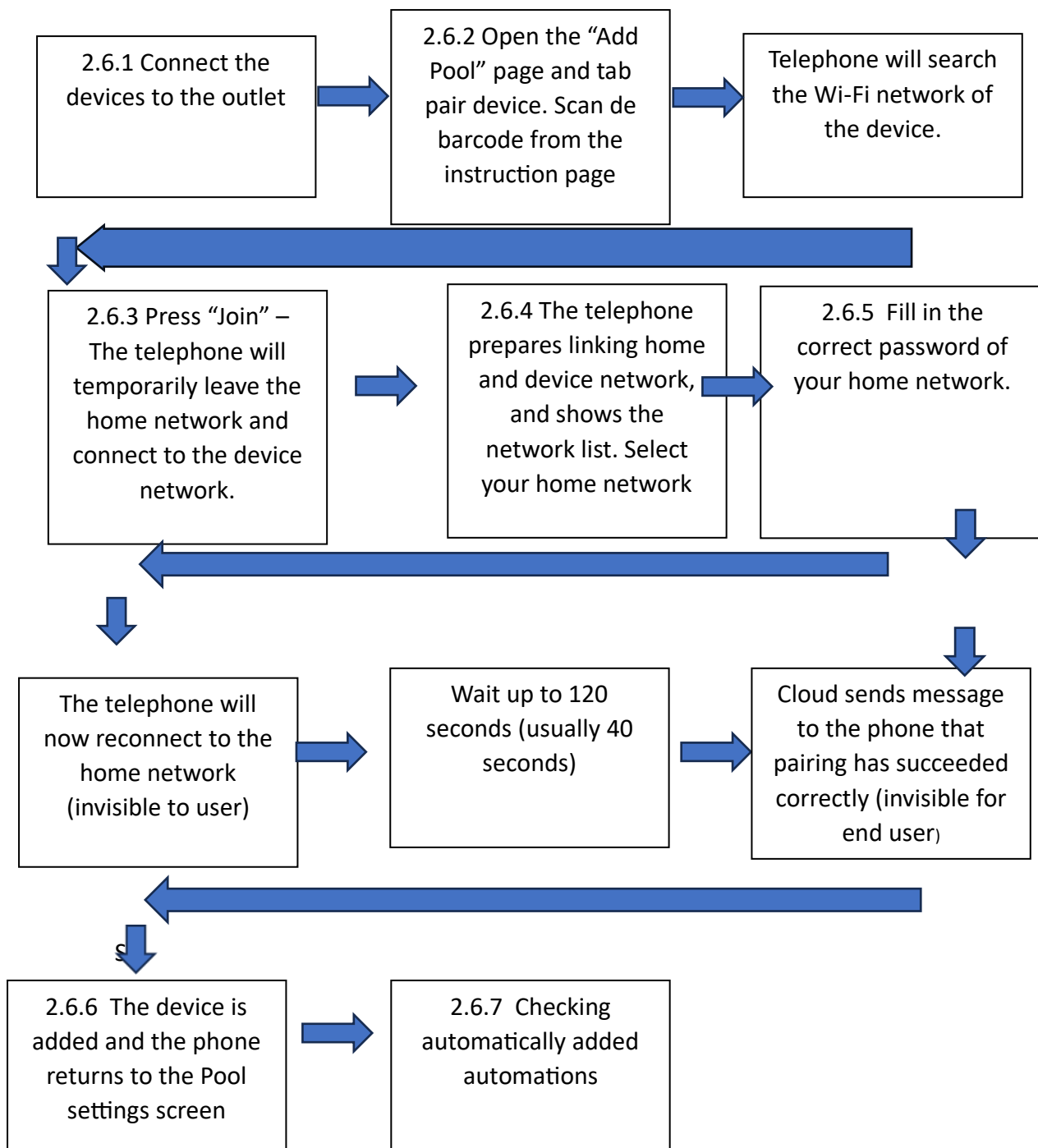

This pairing method is mandatory for Gen 1 devices (no ethernet connections) and is optional (but not recommended) for GEN 2 devices with ethernet connector.

The pairing needs to be completed for all the devices, before the pool automation can be entered into the system Please note: The manufacturer does NOT give free support for this pairing process if pairing via ethernet of webpage are available for your device.

2.6.1 Connect the devices to the outlet

After connecting the power, the Wifipool devices will emit a Wi-Fi signal. You will see the SSID of the devices in the available Wi-Fi list of your phone. The SSID is a combination of 6 and 4 letters/digits

In this example, there is a SSID for a pH pump, a salt electrolysis, a pH measurement and a Redox measurement.

Please note: If everything is paired successfully, you will no longer see these devices in your Wi-Fi settings

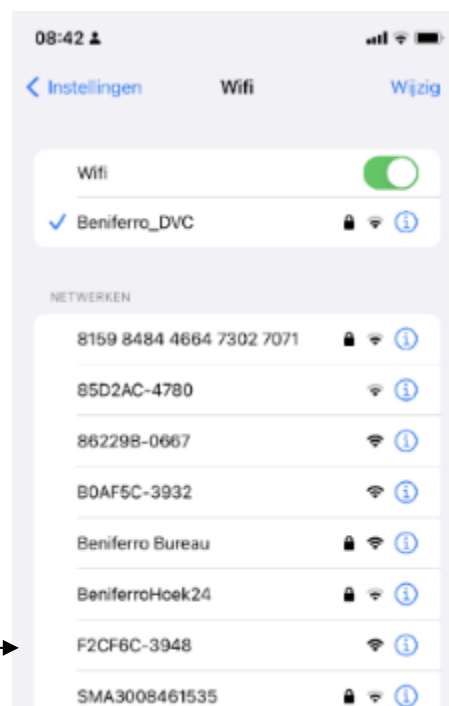

2.6.2 Connect the devices to your phone one by one. To do this, go to the pool settings on the Main screen and tick the Pool name (1), and press 2 on the "Control Plugs and Measurement Sensors" section and press + (press 2). Scan the first barcode on the instruction sheet that came with the products you purchased.

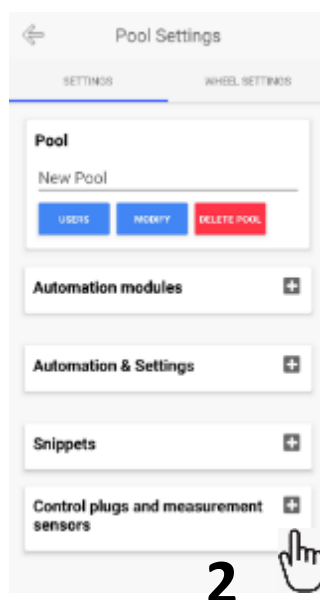

Start scanning



2.6.3 Press “Join” – The telephone will temporarily leave the home network and connect to the device network.

After scanning, a short notification will be displayed indicating that the Wi-Fi pool device is being connected to the phone.

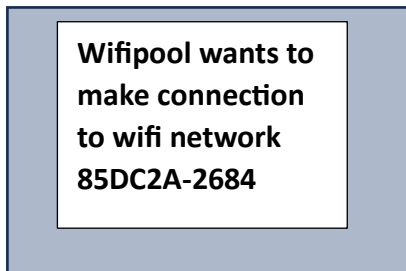

The app will start searching for your WiFi networks, your device would no longer show the WiFi icon at the top right for a short moment.

2.6.4 The telephone prepares linking home and device network, and shows the network list. Select your home network : the network which is most active around your pool.

2.6.5 In the next step you have to select your home network : the network which you will use for your swimming pool equipment.

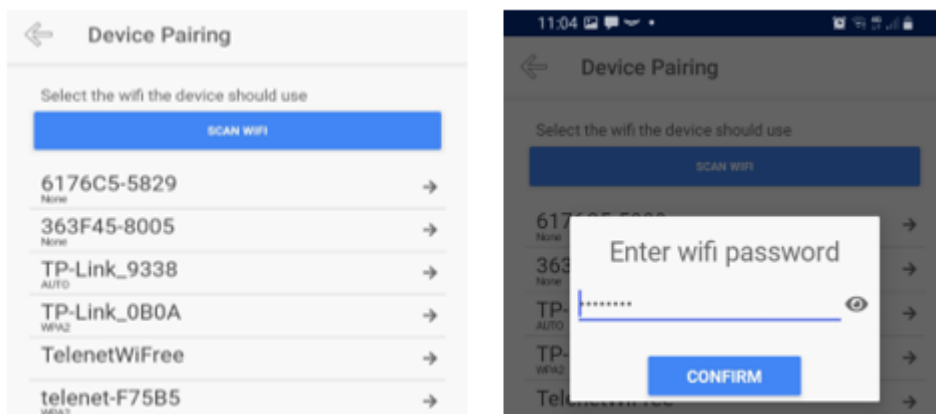

Enter the **correct** password Press the eye and check your password carefully, if you enter the wrong password, the app will go back to the main menu and show the following message: "The pairing process has failed".

The wrong password will now be saved, so if you reuse the saved password on a next attempt, the attempt will fail again.

If the correct password is entered, the phone will now start searching for the network and start the pairing process. During this period, do not interrupt the system, do not move the devices or the phone. Just be patient and wait. It takes usually +- 40 seconds to complete the process, but on other occasions it may take up to 120 seconds.

The last step of this process is a communication from the cloud to your phone (message not visible for end user), that the pairing process was successful.

2.6.6 The device is added and the phone returns to the Pool settings screen



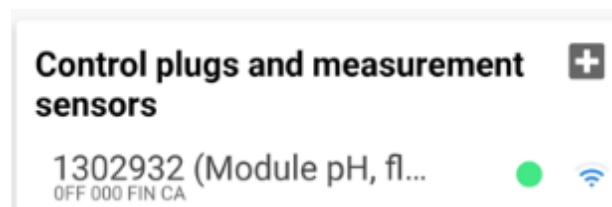



The app will return to the main screen. If not, close the app and open it again. A first device is now paired, and you will see the device in the Pool settings page.



2.6.7 Connect remaining devices

Repeat steps 2.6.1 to 2.6.6 until all devices are paired. You will now see your devices in the Pool settings page. A red circle behind the device indicates the device is not connected to the Wi-Fi. A green circle means the device is connected.

Control plugs and measurement sensors

1302901 (Module pH, fl... <small>OFF 000 FIN CA</small>		
1439745 (Module pH, fl... <small>OFF 000 FIN CA</small>		
1090507 (Plug 16A) <small>OGZ 000 FIN AA</small>		
1352157 (Module Temp... <small>OFF 200 FIN CA</small>		

2.6.8 Checking automatically added automations

Ensure to first verify whether any preprogrammed automations (appendix 1) are already present. This may be the case if you just paired a Gen 2 device. These will conveniently appear under the section titled “Automation & Settings”. Should you find that there are no automations listed, take the initiative to manually incRXorate them by scanning the provided barcodes. This step ensures comprehensive control and optimization of your device's functionalities. See the quick start-up manual of the equipment purchased.

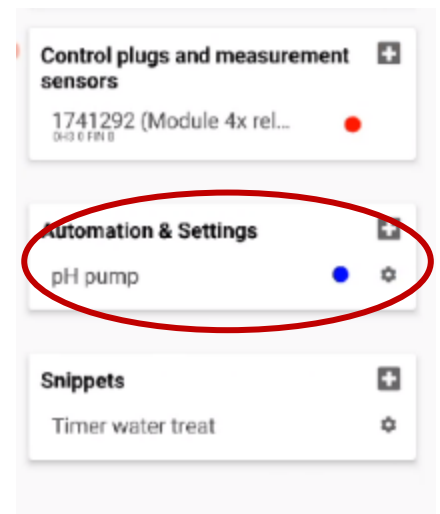

a. Pairing the WIFIPPOOL devices via WIFI on a Android phone

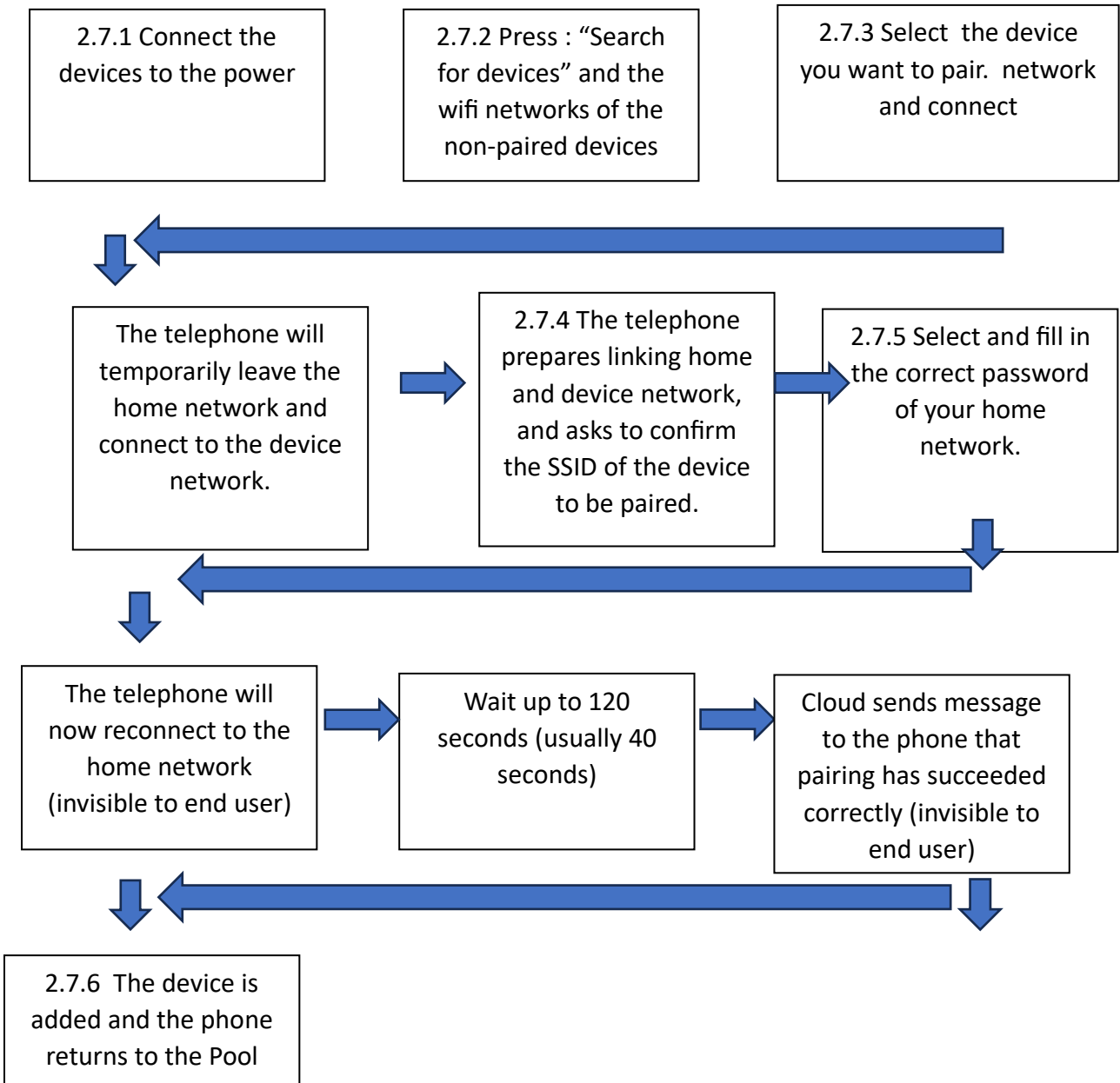

The pairing needs to be completed for all the devices, before the pool automation can be entered into the system

Attention : The manufacturer does NOT give free support for this pairing process if pairing via ethernet or webpage are available for your device.

2.7.1 Connect the devices to the power

After connecting the power, the Wifipool devices will emit a Wi-Fi signal. You will see the SSID of the devices in the available Wi-Fi list of your phone. The SSID is a combination of 6 and 4 letters/digits

- letters/digits
- In this example, there is a SSID for a pH pump, a salt electrolysis, a pH measurement and a Redox measurement.

Please note: If everything is paired successfully,

- you will no longer see these devices in your Wi-Fi settings

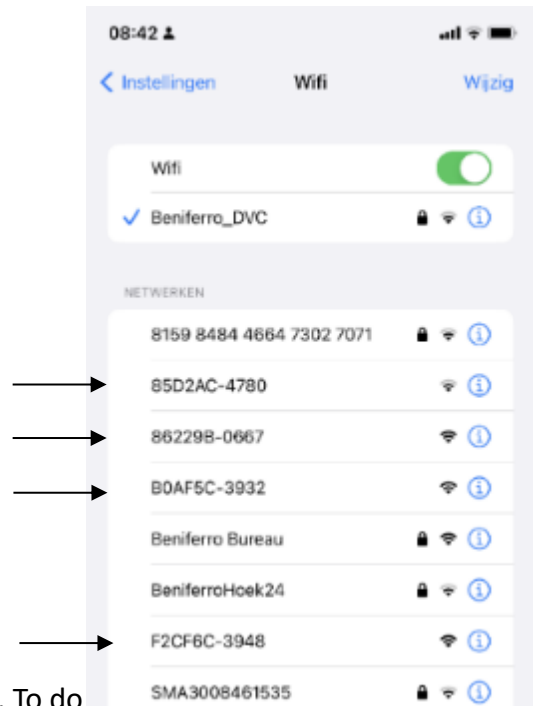

2.7.2 Connect the devices to your phone one by one. To do this, go to the Main screen and tick the Pool name (1), and on the "Control Plugs and Measurement Sensors" section press + (2). Subsequently start the « search for devices »(3), and select the device you want to pair (4).

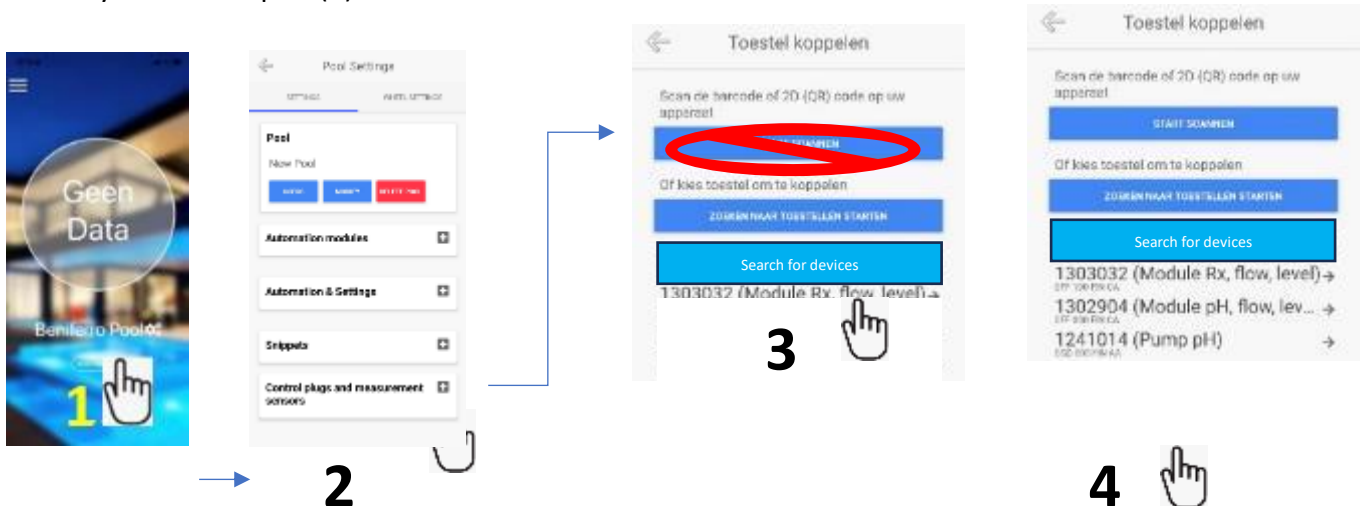

2.7.3 Press "Connect" – The telephone will temporarily leave the home network and connect to the device network.

2.7.4 The telephone prepares linking home and device network, and asks to confirm the SSID of the device to be paired.



2.7.5 In the next step you have to select your home network : the network which you will use for your swimming pool equipment.

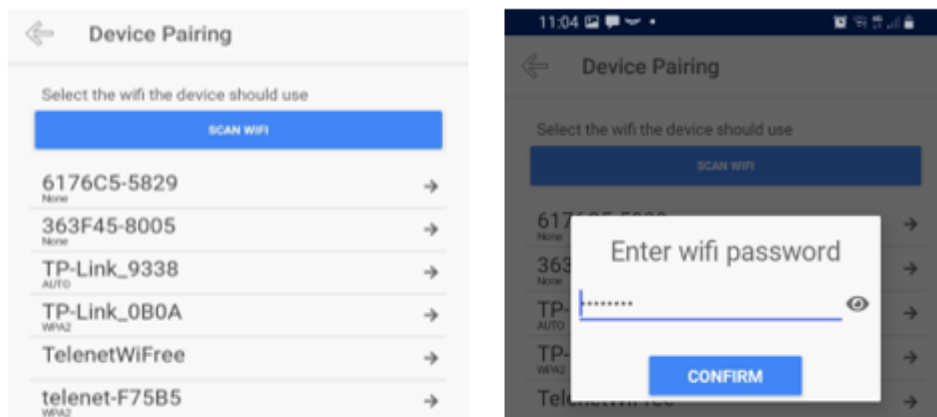

Enter the **correct** password Press the eye and check your password carefully, if you enter the wrong password, the app will go back to the main menu and show the following message: "The pairing process has failed".

If the wrong password is entered and saved, subsequent attempts with the same password will also fail. However, if the correct password is entered, the phone will initiate the network search and begin the pairing process. It's crucial not to interrupt the system during this period or move the devices or phone.

Please be patient and wait. Typically, this process takes approximately 40 seconds to complete, but in some cases, it may take up to 120 seconds. The final step involves a

communication from the cloud to your phone (a message not visible to the end user) confirming that the pairing process was successful.

2.7.6 The device is added and the phone returns to the Pool settings screen or to the main screen. If not, close the app and open it again. A first device is now paired, and you will see the device in the Pool settings page.

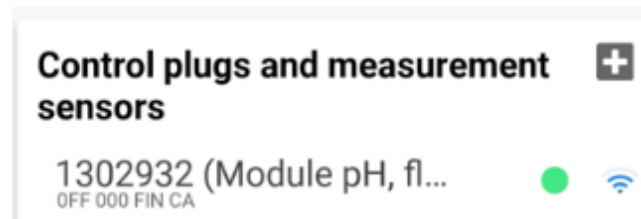

2.7.7 Connect remaining devices

Repeat steps 4.4.1 to 4.4.6 for each device until all devices are paired. Once paired, you will see your devices listed in the Pool settings page. A red circle behind the device indicates that the device is not connected to Wi-Fi, while a green circle signifies that the device is connected.

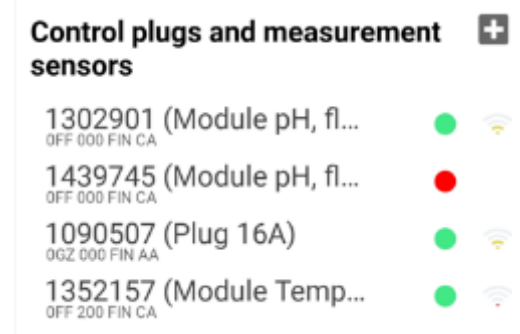

2.7.8 Checking automatically added automations

Ensure to first verify whether any preprogrammed automations (appendix 1) are already present. This is the case for GEN2 devices. These will conveniently appear under the section titled "Automation & Settings". Should you find that there are no automations listed, take the initiative to manually incorporate them by scanning the provided barcodes. This step ensures comprehensive control and optimization of your device's functionalities. Barcodes and instructions are found in the quick startup manual of the device purchased.

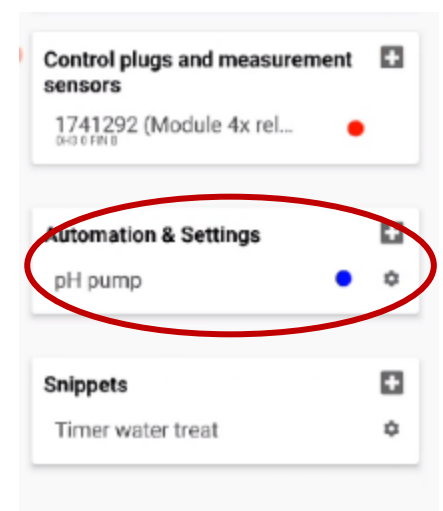

2.8 Pairing Problem solving IOS and Android

Step 2.6.6 / 4.5.6 Error: Wi-Fi connection failed - Possible causes:

- The home Wi-Fi network is not strong enough, unstable or absent in the zone in which you want to pair.

Solution for Gen 1:

Check that your phone is connected to your home network used for the pool. If not, select the appropriate network and ensure the phone remains connected during the pairing process.

Verify that the Wifipool network(s) in the format of 6 Characters/Digits - 4 Characters/Digits (e.g., 85C927-2343) is/are present in your phone's networks. Each unpaired device should display a network. After a power outage, it may take up to 3 minutes for the network to be visible.

If the device network is visible: Attempt to pair again from step 2.6.2.

If the device network is not visible, ensure the device is plugged in correctly (check the USB plug). If plugged in correctly, then reset the device by plugging and unplugging 7 times (each approximately 2 seconds). Wait until the Wifipool network is visible and your phone is connected to the correct home network, then attempt pairing again in the strong network zone from step 2.6.2.

If the error persists, contact your supplier after reading the section: 'What to do if I need to contact the supplier?'

Solution for Gen 2:

Check that your phone is connected to your home network used for the pool. If not, select the appropriate network and ensure the phone remains connected during the pairing process.

Verify that the Wifipool network(s) in the format of 6 Characters/Digits - 4 Characters/Digits (e.g., 85C927-2343) is/are present in your phone's networks, or for gen 2 devices, there can be more characters/digit – 9 digits and 4 characters (e.g., 975C93534-3850) . Each unpaired device should display a network. After a power outage, it may take up to 3 minutes for the network to be visible.

If the device network is visible: Attempt to pair again from step 2.6.2.

If the device network is not visible, ensure the device is plugged in correctly (check the USB plug). Unplug the device and wait 40 seconds and plug it back in. Wait until the Wifipool network is visible and your phone is connected to the correct home network, then attempt pairing again in the strong network zone from step 2.6.2.

If the error persists, contact your supplier after reading the section: 'What to do if I need to contact the supplier?'"

There is no assistance for WiFi connection problems, so pairing via ethernet is recommended

Step 2.6.6 / 2.7.6 Error: Pairing failed

Possible causes:

The home and/or device Wi-Fi network isn't strong enough or absent from the zone where you want to pair. Make sure your phone is near both home Wi-Fi and device Wi-Fi. Best is to do the pairing in-house before installing the pool equipment.

Solution:

1 Wait another 60 seconds after seeing the error message and verify if the device is not paired after all. If so, you will see your device on the Pool Setting page.

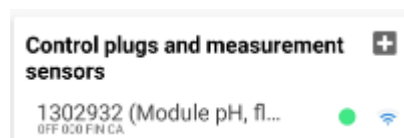

2. Check that the Wifipool network(s) in the formats 6 Characters/Digits - 4 Characters/Digits - For example, 85C927-2343 is/are present in your phone's networks. For each unpaired device, a network is visible. After a power outage, it takes up to 3 minutes for the network to be visible.

If the device network is visible : Try to pair again from step 2.6.2 / 2.7.2

If the device network is not visible, verify that the device is indeed plugged-in (also check that the USB plug is working correctly). If plugged in correctly, then reset the device by plugging in and unplugging 7 times (each +- 2 seconds). Then wait until you can see the Wifipool network and that your phone is connected to the correct home network, and try again to pair in the strong network zone from step 2.6.2 / 2.7.2

If the operation 7 times (each +- 2 seconds) has not worked, verify that the home network is indeed powerful at the location of the device. If the device is left for 15 minutes in the strong network zone to which it was paired (or partially paired), the device may reset itself.

If this error returns, contact your supplier after reading the section : What to do if I need to contact the supplier ?

Step 2.6.6 . 2.7.6 Error: Pairing Process failed - Possible causes:

Possible cause : The password you use for your home Wi-Fi network was entered incorrectly (and the wrong password was saved).

After a 120 minutes waiting time, a error message will display : The pairing process failed. Home network instability, or not strong enough in the pairing zone or too much distance between device, home network and phone.

Solution: Enter the password manually and verify the password when pairing the devices.

Step 2.6.6 / 2.7.6 : Error: "wrong password"

Issue 3: "Wrong Wifi password"

Possible causes:

1. You entered the wrong password
2. You switched the pairing methods from Ethernet to non-Ethernet

Solution:

1. Try pairing again and make sure to fill in the right password.
2. Reset the plug or the measuring box by disconnecting it from the power outlet for 30 seconds and then plugging it back in.

If you are connecting with Ethernet, make sure to plug in your cable before pairing. If you are connecting with Wifi, make sure there is definitely no Ethernet cable connected before pairing.

Step 2.6.2 / 2.7.2 : "Unable to connect to network 'Wi-Fi pool device name'

Possible causes:

The Wi-Fi pool device Wi-Fi network is not strong enough or absent in the zone in which you want to perform the pairing.

Your phone is too far from the Wi-Fi pool device



Solution:

1. Check that the Wifipool network(s) in the formats 6 Characters/Digits - 4 Characters/Digits - For example, 85C927-2343 is present in your phone's networks. For gen2 there can be more characters/digits. For each unpaired device, there is a network. After a power outage, it takes 3 minutes for the network to be visible.

If the network is visible: retry to pair from step 2.6.2 / 2.7.2 in a zone where all the networks (Wifipool networks and your home pool network) are strong.

If the device network is not visible, verify that the device is indeed plugged-in (also check that the USB plug is working correctly). If plugged in correctly, then reset the device by plugging in and unplugging 7 times (each +- 2 seconds). Then wait until you can see the Wifipool network and that your phone is connected to the correct home network, and try again to pair in the strong network zone from step 2.6.2

If the operation 7 times (each +- 2 seconds) has not worked, verify that the home network is indeed powerful at the location of the device. If the device is left for 15 minutes in the strong network zone to which it was paired (or partially paired), the device may reset itself.

If this error returns, contact your supplier after reading the section : What to do if I need to contact the supplier ?

Step b2 2.6.2 : Home Wi-Fi network is not visible

Solution: On iPhone the network screen doesn't always show up over the full length of the device. Scroll down the network list to check if you can see the network.

Step b2 2.6.2 : Wi-Fi network are not displaying correctly (undefined NaN dBm)

Solution: press the "scan Wi-Fi" button multiple times until your networks are accurately detected and displayed.



Step 2.6.2 / 2.7.2 : "The device cannot be paired because it is already connected to another pool"

Solution:

Check if you can see the device in the pool settings page . If this is the case, everything is fine.

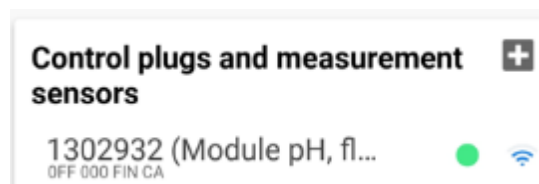
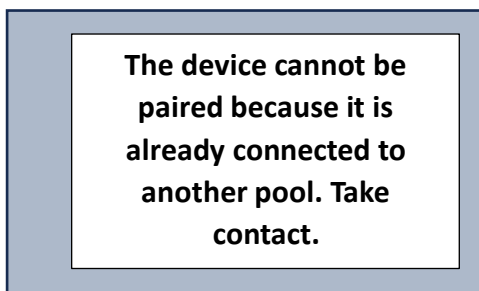

If the device network is not visible, verify that the device is indeed plugged-in (also check that the USB plug is working correctly). If plugged in correctly, then reset the device by plugging in and unplugging 7 times (each +- 2 seconds). Then wait until you can see the Wifipool network and that your phone is connected to the correct home network, and try again to pair in the strong network zone from step 2.6.2 / 2.7.2

If this error returns, contact your supplier. It can remotely perform an additional reset of the Wi-Fi pool device.

What to do if I need to contact the supplier ?

Please act as follows:

1. Plug in and out the devices that are not working
2. Please send a photo of the barcodes provided for pairing. These can be found on the Connect Go/Pro control box or on the pairing instruction sheet included with the delivery.



3. Send a screenshot with all your home networks. All devices should be shown on the screenshot.

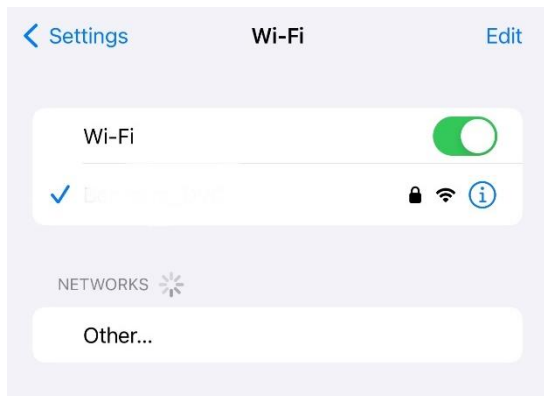

Please wait until all the networks are displayed, and then send a screenshot of the entire list.

4. Send a screenshot of the pool settings where we can see the control plugs and measurement sensors that are paired

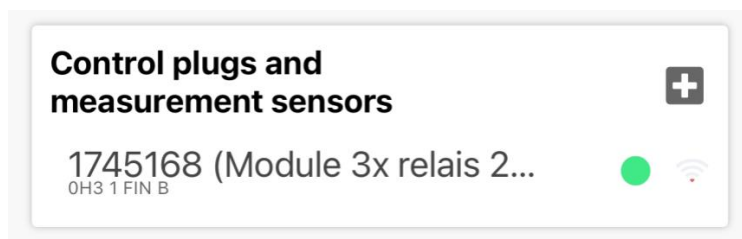

5 Add info@beniferro.eu as user to your pool, promote 2 times to the level of co-owner.

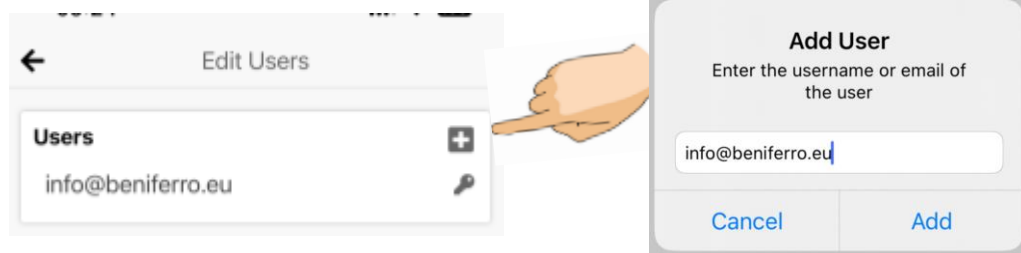

See section 3.1.1.2.1 below

Please send this information along with the problem description and the name of your pool to info@beniferro.eu.

3. Using the Wifipool app

3.1. Pool Settings

The Pool settings page is the page with which you will add new equipment (such as plugs and measurement boxes) , and define how your pool will be controlled. Via this page you can add additional users, edit the pool characteristics and verify the status of devices and automations.

There are 2ways to enter the Pool settings page :

From the main page click directly on your swimming pool name or on the 3 bars in the top left corner

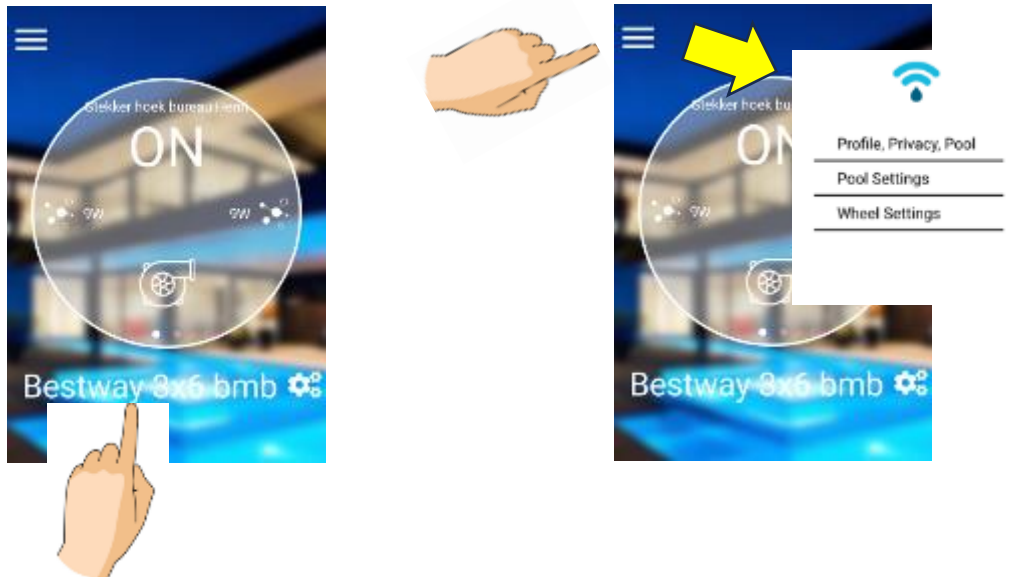

3.1.1. Pool

3.1.1.1. Pool Name

Give your swimming pool a name. In case you share your pool with other people (see “users”, it is important to choose a recognizable and original name. Type in your new pool name in the text field.

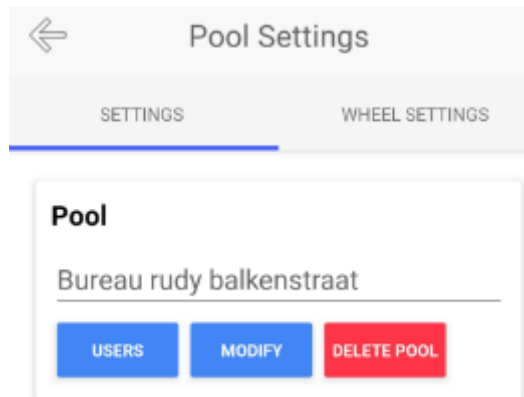

3.1.1.2. Users

3.1.1.2.1. Adding users

Via the "Users" tab, you can let other people watch or control your pool.

Go to the pool settings page and select users

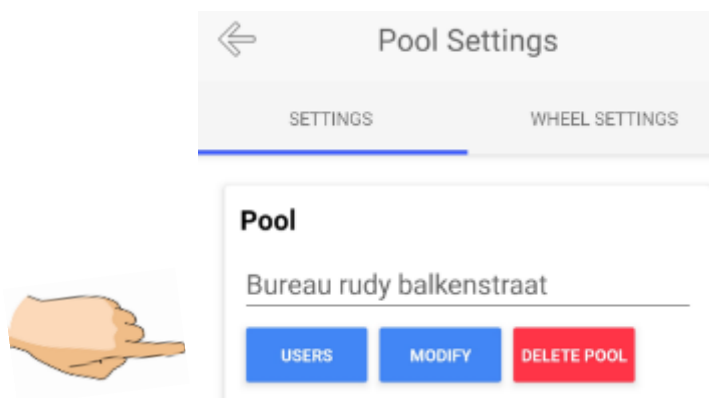

You can now add users to your pool. Click on the little plus symbol in the right top corner of the screen. The user is directly added to the pool. This user is "Read only" (3.1.1.2.1).

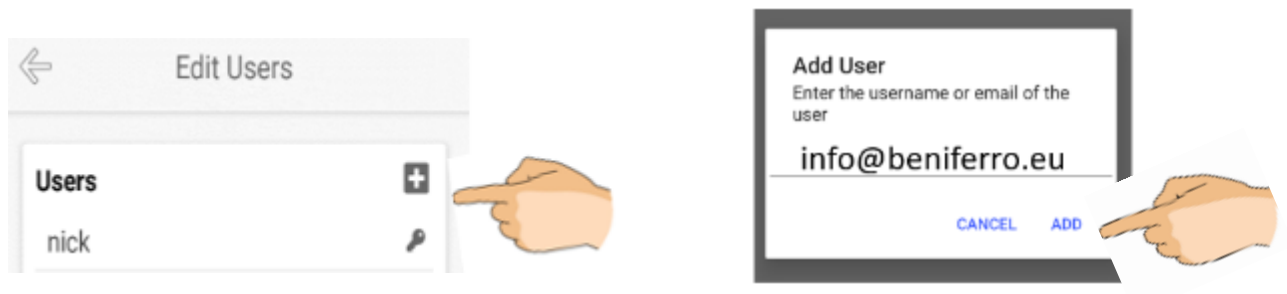



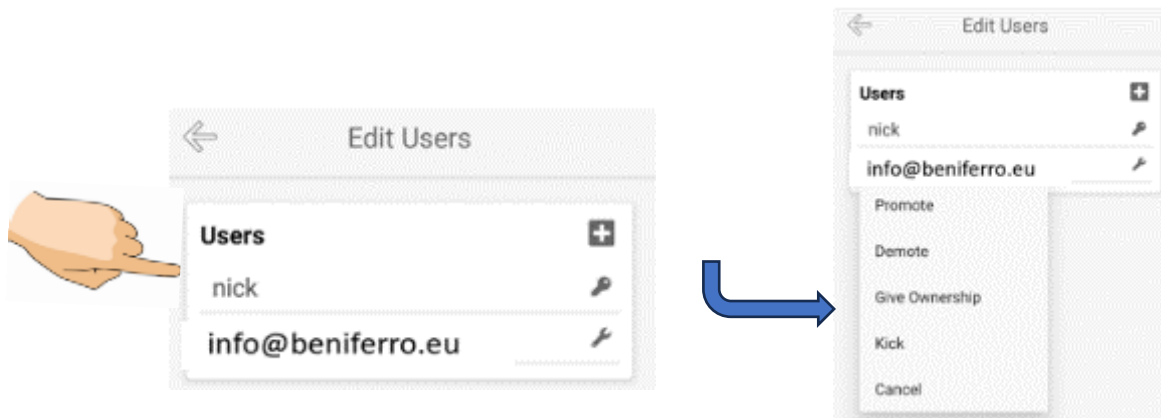

A popup window appears where you can type in the Wifipool username of the person you want to add.

3.1.1.2.1. Manage user rights

Click on the name of a user from the menu



There are 4 levels of restrictions you can add for each User

-  Owner : can control the swimming pool, add, promote, give ownership and kick out users
-  Co-owner : can control the swimming pool and add and promote users
-  Partner : can look at the swimming pool and receive notifications
-  Read only

Be aware that once you give up your own rights as an owner and this user now has the rights to kick you out as a user.

By promoting info@beniferro.eu to the level of co-owner, you can give the manufacturer access to your pool. This is a helpful feature in case help or troubleshooting is requested. In this case, make sure your pool has a recognizable and original name.

3.1.1.3. Modify Pool Characteristics

By pressing the modify button, you can edit and change your Pool characteristics. Filling in the Pool characteristics (such as Pool volume / Pool type...), will allow the app, to send you advice on your pool.

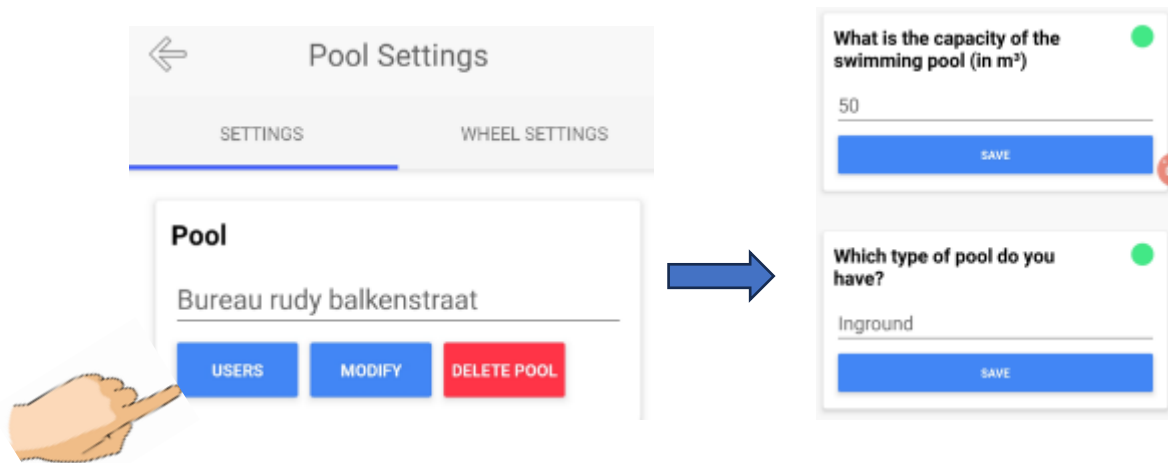

3.1.1.4. Delete Pool

Using this option will fully delete your pool, all pairing and automations. This action cannot be restored.

Please note: if you happened to delete your pool by accident. You have to manually reset your devices connected to the swimming pool.

3.1.2. Control plugs and measurements

The “Control plugs and measurements” section allows the user to have a quick overview of the devices in the swimming pool and their connection to the wifi network.

In addition, some direct controls such as calibration, manual control etc. are initiated via this section.

Before a device can be used, it needs to be paired with your home network and telephone. The pairing process of the control plugs and measurement devices has been described above.

After pairing, all devices are listed. The green circle indicates the device is connected to Wi-Fi, a red circle is not connected to the Wi-Fi. The number in front of each device is the serial number of the device.

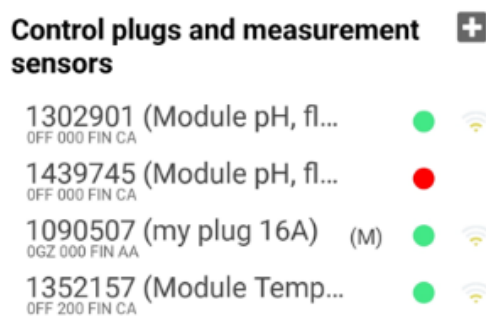

3.1.2.1. Unpair

The unpair / delete option will „delete“ a device, and make it available for other users / other swimming pools; Tick on the device name in “control plugs and measurement sensors”, followed by “unpair or delete”.

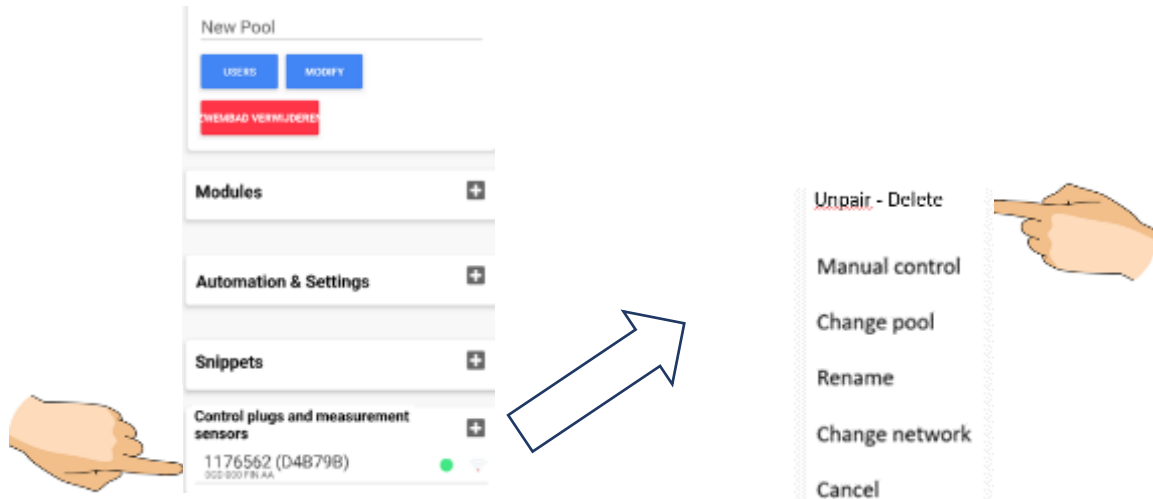

3.1.2.2. Manual control

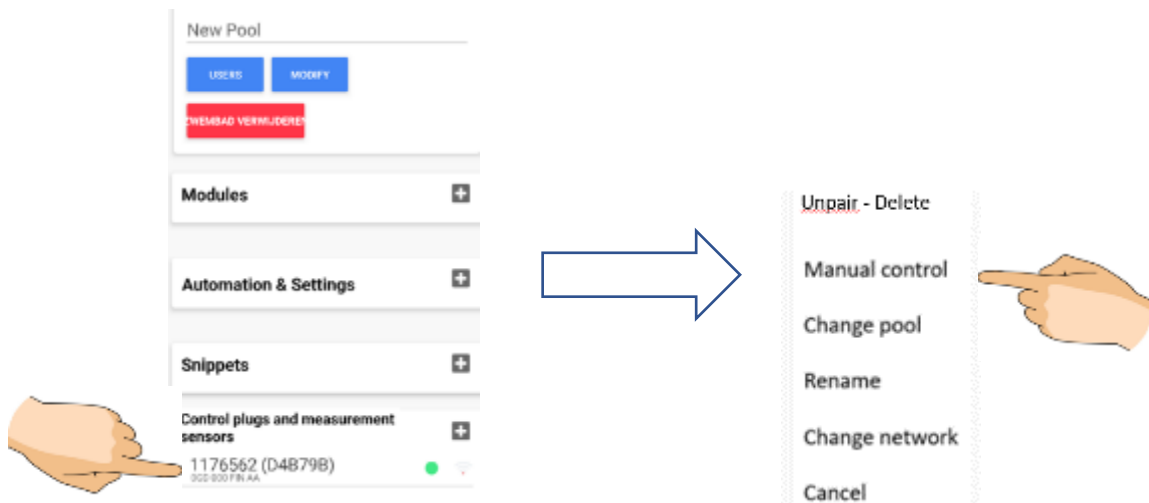

Click on manual control to switch from automatic to manual control. When using manual control, the owner, co-owner and partner of the Wifipool account, can start and stop manually the plug or smart switch. Although manual control can be helpful, it also contains risks. In case the pH peristaltic pump is started manually, it will keep on dosing liquid into the pool, regardless if this is needed or not.

Therefore, it is necessary to acknowledge that you have been informed of the risks associated with manual control, before you can access the control itself.

Once entered the manual control, it is possible to return to automatic via the green “switch to automatic button” . You can toggle the pump (or other device) on or off by tapping or swiping the grey toggle to the left or to the right.

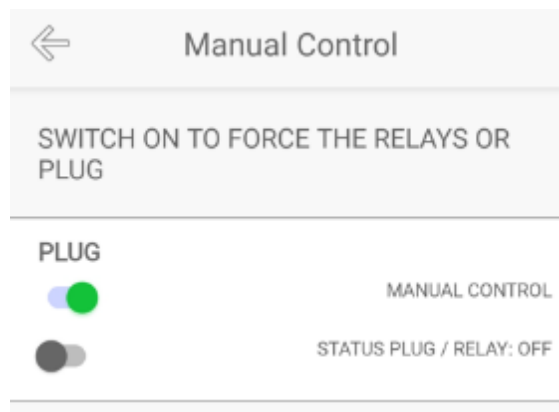

On the Pool setting screen, plugs and smart switches in manual mode, will be indicated with a “M” .Upon hitting the device name, a menu will unfold, by which it is possible to return to the automatic mode



3.1.2.3. Rename

Select Rename and enter in the new name for your plug. It is advisable to select a name which makes it clear which equipment this plug is controlling (eg Filter pump, pH peristaltic pump

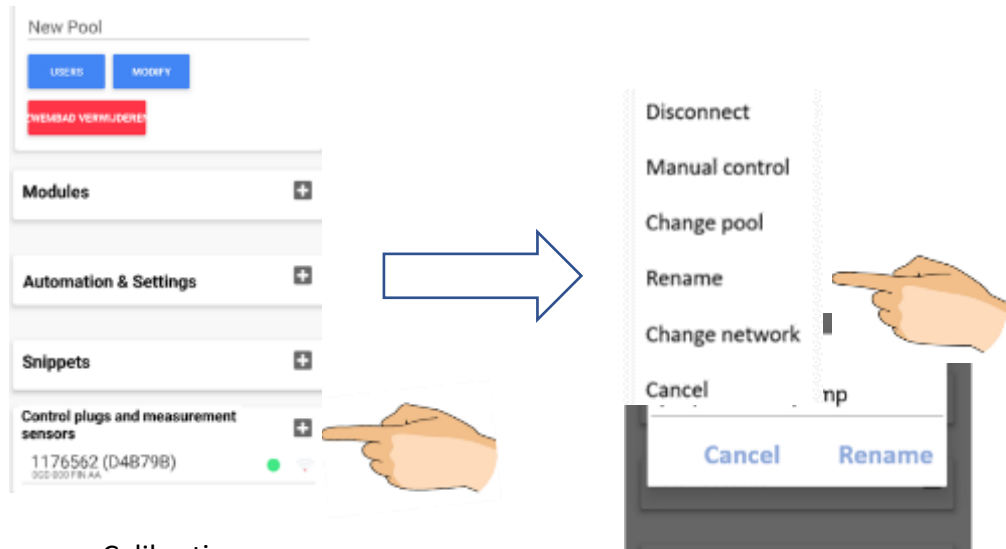

3.1.2.4. Calibration

To initiate the calibration process, tap on the pH or RX module line ("Module" in title) is between brackets. Once selected, the menu options will unfold, revealing a tab labeled "Calibration." Ensure you are prepared to remove the pH or RX probe from the installation and place it in the pH or RX calibration solution.

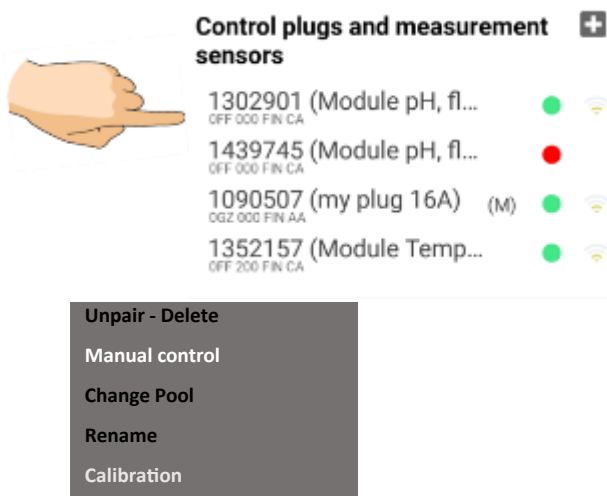

Follow the instructions on the screen to proceed with calibration.

3.1.2.5. Change Pool

3.2. Automation & Setting

With Gen 2, preprogrammed automations streamline the process by eliminating the need for manually adding automations check appendix 1 for extra info.

An automation makes the link between the measurements of a pool and a smart plug (or smart switch). Using the measurement results, we will start-stop a plug or smart switch. It is also possible to set up a timer and/or notifications in the automations

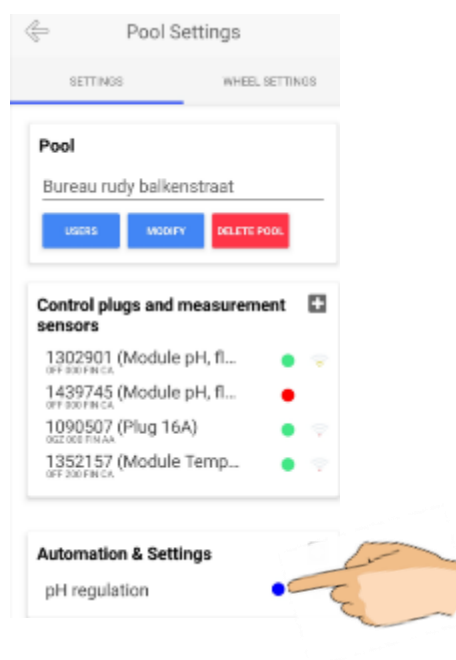

A blue circle behind the automation indicated the automation is not active because the target value has been reached, or because one of the conditions (e.g. a timer) stops the automation from running.

A green circle indicates the automation is running (e.g. pH pump is running).

The Wifipool automations have a feature called « duty cycle » .

A duty cycle of 30% / 60 seconds means that the power to the device being controlled will be on during 18 seconds each 60 seconds.

By enabling the duty cycle, it is possible to slow down the dosing of peristaltic pumps, enabling efficient water treatment in small volume pools and spas.

Attention:

The duty cycle parameter should not be adjusted by standard users. Altering this value can significantly disrupt the functionality and accuracy of your dosing device. Any modifications to these settings should only be performed by qualified personnel. Therefore, we strongly advise against making any changes to these parameters.

The Duty Cycle should never be used in combination with salt electrolysis or other pieces of equipment containing a control PCB.

The software is programmed with hysteresis. Hysteresis is a feature that helps prevent the device from switching on and off too frequently. Think of it like a buffer zone: it allows the device to wait for a small range before making adjustments, ensuring smoother and more stable operation. For example, in our system, the hysteresis for pH is set at 0.01, and for redox, it is set between at 10. This means the device will only make changes if the pH or redox levels move beyond these small ranges, preventing constant switching and ensuring accurate control.

3.2.1. Existing automation module

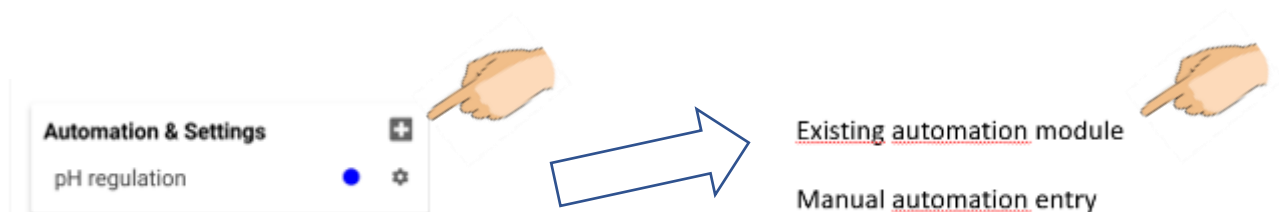

The existing automation module option allows the user to use a pre-defined automation module. The customer can choose between selecting a pre-defined automation or can scan a barcode from the manual joint to the product purchased.



Scanning the barcode or pressing the “Water treatment Liquid chlorine and acid for swimming pool, flow and level switch” link will have the same result : the full pre-defined automation will be installed on your swimming pool.

In this example, the regulation will be as follows :

pH and RX regulation (pH master)
 Daily Scheduler for water treatment between 9:30 and 17:30
 Notification sent to the phone if pH or RX is very high (>9) or low (<5.5) or no flow or low level.
 Safety stop if no flow or pH > 9 or RX >950 or level switch = low.

Appendix 1 gives an overview of the automation barcodes available.

The pre-defined automations contain all elements necessary to control correctly the equipment, including timers, notifications, safety stops if pool values deviate abnormally etc ...

We recommend to use a pre-defined automation and, if desired, adjust the values to your wishes. In the example below : press the « 7.6 » to modify the pH target value.

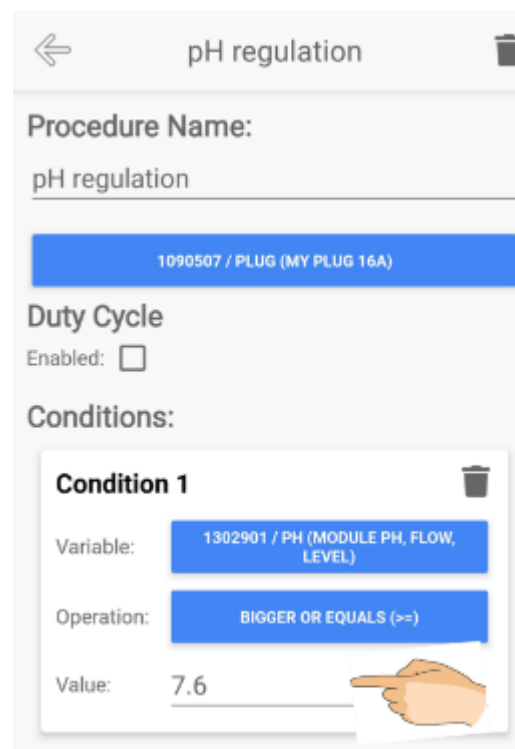

3.2.2. Manual automation entry

The automations can be entered manually as follows :

- Click on the **+** sign in the right corner, next to automations your pool settings tab which opens the “new procedure” page. Enter a name for you procedure

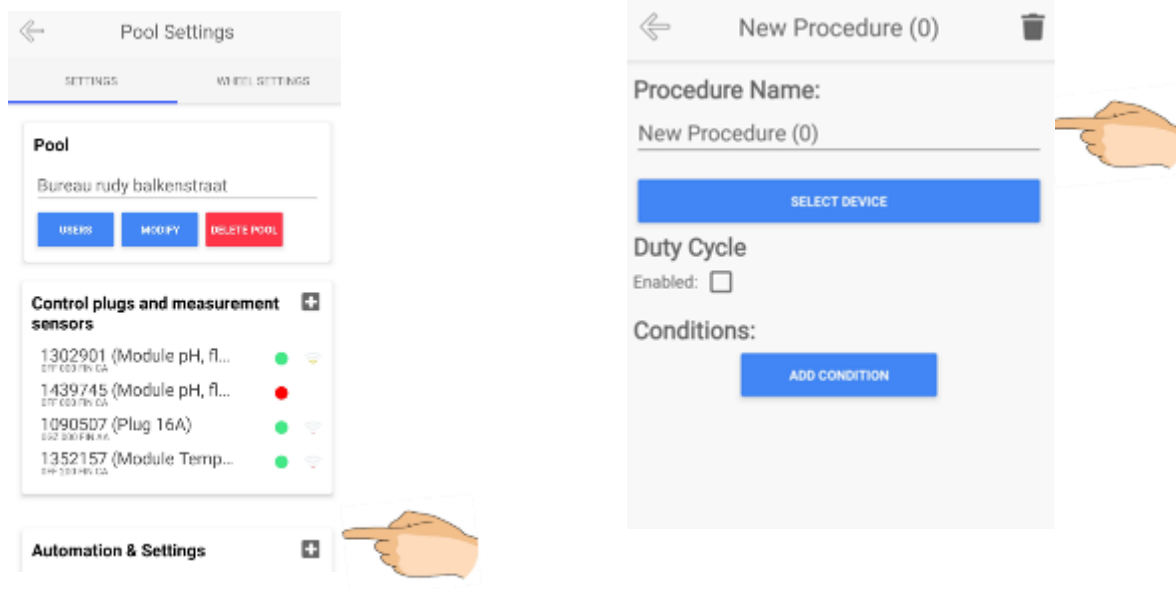

- Select the Wifipool device (plug , smart switch (or equipment containing a smart switch such as a peristaltic pump) you want to start and stop.

OR

- Select Push notifications to define de conditions under which you have to receive a notification.

In the example below, we create the procedure “pH control” by selecting our pH peristaltic pump as action device



- Define the condition

By pressing the “Add condition” button, we can select conditions at which the pH pump has to turn on. In our pH control example, we choose to start the pH pump (when the pH is larger or equal to (\geq)7.6 AND (by adding once again a condition) the flow switch detects flow.

In the example below, the pH pump will run only if $\text{pH} \geq 7.6$ AND the flow switch detects flow.

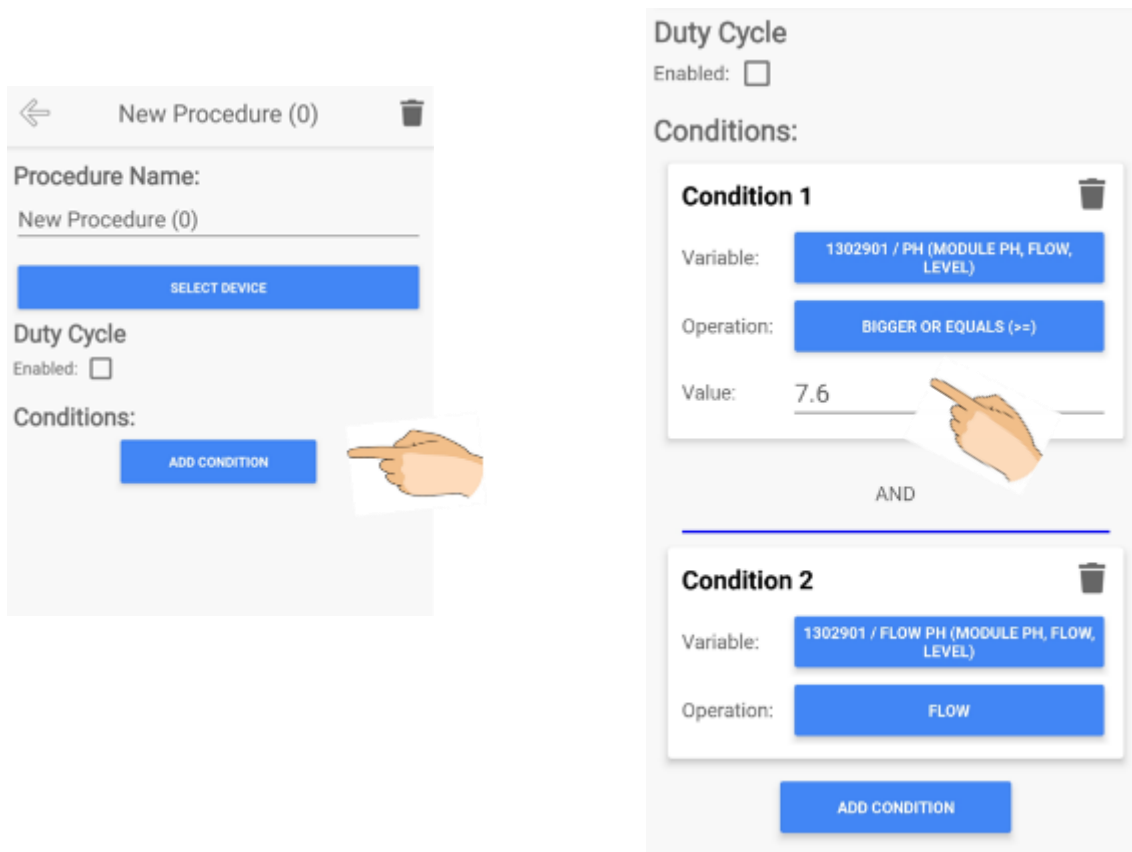

A unlimited number of conditions can be added

- Duty cycle:

With the duty cycle you are able to select the intensity for your device (output) to run on.
For example: Duty cycle % 30 Period (s) 60

This means that during the period of 60 seconds your device will run for 18sec in total (30% of the interval)

Click on enabled if you would like to use the duty cycle and in the values for your desired duty cycle

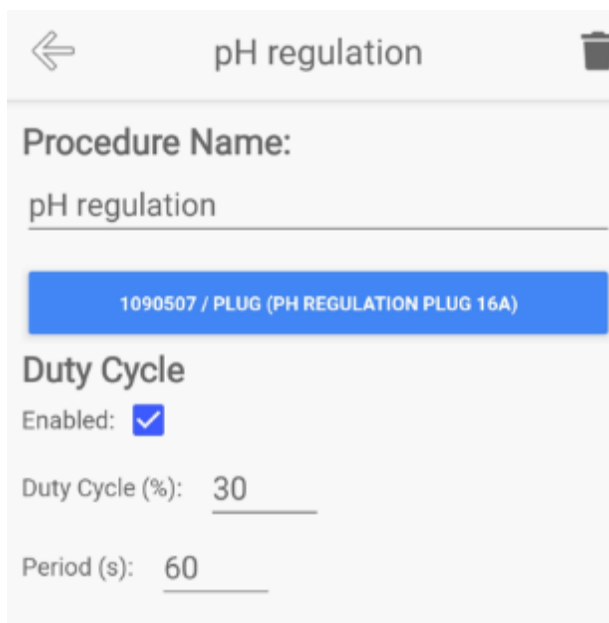

← pH regulation 🗑️

Procedure Name:
pH regulation

1090507 / PLUG (PH REGULATION PLUG 16A)

Duty Cycle
Enabled:

Duty Cycle (%): 30

Period (s): 60

In our example , the pH pump will run 30% of 60 seconds (= 18 secondes) per minute IF the pH > 7.6 AND flow is detected.

The duty cycle is typically used to reduce the dosing speed of peristaltic pumps.

Attention : never use the duty cycle with instruments which start up via a control PCB such as a salt electrolysis, frequency regulator, heat pump etcThe duty cycle will cause the instrument to switch on and off very frequently. This may cause electroic failure.

- Timer - scheduler

When selecting a condition, “Scheduler” is a option. When selecting the scheduler, a weekly schedule can be filled in.

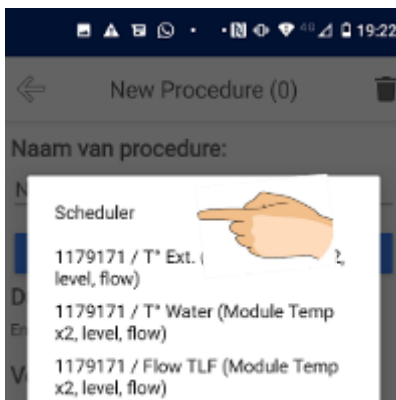

A weekly schedule will open, in which different time slots per day can be programmed

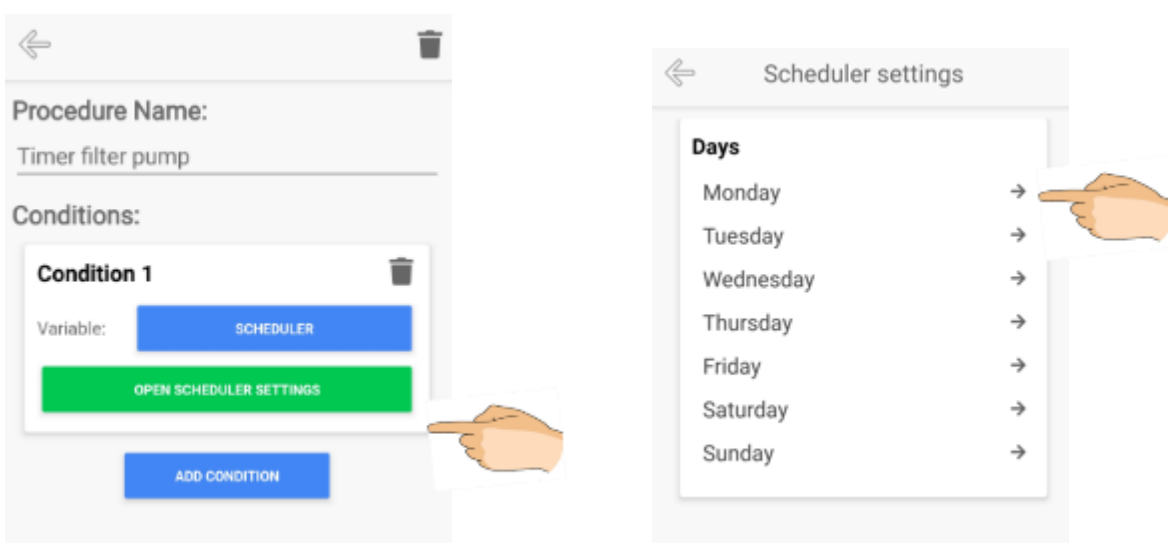

A alternative option for the scheduler, is to define a scheduler within the Snippets, and then selecting the Snippet as a condition. This has the advantage that the same timer can be used for several plugs / smart swtichtes.

3.3. Snippets

Snippets are “schedulers » which repeat themselves in several automations. As an example : the „Filter pump scheduler“, can be used for the filter pump as well as for the UV lamp plug.

Activate the Snippets by pressing the + sign, and complete and save the snippet just as described above in the “timer“ section

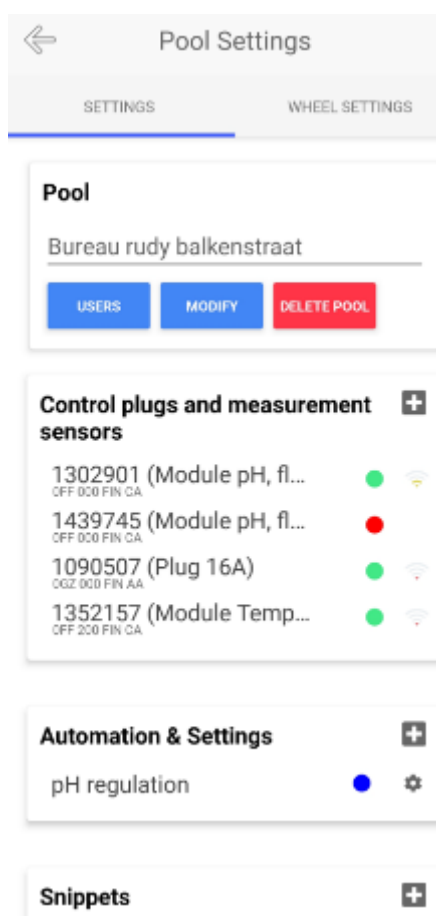

3.4. Notification scheduler

Adding a notification schedule

1. Scroll down to snippets. And press the plus icon. This will add a new snippet. Press the new snippet and change the “Procedure name” to something more appropriate (e.g. Notification scheduler). And press “Add condition”.

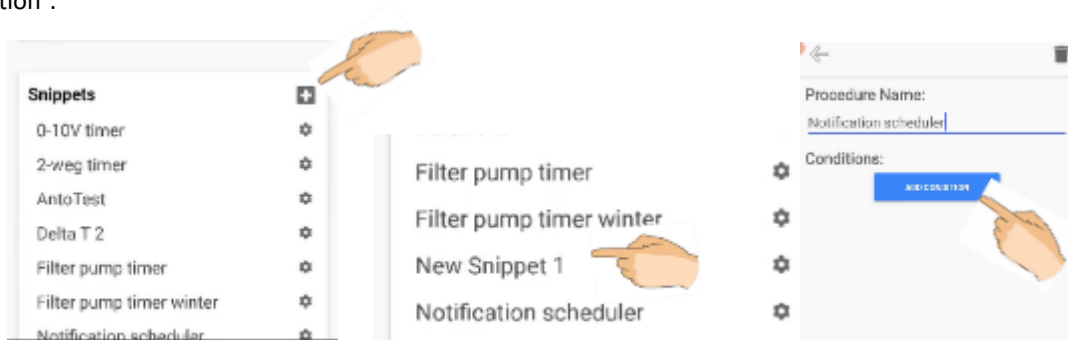

2. In the newly added condition just press “Select measurement”. All the way on top you’ll see an option with “Schedule” just select this.

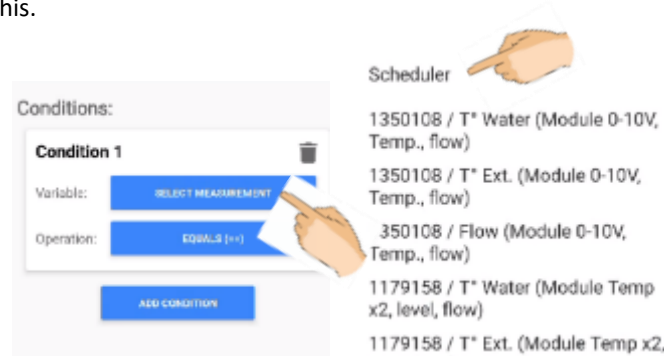

3. You can open the schedule settings now by pressing “Open schedule settings”. All days of the week will be displayed. Open for example Monday, and tab “add more” to add a new interval.

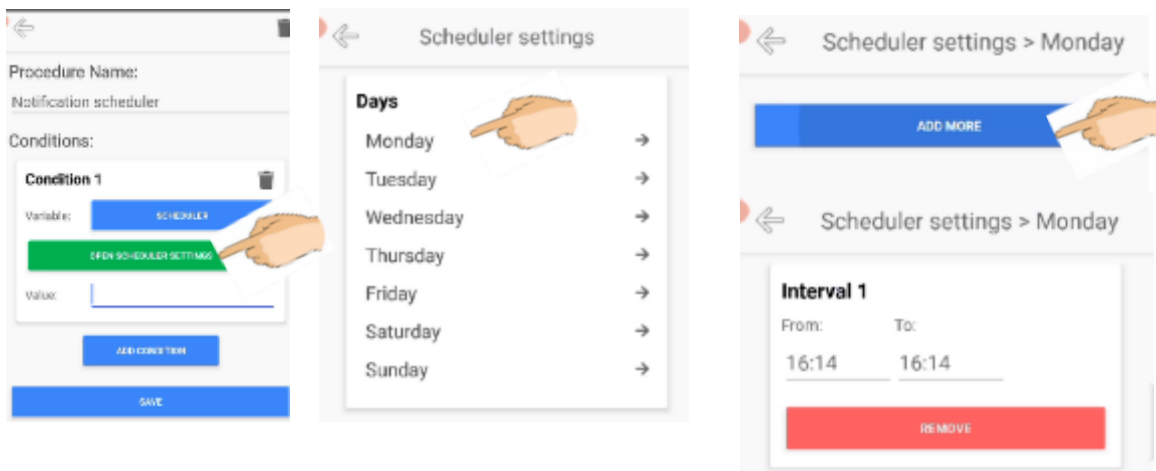

4. Modify the interval time “from” (when to start your operation) and “to” (when to stop your operation). E.g. 10:00 to 16:00. You have to manually change this for each day of the week. And press “OK”.

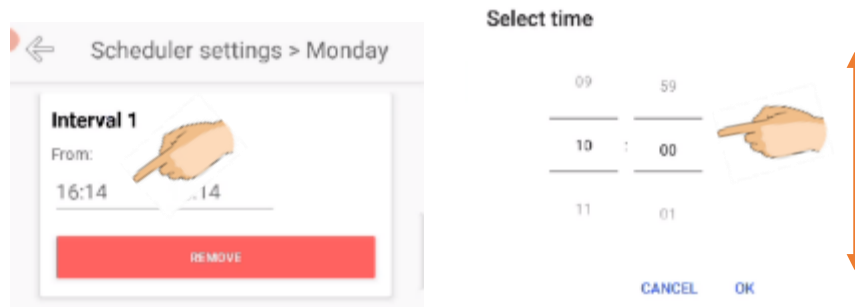

5. Once that's complete just navigate back to your Procedure settings and press save. After that you can go back to your pool settings and follow the instructions below to add an alarm notification.

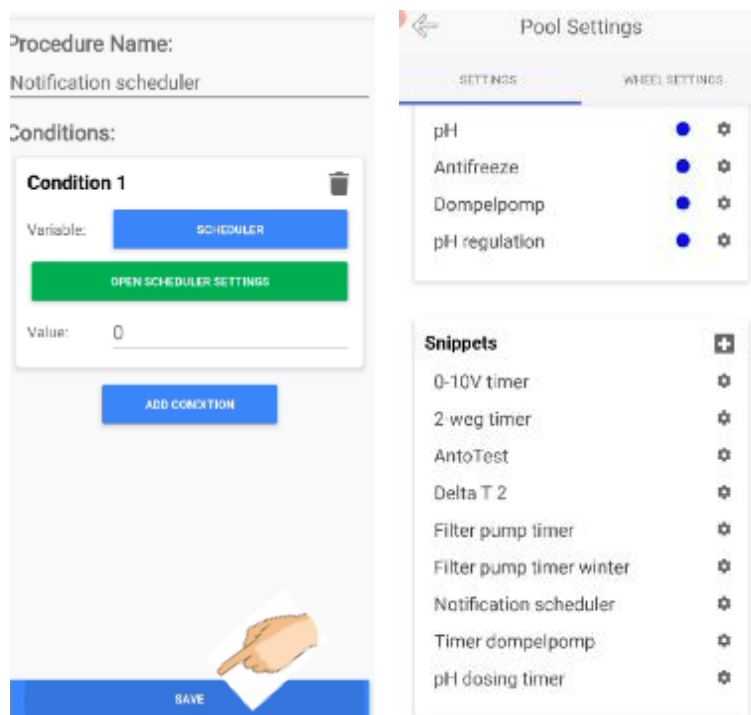

Adding alarm notification.

Make sure you also add an alarm notification in the manually entry itself.

6. In automations press the plus icon tab manual automation entry. Change the procedure name (e.g. pH > 9 alarm) and press “select device”.

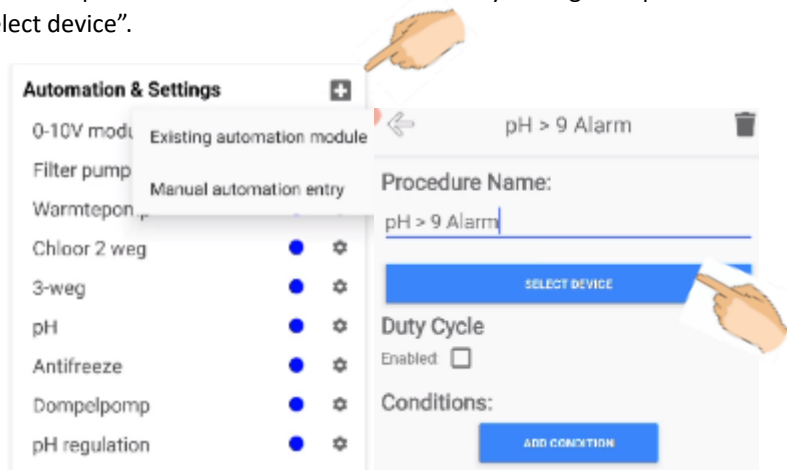

7. In select open “Alarm notification”. And change alarm message (e.g. pH > 9). Make sure to tab “add condition” and select, for example, your pH module.

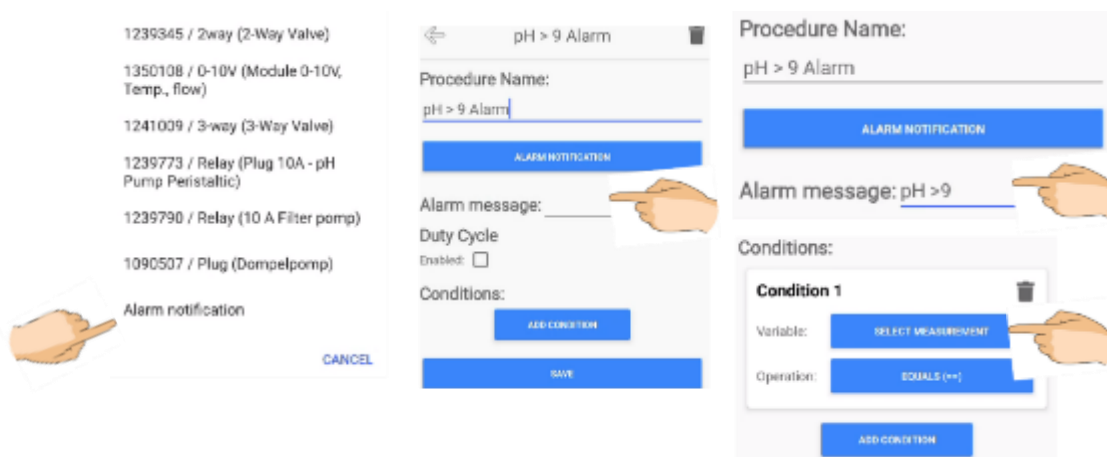

8. In here you can modify your operation and value.

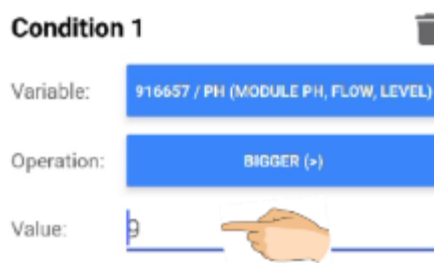

9. Finally press save.

3.5. Wheel Setting

Via the wheel setting page, you will be able to modify how the wheel on the main page looks like. You can choose icons, change the order, decide what you see and don't see in the wheel.

Via the wheel page, you can access the graphs pages.

As a special feature, you will be able to set the « fail safe » of your action devices.

You can access the wheel settings page via 2 routes :

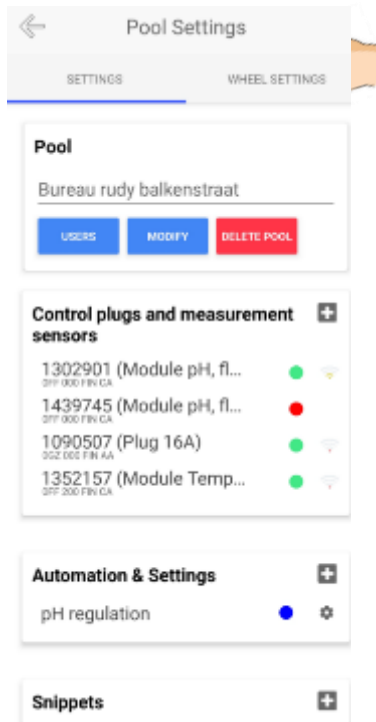

On Android phones

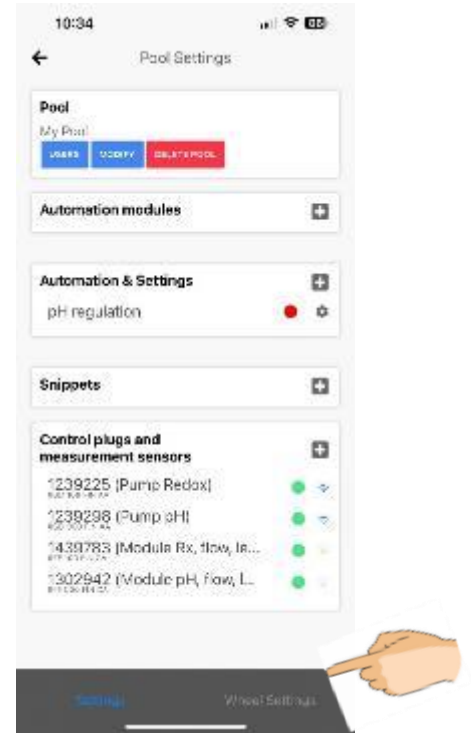

On iPhones

In the wheel, 3 variables are visible. By tapping the arrows, you can scroll through the pool variables displayed on the wheel. By tapping the graph symbol, you will see the graphical display of the last hour / 24H/3 days / week.

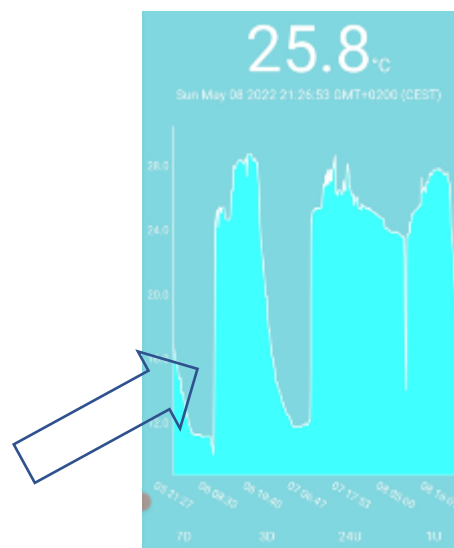
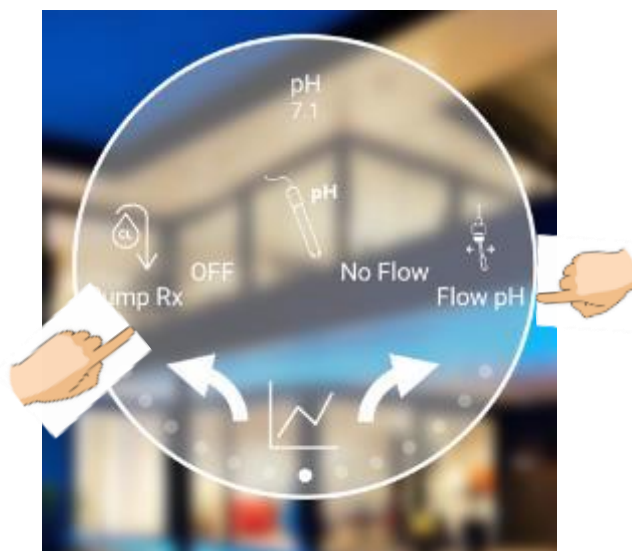

3.5.1. Wheel editing

Drag the items you want to make visible on your wheel dashboard from not visible to visible, by grabbing and dragging the 3 thin lines (sometimes you will need to hold your finger 3 seconds before dragging) at the right corner of your device. Make the reverse operation to make “invisible” items visible.

Moving items up or down within the visible zone, will change the order in which the devices are displayed on the wheel

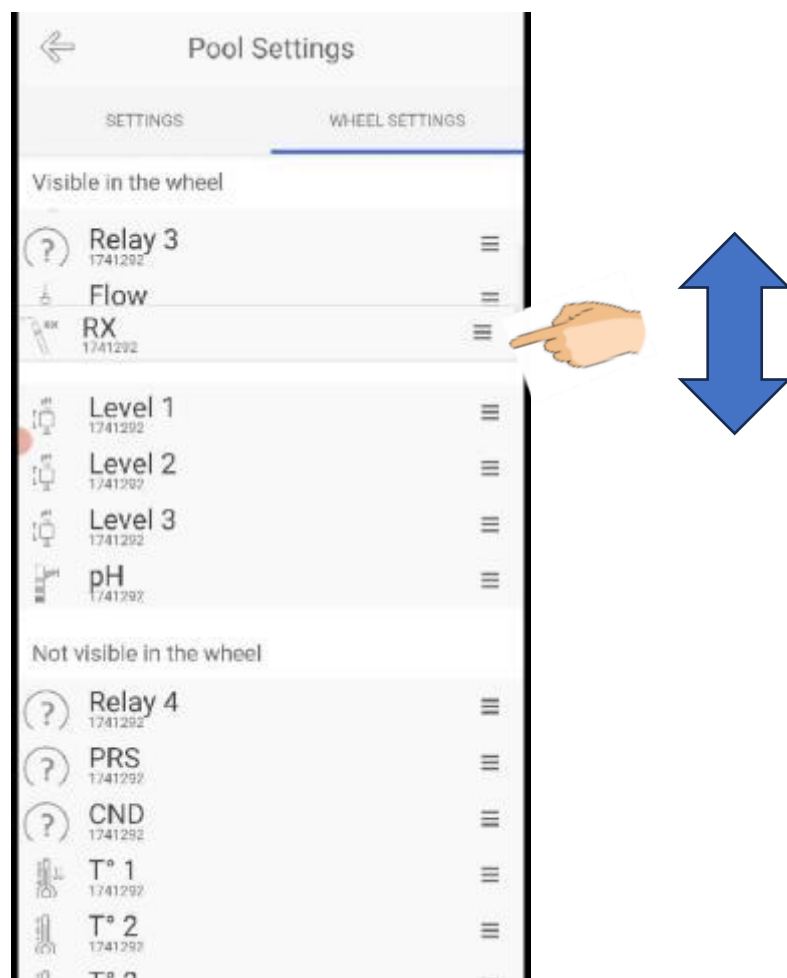

3.5.2. Icon selection

Tap on the device name in the “Wheel setting” page.

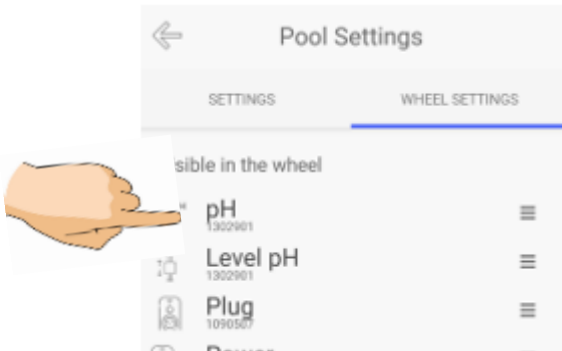

Select your favorite icon for your device. Go back by clicking on the top left corner arrow

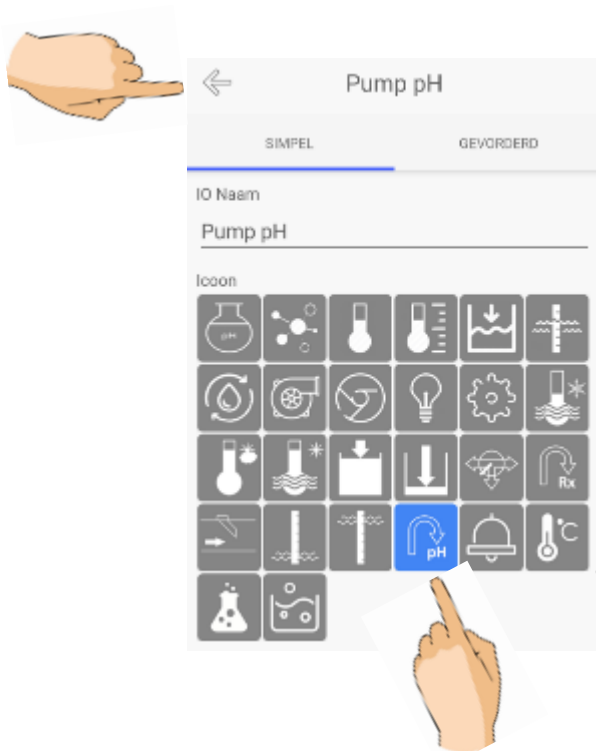

3.5.3. Failsafe mode

The Failsafe mode is used to define, what the device has to do in case wifi (or other) connection is lost : stop working or continue to work.

The failsafe mode can only be set for “action devices” such as plugs ,smart switches, pumps and automatic valves and not for measurement boxes.

To enter the failsafe menu, tap on the name of the device name once, followed by “advanced”.

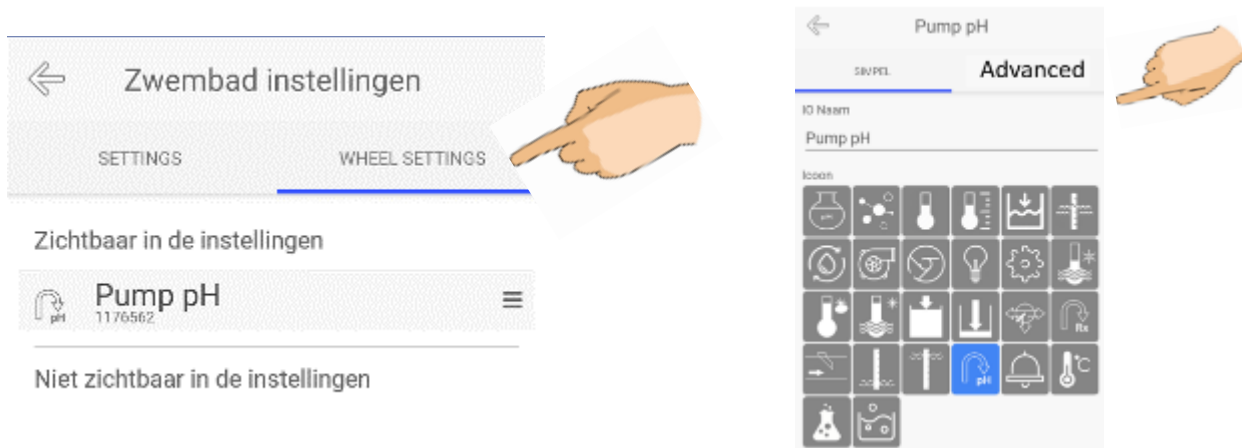

On the safety mode page, we can enter value 0 or 1.



At a failsafe setting of 0, the plug or smart switch will turn OFF during a system failure (e.g., loss of Wi-Fi). This setting is suitable for devices like a pH peristaltic pump. During a Wi-Fi loss, the pump needs to stop pumping.

At a failsafe setting of 1, the plug or smart switch will turn ON during a system failure (e.g., loss of Wi-Fi). This setting is appropriate for a winterizing filter pump, programmed to operate when outside temperatures drop below 2°C. If Wi-Fi is lost, the pump needs to continue running to prevent freezing.

Caution = be aware of the risk when switching failsafe on or off.

Example: set the pH dosing pump to failsafe 1, can cause pH- to be pumped nonstop to your swimming pool when internet connection is lost

The failsafe mode can only be set for “action devices” such as plugs ,smart switches, pumps and automatic valves and not for measurement boxes.

3.6. Action devices : Plugs and switches

Gen 2

In gen 2, there are no plugs or switches bur relays built right into the device itself. The Gen 2 connects straight to its power supply, as well as the pH pump and RX pump, making everything simple and straightforward.

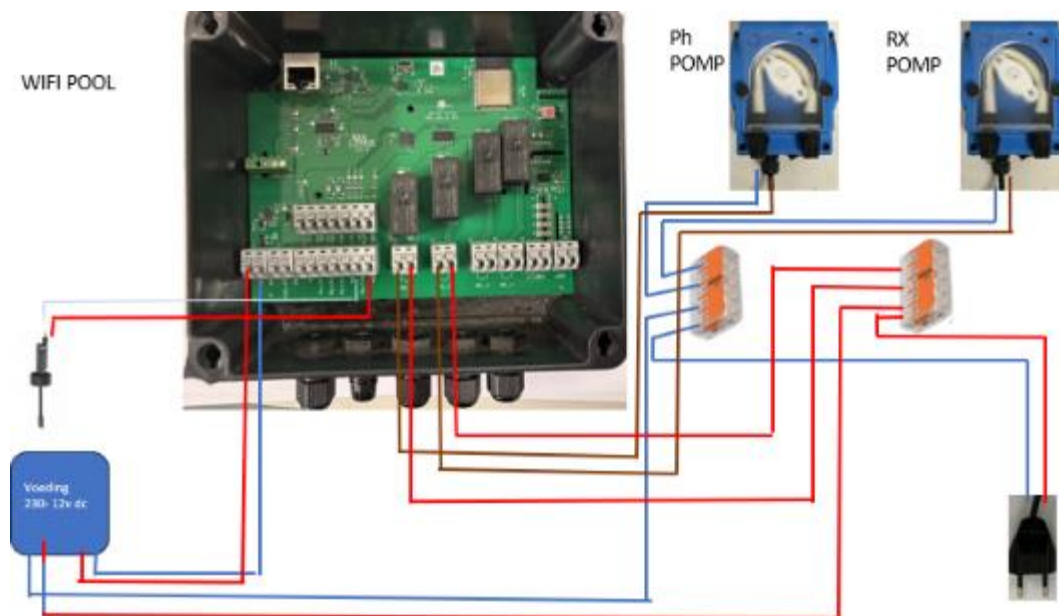

Gen 1:

Action devices, are devices with which you can start, stop, activate or deactivate a piece of equipment.

The Wifipool products are compatible with Shelly action devices, but only when the Wifipool software has been injected in the shelly devices

3.6.1. Plugs



Control plug 16A



Control plug 10A

The plugs operate on 230V

These plugs and switches will allow a pool equipment, such as a filter pump, UV lamp, peristaltic pump etc. to switch on or off. They are excellent for retrofitting existing equipment (such as a filter pump, peristaltic pump, lighting etc.) in the Wifipool app.

The plugs measure the power consumed.

3.6.2. Smart switches



Smart switch 16A



Smart switch 16A



Smart switch Plus 2 PM

Depending on the smart switch, they operate on 12, 24 and/or 230V.

These switches will allow pool equipment, such as a filter pump, UV lamp, peristaltic pump etc. to switch on or off. The Shelly smart switch 2 PM is used to switch a piece of equipment (e.g. an automatic valve) between position A and B. In some cases you will find these switches “hidden” in the Wifipool equipment.

Only the “red” smart switch; measures the consumed power.

The smart switches need to be connected to the pool equipment as follows :

Connection with on-off switch
For smart plug ZWPX0010

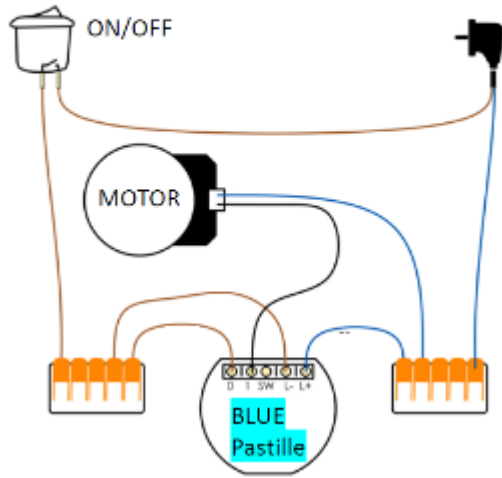

Connection without on-off switch
For smart plug ZWPX0010

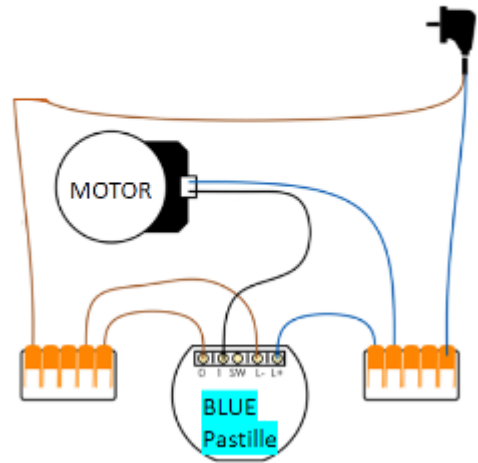

Connection with on-off switch
For smart plug ZWPX0020

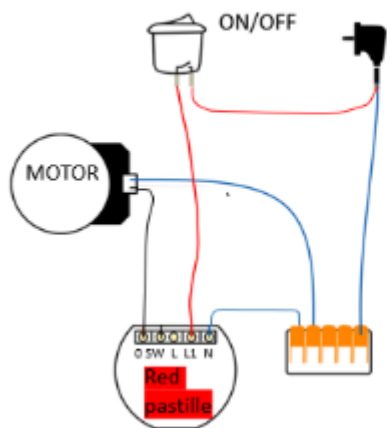

Connection without on-off switch
For smart plug ZWPX0020

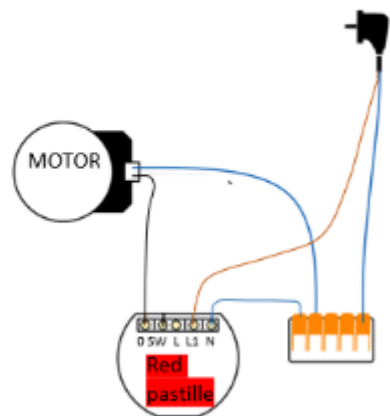

Equipment dependant
open/close connections

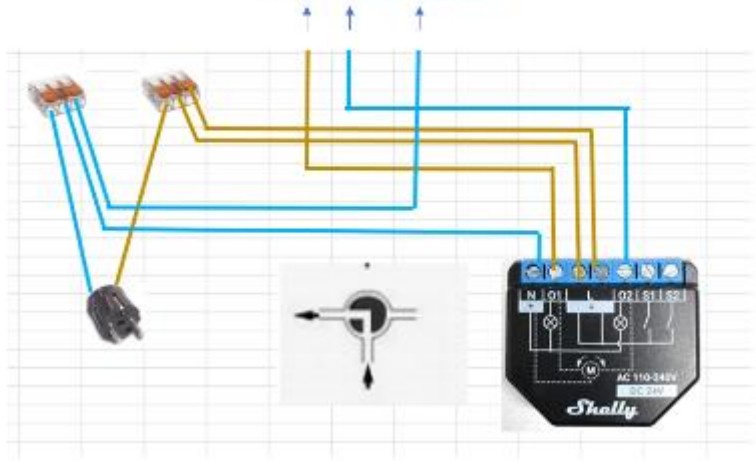

For the Shelly 2PM module,
the exact wiring depends on
the specific product.

3.7. Measurement devices

3.7.1. pH, RX and Temp

Our system contains 3 measurement boxes



pH, level, flow



Redox, level, flow



Temperature (x2), level, flow (TLF)

The units operate on a 5V USB plug, and consume less than 1 Amp.

The pH and RX probes have a regular and standard BNC connection

Level switch, flow switch and temperature probes have a male/female 3 or 2 pole water-tight Higo connection which are color coded so no mistake is possible.

These measurement boxes will allow you to measure various pool characteristics, which will be displayed on the mobile phone. Via the automation menu, it will be possible to steer the plugs and smart switches, depending on the measurements.

When adding a new measurement (flow or level switch) : disconnect the measurement box from the power, plug in the sensor, and connect to the power while the sensor is off position (no flow, low level)

For the temperature measurement box, it is necessary to plug in the measurement probes, before connecting the box to the power. If you see that the outside temperature and water temperature are "switched", then unplug the temp unit from the power, switch the temperature probes and plug the temp module into the power.

3.7.2. Combined measurement and control devices

3.7.2.1. 0-10V and 4-20mA

The 0-10V and 4-20mA modules contains both a “action” part and a “measurement part”

The modules can emit a constant voltage between 0 and 10V, or a constant current between 4 and 20mA. The modules can be used to control a external device.

The frequency regulator is controlled by applying a voltage to the regulator, where 0V = 0 rpm and 10V = 2950 rpm.



Both modules have one flow and two temperature measurement connections.

3.7.2.2. All-in Gen 2 – 2024

In gen 2 there are no more plugs and switches to worry about. Now, everything you need is built right into the device itself.



In a Gen 2 equipment , there are following measurements :
pH, RX, temperature (x3), level (x2), flow, pressure and conductivity (salt content).

There are 4 relays which can control 12-240V powered devices.

Additionally, Gen 2 introduces new connectivity options. Alongside Wi-Fi pairing, there's now Ethernet pairing available. While Wi-Fi is an option, it's important to note that the company prefers Ethernet connections. In the event of Wi-Fi issues, users may be subject to charges, so it's recommended to utilize Ethernet for optimal performance.

Not only is Gen 2 more connected, but it's also quicker to install. In previous generations, users had to scan each module separately during setup. However, with Gen 2, only one barcode needs to be scanned, and it's ready to go. This streamlined process minimizes installation time and hassle, getting users up and running faster than ever before.

Moreover, Gen 2 comes equipped with preprogrammed automations, further enhancing its user-friendly nature. These built-in automations simplify tasks and workflows, providing added convenience and efficiency for users. With Gen 2, automation is at your fingertips, ready to streamline operations and maximize productivity.

4 Problem Solving

4.1 Resetting your Wi-Fi equipment

After a “miscommunication” between cloud and device, it may be necessary to reset your device. To reset your smart plug you have to follow the Reset Procedure.

Gen 2:

To reset your Gen 2 WiFiPool device, please follow these detailed steps:

1. Open the Lid: Start by carefully opening the lid of your WiFiPool device. This will give you access to the internal components.
2. Locate the Red Button on the PCB: Once the lid is open, locate the red reset button on the printed circuit board (PCB). It is essential to identify this button correctly to proceed with the reset process.

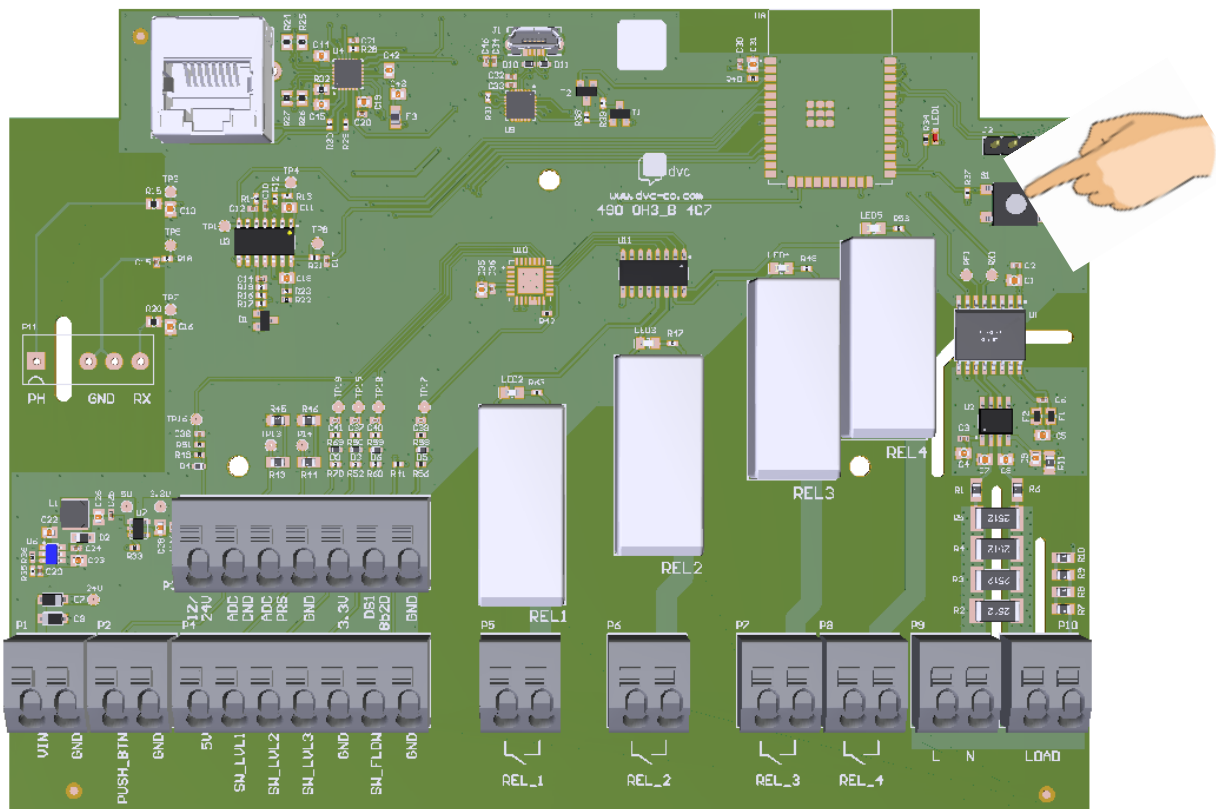

3. Hold the Reset Button: Press and hold the red reset button for exactly 40 seconds. Use a timer or a stopwatch to ensure that you hold the button for the full duration. Timing this step accurately is crucial for a successful reset.
4. Verify the Reset: After holding the reset button for 40 seconds, release it and observe the device. The reset process should now be complete.
5. By following these steps, your WiFiPool device should be successfully reset and ready for use.

Gen 1:

- Plug your smart plug in the outlet
- Plug out the USB for 10 sec
- Plug in-out the plug 7x

1. Plug your USB briefly in (1sec) and then pull out your USB for 2 Sec
2. Plug your USB briefly in (1sec) and then pull out your USB for 2 Sec
3. Plug your USB briefly in (1sec) and then pull out your USB for 2 Sec
4. Plug your USB briefly in (1sec) and then pull out your USB for 2 Sec
5. Plug your USB briefly in (1sec) and then pull out your USB for 2 Sec
6. Plug your USB briefly in (1sec) and then pull out your USB for 2 Sec
7. Plug your USB in and leave it in on the 7th time



Repeat 7 X



The same procedure applies also for the smart plug



Repeat 7 X



... procedure correctly than y... app and scan for devices : your phone will be searching for the plug.

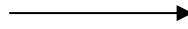
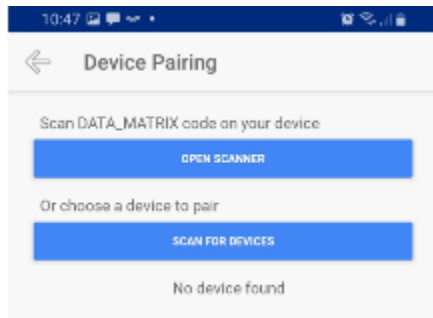

4.2 Notifications do not arrive consistently

On most devices, an app has background processes that allow it to do things like get notifications, which will remain active even when the app is closed.

Certain manufacturers (including OPPO & Xiaomi) have made their own versions of Android for their devices, so that notifications are not forwarded or only occasionally.

Fortunately, the settings that ensure that the app cannot forward notifications can be adjusted. The following article explains how you can make these adjustments for various devices (including of course OPPO) and thus hopefully receive the notifications as expected: <https://help.pushwoosh.com/hc/en-us/articles/360028478751-Android-device-cannot-receive-push-notifications-when-an-application-is-force-stopped-killed->

4.3 Pairing

Pairing problems have been addressed above

4.4 Contact troubleshooting

For troubleshooting, contact your supplier or contact info@beniferro.eu .

To make sure you can be helped efficiently, make sure info@beniferro.eu has become a user level co-owner of your pool (see section 3.1.1.2)

Appendices

Appendix 1: Preprogrammed Automations

In Gen 2, automations occur automatically after pairing your device. These are already set up by the system upon installation.

You can view the preprogrammed automations in "Automation & Settings". Most of these preprogrammed automations are based on conditions that work for most pools. Automations ensure that your modules are activated when certain conditions are met. For example, if your pH level is above 7.6, then your pH pump will start, or when there's flow or no flow, high or low redox levels, etc.

You can manually modify these automations or add your own. To modify the automations, tap on the automation title, and in the menu, you can adjust the conditions to your preferences. Only modify these settings if you understand what you're doing.

To create new automations, simply tap the plus icon and follow similar steps to modification as described in the previous paragraph.

For Gen 1 devices, preprogrammed automations exist but these need to be scanned in via a barcode. See the quick start manual of the device purchased.

Appendix 2 : Pairing instruction sheet example

Pairing and automation Wifipool water treatment

Thank you for choosing our Wifi water treatment. For an easy and quick start, we recommend the following:

1 Install the wifipool app. Instructions for installing the app can be found in the attached Wifipool App Quick Start Guide and Simple Equipment.

2 Pair the device with your phone

It's best to do this indoors in an area with a good Wi-Fi network connection (the same network you'll use for your pool) and a modem with a network cable connection (ethernet cable)

3 Connect the Wifipool control box to your modem via a network cable (ethernet cable) and start pairing. If you want to pair over a Wi-Fi connection (not recommended), refer to the Wifipool App Quick Start Guide and Simple Equipment. Please note: Beniferro does not provide free support for pairing via Wi-Fi, if you have a device with a network cable connection

3.1: Go to the "Pool Settings" app page,
tap on the plus icon next to
"Sockets & Measurement Sensors".

3.2: Select "Scan" and scan this
barcode:



3.3: Select the Wi-Fi network you want to use for your pool equipment

Once pairing is complete, you can continue with or without a network cable. Without a network cable, a good connection to your Wi-Fi network is required.

4 During pairing, automation was also loaded.

5 Once you've calibrated the pH and RX sensors, you're ready to use your device.

Appendix 3a : Gen 2 technical specifications

ETHERNET CONNECTION	Desired for pairing Possible for daily operation
STABLE WIFI	Required if ethernet cable is not available - standard extender or powerline compatible
WIFI CONNECTION PROTOCOL	802.11b, 802.11g and 802.11n
WI-FI RADIO FREQUENCY	2412 - 2484 MHz
WI-FI RADIO SIGNAL POWER	<1mW
WIFI DISTANCE OUTDOORS	up to 50 m outdoors and up to 30 m indoors (depending on the building materials)

PCB WITH ETHERNET CONNECTION – GEN 2	pH, RX measurement Extendible with Temperature measurement (x3), flow switch, level switch(x3), pressure measurement, conductivity measurement 4 ON-OFF relays 12-240V
TEMPERATURE SPECIFICATION	-20°C to + 70°C
CONFIGURATION	Via mobile phone (preconfigured)
AVAILABLE LANGUAGES	NL, EN, FR, DE, IT, ES
RELAY CONTROL	12-240V
POWER SUPPLY	12-240V(relai) 12 or 24V (PCB power)

Appendix 3 b : Gen 1 technical specifications

STABLE WIFI	Required - standard extender or powerline compatible
WIFI CONNECTION PROTOCOL	802.11b, 802.11g and 802.11n
WI-FI RADIO FREQUENCY	2412 - 2484 MHz

WI-FI RADIO SIGNAL POWER	<1mW
WIFI DISTANCE OUTDOORS	up to 50 m outdoors and up to 30 m indoors (depending on the building materials)

TEMPERATURE SPECIFICATION	-20°C to + 70°C
CONFIGURATION	Via mobile phone (preconfigured)
AVAILABLE LANGUAGES	NL, EN, FR, DE, IT, ES

ETHERNET CONNECTION	Desired for pairing Possible for daily operation
STABLE WIFI	Required if ethernet cable is not available - standard extender or powerline compatible
WIFI CONNECTION PROTOCOL	802.11b, 802.11g and 802.11n
WI-FI RADIO FREQUENCY	2412 - 2484 MHz
WI-FI RADIO SIGNAL POWER	<1mW
WIFI DISTANCE OUTDOORS	up to 50 m outdoors and up to 30 m indoors (depending on the building materials)

PCB WITH ETHERNET CONNECTION – GEN 2	pH, RX measurement Extendible with Temperature measurement (x3), flow switch, level switch(x3), pressure measurement, conductivity measurement 4 ON-OFF relays 12-240V
TEMPERATURE SPECIFICATION	-20°C to + 70°C
CONFIGURATION	Via mobile phone (preconfigured)
AVAILABLE LANGUAGES	NL, EN, FR, DE, IT, ES
RELAY CONTROL	12-240V
POWER SUPPLY	12-240V(relai)

12 or 24V (PCB power)



BENIFERRO.eu
plug & play products

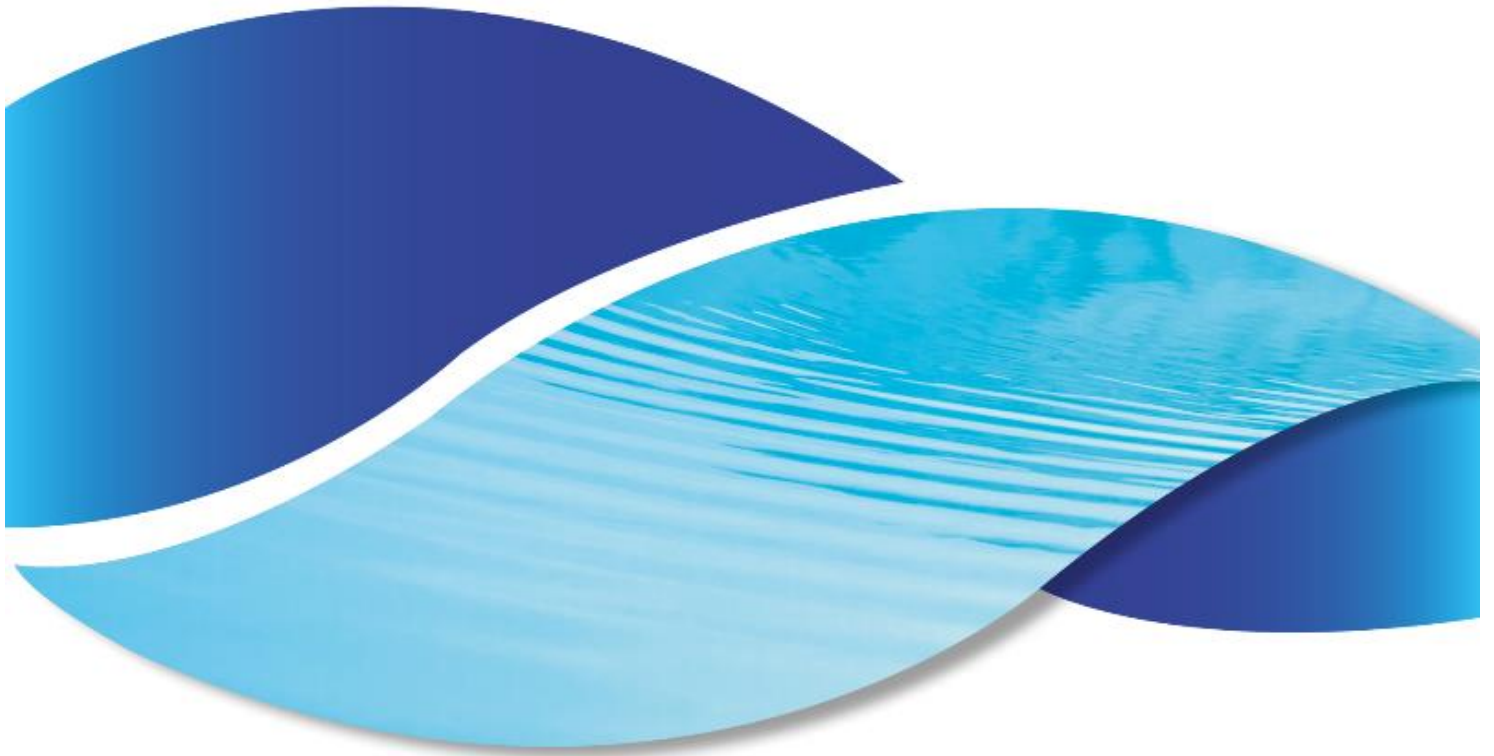

Wifipool App and Simple Devices – full manual



Contents

Introduction

1. The Wifipool app.....
 - 1.1. Introduction
 - 1.2. Installation of the app
 - 1.3. Changing your password, profile and privacy settings
 - 1.4. 1.4 Log out
- 2 Pairing.....
 - 2.1 What is pairing.....
 - 2.2 Problems with pairing.....
 - 2.3 Before pairing.....
 - 2.4 Pairing via ethernet connection.....
 - 2.5 Pairing via website.....
 - 2.6 Pairing via smartphone for IOS.....
 - 2.7 Pairing via smartphone of for Android.....
 - 2.8 Pairing trouble shooting.....
- 3 Using the Wifipool app.....
 - 3.1 Pool Settings
 - 3.1.1 Pool
 - 3.1.2 Control plugs and measurements
 - 3.1.3 Unpair
 - 3.1.4 Rename
 - 3.1.5 Calibration
 - 3.2 Automation & Setting
 - 3.2.1 Existing automation module
 - 3.2.2 Manual automation entry
 - 3.3 Snippets
 - 3.4 Wheel settings
 - 3.4.1 Wheel editing
 - 3.4.2 Icon selection
 - 3.4.3 Fail safe
 - 3.5 Action devices : Plugs and switches
 - 3.5.1 Plugs
 - 3.5.2 Switches
 - 3.6 Measurement devices
 - 3.6.1 pH
 - 3.6.2 RX
 - 3.6.3 Temp
 - 3.6.4 Control devices
 - 3.6.5 0-10V

3.6.6 Combined measurement and action devices

3.6.6.1 0-10V

3.6.6.2 All-in Gen 2 – 2024

4 Problem Solving

5 Appendices

5.1 Appendix 1 : automation barcodes

5.2 Appendix 2 : automation details

5.3 Technical specifications

Introduction:

The "Wifipool" app can be used to monitor and control your pool using the Wifipool Connect Pro Measurement and Control Box, smart plugs, and various sensors such as pH, Redox, and Temperature, along with associated accessories such as pH probes and temperature sensors.

To install and use the measurement and control box, you need to follow a series of steps:

- 1 Installing the Wifipool App
- 2 Connecting the Measurement and Control Box to the Wi-Fi Network and Phone
- 3 pH and RX calibration (if applicable) & automation



After completing these three steps, your device will be operational.

This manual describes the installation and use of the Wifipool app (step 1) and explains basic hardware functions (step 2)

The detailed specific operation of Wifipool filter pumps, water treatment modules, calibration and heating equipment are explained in the device manuals.

With Wifipool, it is possible to truly use one app for the control of your swimming pool.

We hope the product will contribute to a perfect pool control experience and great swimming pool pleasure

The Wifipool Team

1. The Wifipool app.

1.1.Introduction

The "Wifipool" app can be used to control your pool using the Wi-Fi pool measuring devices for pH and Redox, in combination with the Wi-Fi pool control devices such as smart plugs / smart switches, peristaltic pumps, and salt electrolysis.

The main page of the app features a wheel interface, displaying measurement values such as temperature, pH, etc. Swiping left or right on the wheel enables users to switch between multiple pools or create additional ones. **1** Tapping in the middle of the wheel or on the arrows allows users to toggle between different parameters of the selected pool, such as pH value, temperature, etc. **2** Tapping on the pool name redirects users to the pool's settings menu. **3** Selecting 'Edit Wheel' permits users to modify the content and order of the values displayed in the wheel.

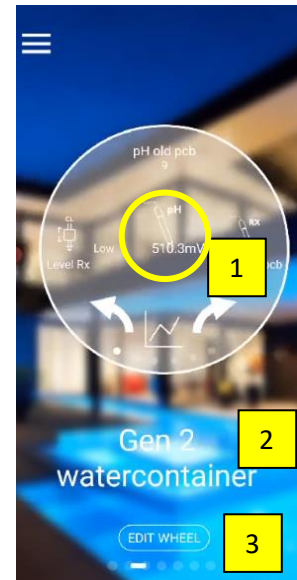

On the initial screen, **1** users can observe the status of your current value, whether it is on or off. Additionally, **2** there is a button for accessing statistics. Tapping the statistics button reveals how the current values are changing over time. **3** Two arrows, pointing left and right, facilitate navigation through the various pages. These pages include sections for pH, Rx, pH flow, and Rx flow.

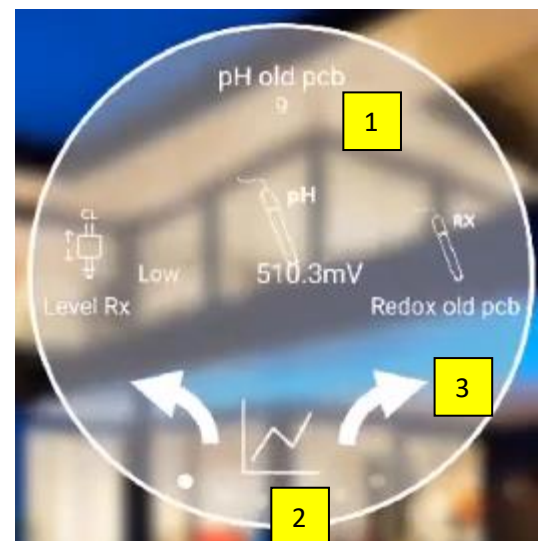

In addition to the Wifipool app, you need measuring boxes with accessories (probes, sensors etc.) to measure and display the pH, Redox, temperature etc. and smart plugs or other Wi-Fi pool control devices to turn your equipment on or off.



Before being able to use the app, you will need to install it. Then, you'll need to pair the Wifipool devices with your home Wi-Fi network and your phone. Finally, you will need to install the automations.

There are two versions of the Wifipool device: Gen 1 and, as of 2024, Gen 2. Gen 2 combines measuring and control devices on one PCB. Gen 1 operates via Wifi,, Gen 2 devices operate via Wifi and ethernet.





To connect the device, you first need to pair it to your phone and home network. Pairing via a ethernet cable is significantly more rapid and easier than pairing over Wifi.



1.2. Installation of the Wifipool application

1.2.1 Download the app

Android

1.  Go to the Google Play Store on your mobile device.
2.  Search for Wifipool
3. Click Download
4. Open the app and tab on the “Create one!” link. This will enable you to create an account. If you already have an account, you are not required to do so again. Continue following the instructions.

IOS (Apple)

1.  Go to the App Store on your mobile device.
2.  Search for Wifipool
3. Click Get
3. Open the app and tab on the “Create one!” link. This will enable you to create an account. If you already have an account, you are not required to do so again. Continue following the instructions.

1.2.2 Creating Wifipool Account

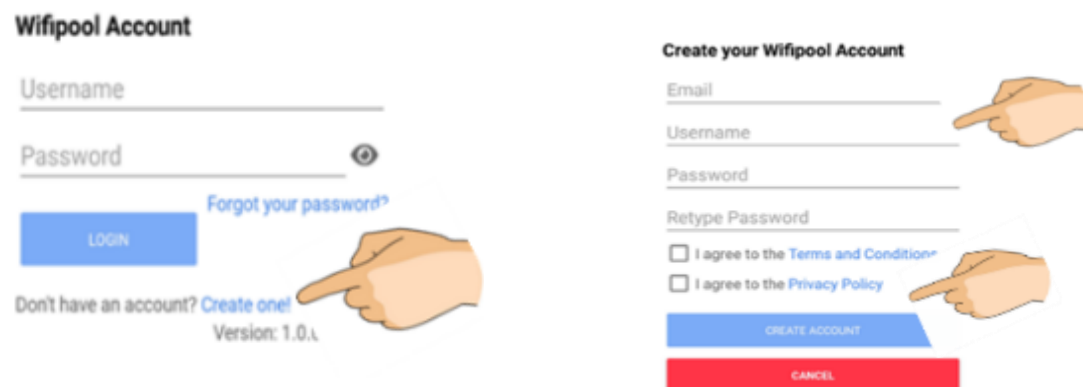

Wifipool Account

Username _____

Password _____ 

[Forgot your password?](#)

LOGIN

Don't have an account? [Create one!](#)

Version: 1.0.1

Create your Wifipool Account

Email _____

Username _____

Password _____

Retype Password _____

I agree to the [Terms and Condition](#)

I agree to the [Privacy Policy](#)

CREATE ACCOUNT

CANCEL

4. Enter your personal details and consent to the terms and conditions as well as the Privacy Policy to create a Wifipool account.
5. Press create account. The app will then send a verification email to your email address.
6. Proceed to your personal email account to confirm your email address. Check your 'spam' folder, as the email may end up there. If you haven't received an email, there might be a typing error in the email address or password. Consider trying to create the account again

1.2.3 Checking Wifipool version

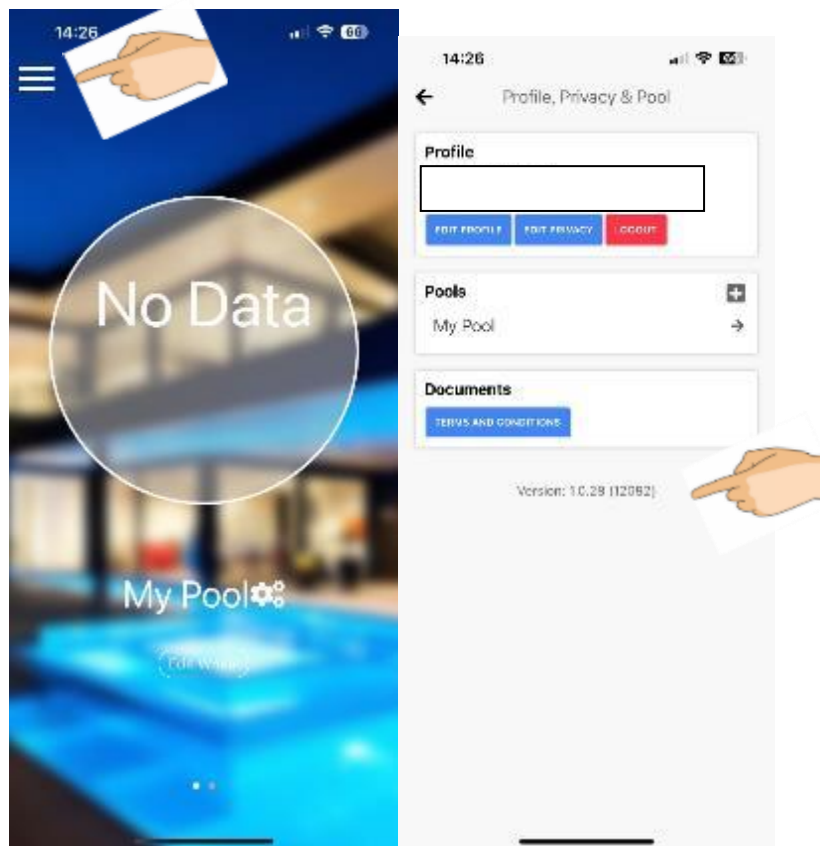

1. Always ensure you have the latest version of the app.
2. To do so, press \equiv in the top right corner of your screen.
3. This action will open the Profile, Privacy & Pool settings.
4. At the bottom of this screen, you will find the current version of the app.

Please note: The version displayed in the photo may not be the latest version of the app. Do not be alarmed if your version happens to be newer.

1.3.Changing your password, profile and privacy settings

Edit Profile and password

1. Click on the top left corner to go to the open the navigation bar and tab "Edit profile, privacy, logout".

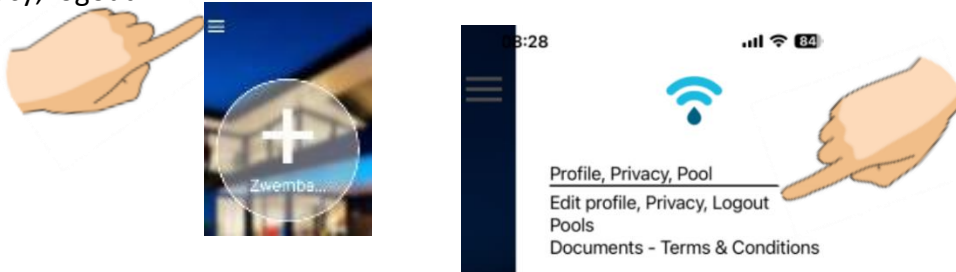

2. Click "Edit Profile"

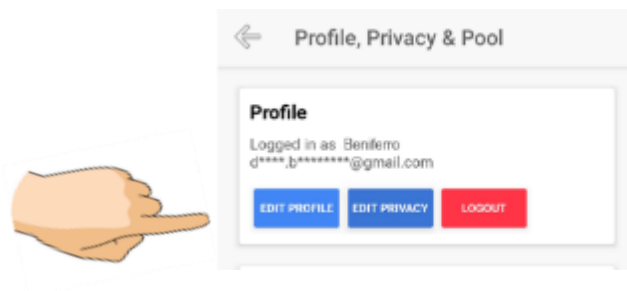

- 3 Change your personal information

- 4 Scroll down and click "Update" to confirm your changes

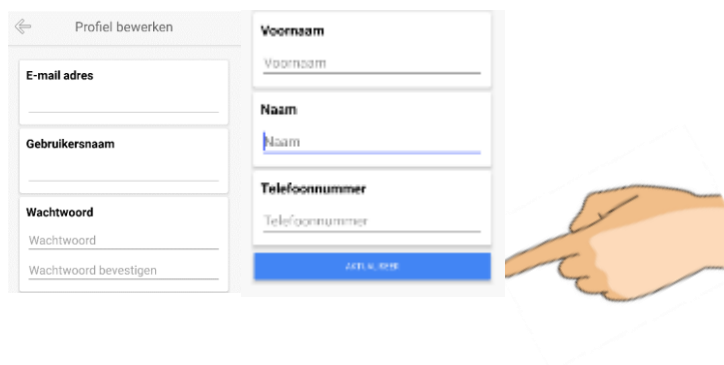

Privacy settings

1. Click on the top left corner to go to the open the navigation bar and tab “Edit profile, privacy, logout”.
2. Click "Edit Privacy"

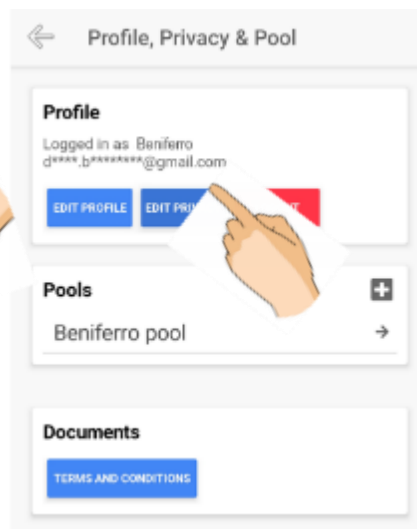
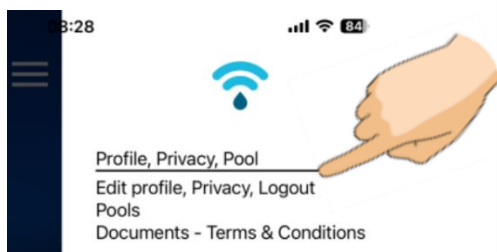
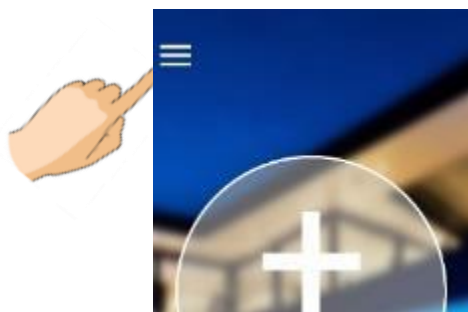

3. You can adjust your privacy settings by toggling the checkboxes.
4. Scroll down and click "Update" to confirm your changes



Please note: The above privacy settings may not display the complete list. They might not reflect the latest version. For the most up-to-date privacy settings, refer to the settings available on your phone.

1.4. Log out

1. Click on the top left corner to go to Profile, Privacy and Pool
2. Click "logout"

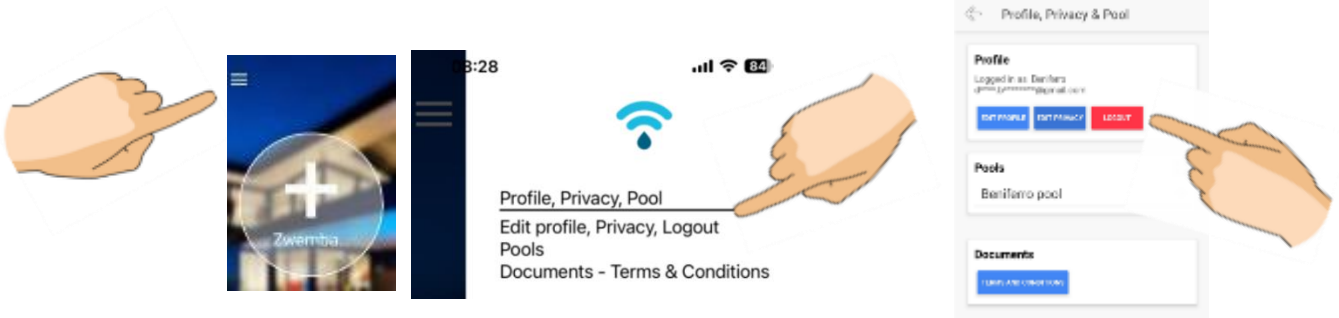

2 Pairing

2.1. What is pairing ?

Each Wifipool device emit a Wi-Fi signal. During the pairing process, we establish a connection between the Wi-Fi signal emitted by the Wifipool devices and the Wifipool cloud through our home network. We use our phone and ethernet connection (GEN2 only) to facilitate this connection.

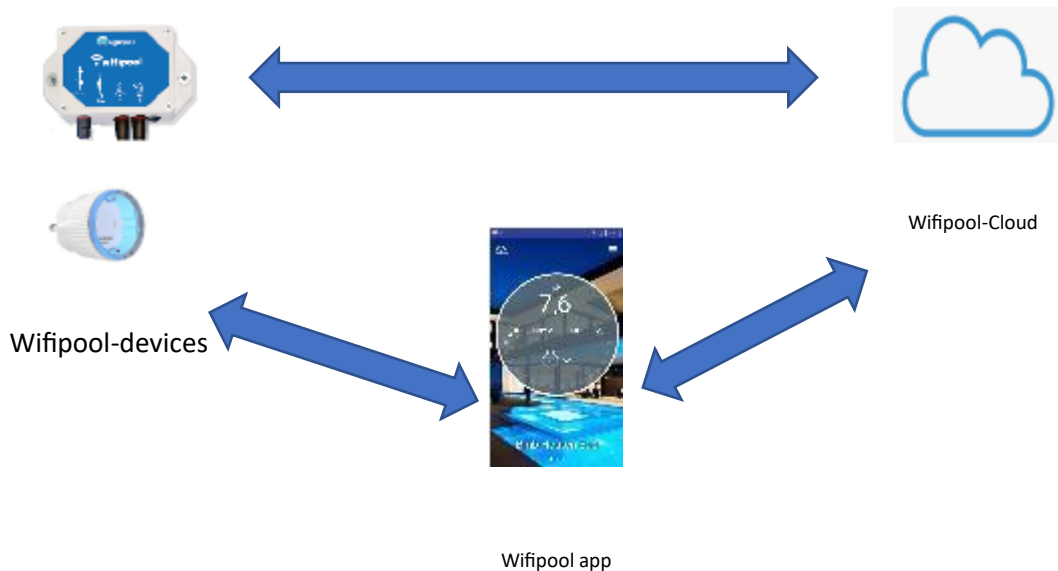

After pairing, the Wifipool devices will send data to the cloud, and they will receive instructions from the cloud. The communication occurs over the home Wi-Fi network and can be configured and monitored via the mobile phone.

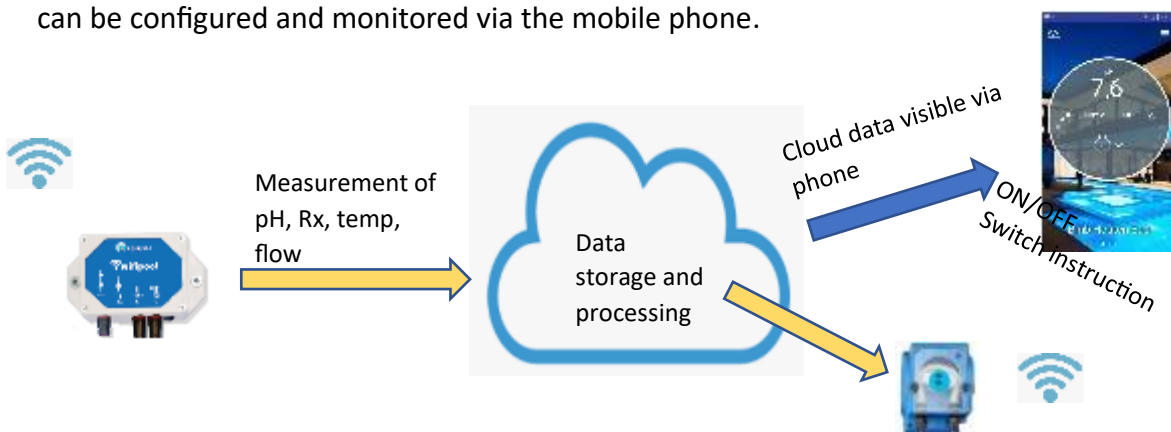

2.2. Problems with pairing

To ensure successful pairing, it's crucial to follow each step accurately. Both Android and iOS programmers have implemented intricate security measures, complicating the pairing process with several invisible security checks that must be confirmed.

The primary reason for pairing failures often stems from the instability of the home network. We strongly recommend conducting the pairing process indoors, close to the network source, and PRIOR to the physical installation of the devices. If you have a Gen2 Wifipool device, we recommend to pair via a ethernet connection.

Generally, pairing with Android proves to be easier compared to iOS. It's feasible to initially pair pool devices with an Android phone and then transfer ownership to an iOS device using the "Add user" feature (as mentioned above).

Once the pairing is complete, network stability becomes less critical. With Gen 2, these steps have been significantly streamlined, requiring only one-time pairing. Furthermore, it's not mandatory to pair via Wi-Fi; a cable connection is also an option, enhancing both the ease and reliability of the process.

2.3. Before pairing

If the board is not yet connected to a pool and no Ethernet connection has been established, the LED in the top right corner of the board will flash. In all other scenarios, it will not flash. This is the case when the board is already connected to a pool, either via Ethernet or WiFi. In this case, the LED will not flash, regardless of the type of connection (Ethernet or WiFi). It is important to note that if the LED on the board is flashing when the Ethernet connection is present, this does not mean that a connection to the Internet is available. If the Ethernet port is not flashing, no Internet connection is available.

Gen 1 (without) Ethernet

Led flashes when they are not paired and lights up 100% of the time after pairing. If they do not light up, they have no power, or the programming is wrong.

In previous generations, the red Shellys do not flash when they are not paired. However, the blue Shellys flash to indicate that they are ready to pair.



Both the small and the large plugs flash blue



First, ensure that the "Auto-join" feature in your Wi-Fi settings is activated. Without enabling this option on your smartphone, the network won't automatically reconnect, potentially causing issues when pairing your device. To activate this feature, navigate to the Settings app on your smartphone, then select "Wi-Fi" and tap the information ("i") icon. From there, toggle the "Auto-join" option to on, and proceed with the instructions below.

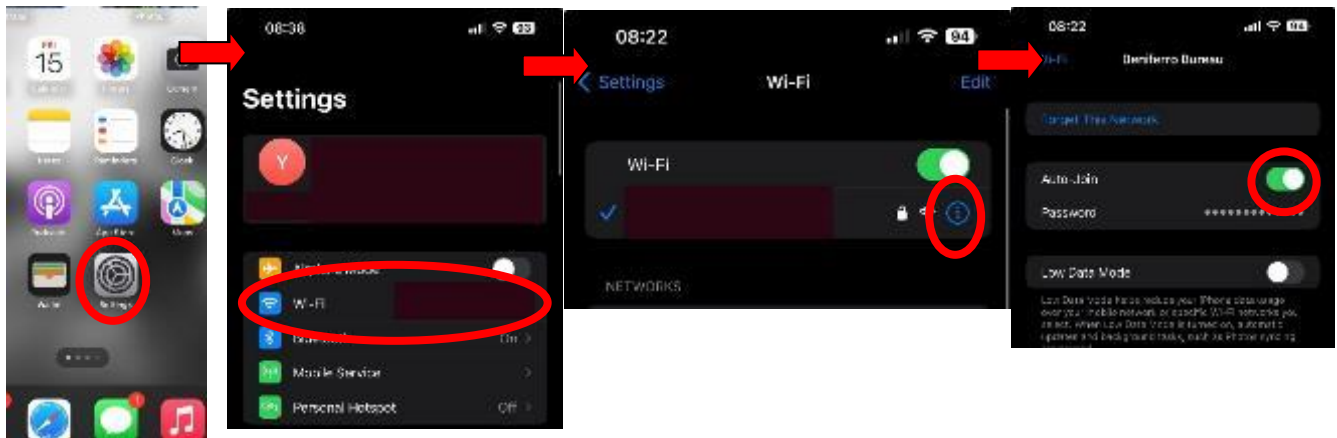

Before pairing with ethernet-connection:

1. Install the Wifipool app on your phone (as mentioned above).
2. Ensure you have an ethernet cable and connected to your device.



3. Make sure you have the instruction page (included with your order) with the device serial number and barcode. (See appendix 1).

Before pairing without ethernet connection:

1. Install the Wifipool app on your phone (as mentioned above).
2. Ensure you know the network names and password of your Wi-Fi network that you will use for your swimming pool.
3. Make sure you have the instruction page (included with your order) with the device serial number and barcode. (See appendix 1).

Additional Notes:

1. Take your time. The pairing process will take 5-30 minutes, depending on the number of devices to pair and the technique used.
2. Make sure the wifi products are used within the required technical specifications (see appendix 3), such as 2.4GHz wifi network, -20 to 70°C, dry environment, etc.
3. If the circuit board is not yet connected to a swimming pool and no Ethernet connection has been established, the LED on the top right corner of the circuit board will flash. In any other scenario, it will not flash. This applies when the circuit board is already connected to a pool, either via Ethernet or WiFi. In this situation, the LED will not flash, regardless of the connection type (Ethernet or WiFi). It is important to note that the flashing of the LED with the Ethernet connection on the circuit board is does not mea that a connection to internet is available. When the ethernet connector does not flas, no internet connection is available.

2.4.Pairing via ethernet

Pairing via ethernet is the preferred pairing method. The method is only available for Wifipool devices containing an ethernet connection, produced from 2024 onwards.

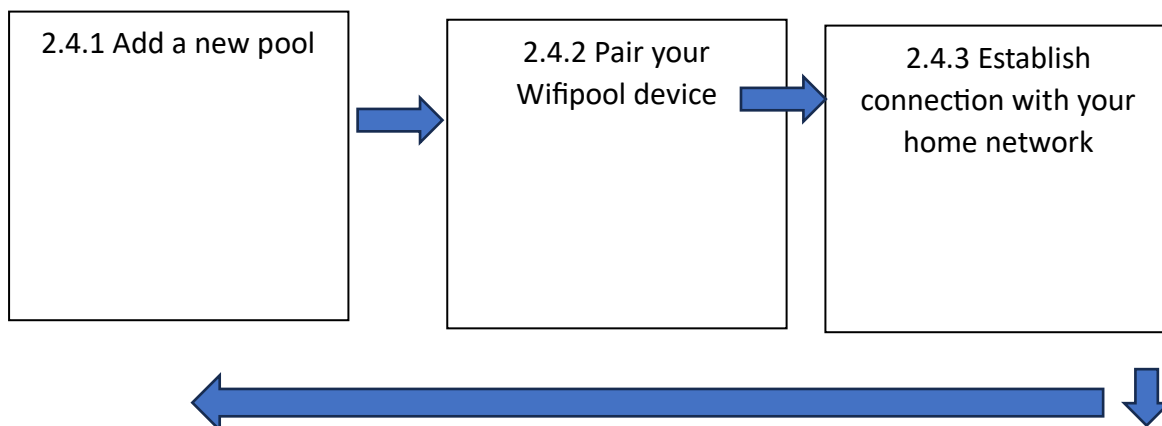

2.4.4 The device is added , automations are loaded and the phone returns to the Pool settings screen



2.4.5 Finalizing installation

2.4.1 Add new pool

Firstly, make sure you add a new pool, give it a unique name .

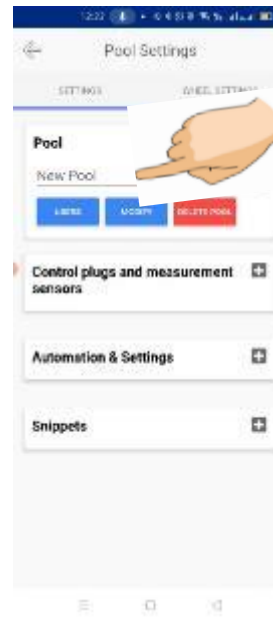
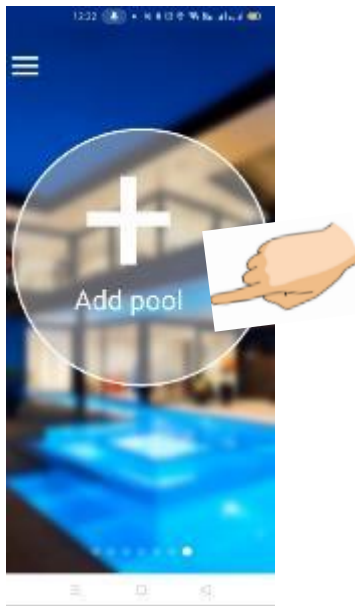

2.4.2 Pairing Wifipool device

Tap the plus icon next to "Control plugs and measurement sensors."

Always ensure that you connect your device using an Ethernet cable to establish a stable connection. If your router flashes a light, it indicates that the connection is successful.

Then, where it says "Scan the bar or 2D (QR) code on your device," tap "Start scanning" and proceed to scan the barcode on your device or on the "Startup information sheet" included in the box.

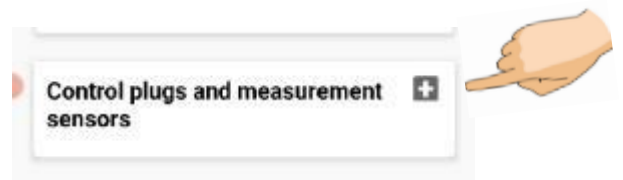

2.4.3 Connect to home network

The next step is different for Android vs IOS.

Android : you have to select your home network : the network which you will use for your swimming pool equipment.

IOS : You will have to enter the Swimming pool network name (SSID) and password manually.

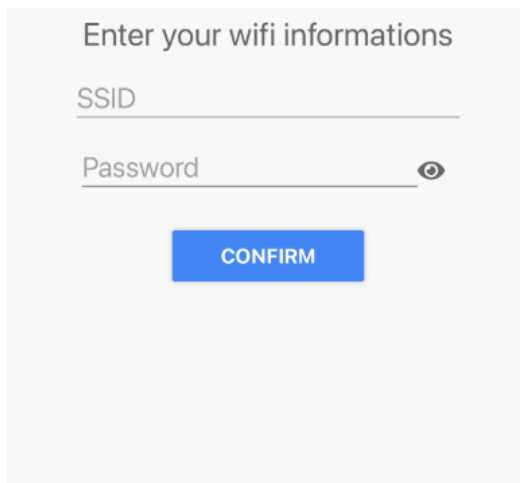
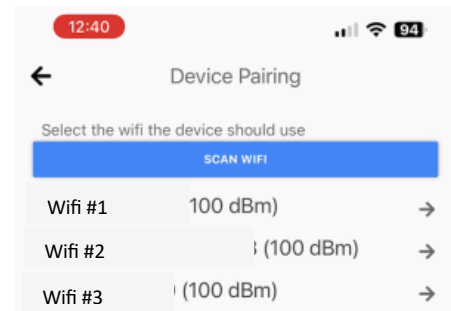
A screenshot of a web-based form titled "Enter your wifi informations". It has two input fields: "SSID" and "Password". The "Password" field has an eye icon to its right, indicating a toggle for visibility. Below the fields is a blue button labeled "CONFIRM".

Enter the correct password. Press the eye and check your password carefully, if you enter the wrong password, the app will go back to the main menu and your device will only remain connected as long as the device has ethernet connection. As soon as the ethernet cable is removed, connection will be lost.

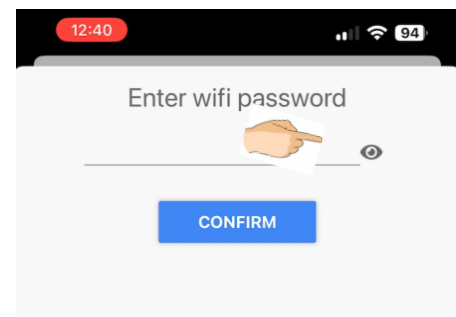

2.4.4 The device is added and the phone returns to the Pool settings screen

The app will return to the main screen. If not, close the app and open it again. A first device is now paired, and you will see the device in the Pool settings page.



2.4.4.1 Predefined Automation & Settings

With Gen 2, there may be predefined automation settings already configured. After installation, you can find them under "Automation & Settings." These settings are automatically activated once you start using them.

2.4.4.2 Wrong Wi-Fi password entered (ethernet)

In case your device is connected via ethernet, there won't be any error message if you have entered the wrong password. The menu will show a red signal next to your connection. Just unpair the device from the Wifipool app and go back to step 2.4.2



2.4.5 Finalizing installation

After the installation process is finished, go back to your pool settings.

Check if your control plugs and measuring modules are paired and functioning. If the indicator light turns green, it means they are paired. If it's red, it means there's (still) no connection. Always wait a moment until the indicator light turns green as it may take some time.



Note: Beniferro does not offer free technical support for pairing issues via Wi-Fi if you have an Ethernet device.

In case you have pH and RX probes, you need to calibrate your Wifipool device. This simple calibration process is explained in the quickstart manual of the equipment purchased

(More info about calibration, see chapter: Calibration) Once calibrated, you can seamlessly proceed with the physical installation of the device, ensuring optimal performance and accuracy in monitoring your pool's environment.

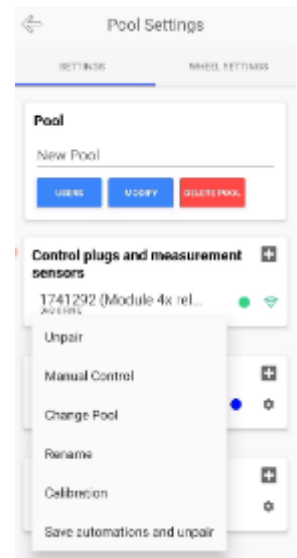

2.6. Pairing of the WIFIPPOOL-devices via Wifi for iOS devices.

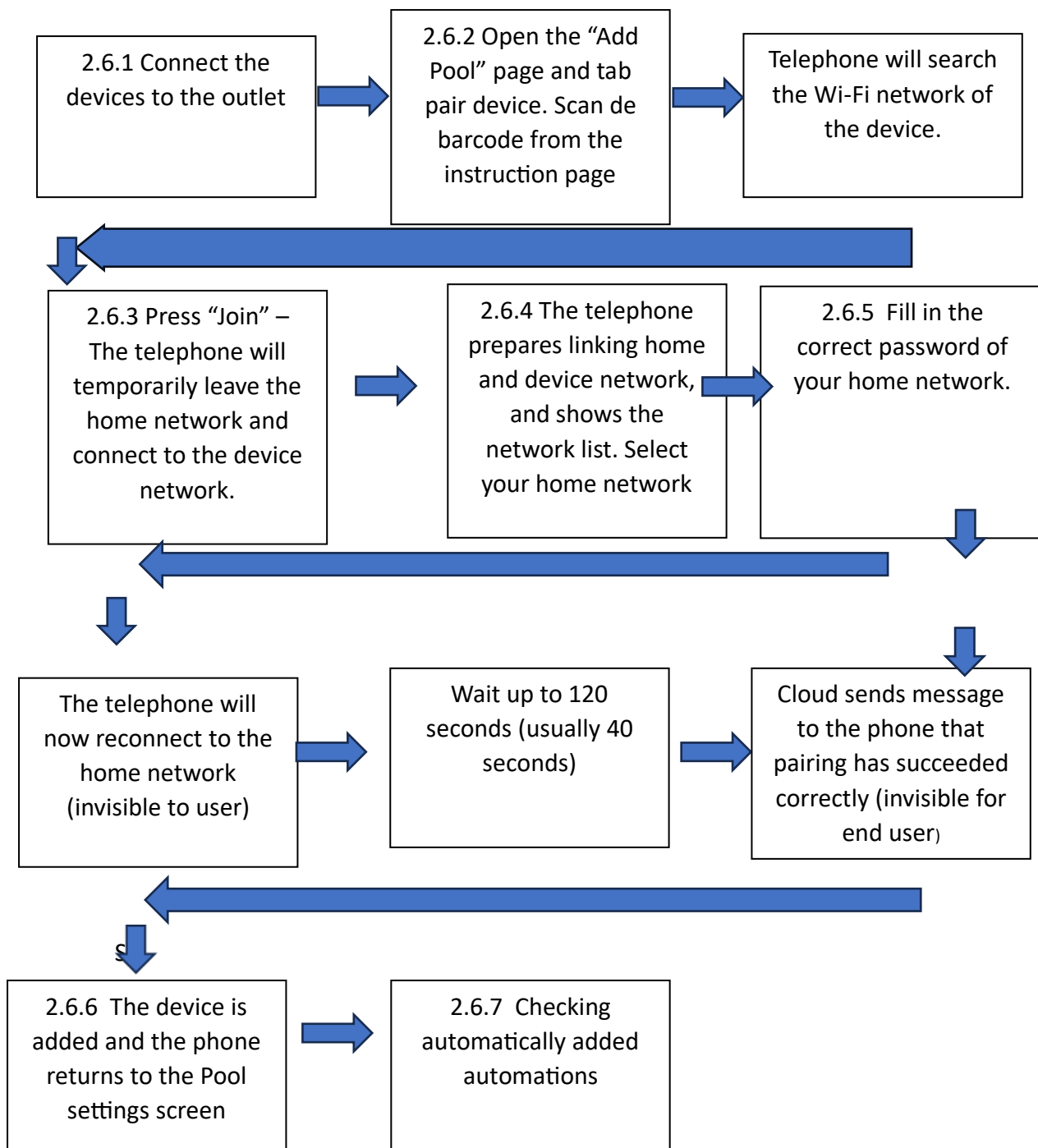

This pairing method is mandatory for Gen 1 devices (no ethernet connections) and is optional (but not recommended) for GEN 2 devices with ethernet connector.

The pairing needs to be completed for all the devices, before the pool automation can be entered into the system Please note: The manufacturer does NOT give free support for this pairing process if pairing via ethernet of webpage are available for your device.

2.6.1 Connect the devices to the outlet

After connecting the power, the Wifipool devices will emit a Wi-Fi signal. You will see the SSID of the devices in the available Wi-Fi list of your phone. The SSID is a combination of 6 and 4 letters/digits

In this example, there is a SSID for a pH pump, a salt electrolysis, a pH measurement and a Redox measurement.

Please note: If everything is paired successfully, you will no longer see these devices in your Wi-Fi settings

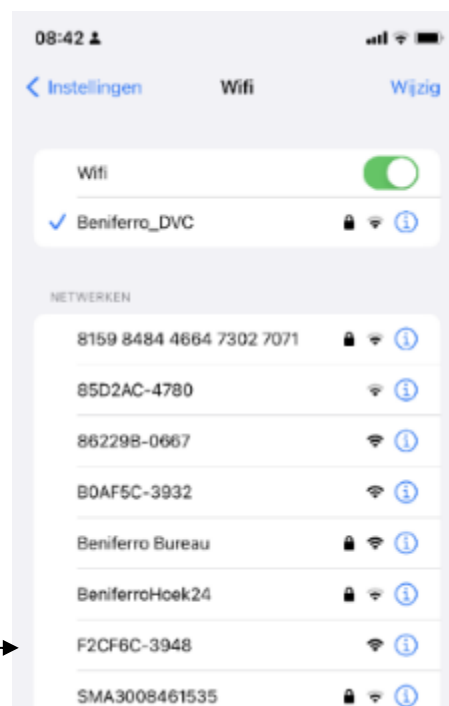

2.6.2 Connect the devices to your phone one by one. To do this, go to the pool settings on the Main screen and tick the Pool name (1), and press 2 on the "Control Plugs and Measurement Sensors" section and press + (press 2). Scan the first barcode on the instruction sheet that came with the products you purchased.

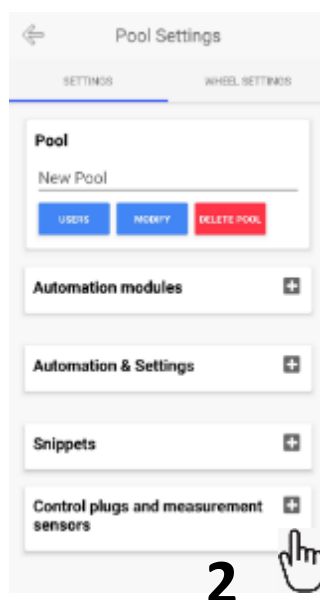

Start scanning



2.6.3 Press “Join” – The telephone will temporarily leave the home network and connect to the device network.

After scanning, a short notification will be displayed indicating that the Wi-Fi pool device is being connected to the phone.



The app will start searching for your WiFi networks, your device would no longer show the WiFi icon at the top right for a short moment.

2.6.4 The telephone prepares linking home and device network, and shows the network list. Select your home network : the network which is most active around your pool.

2.6.5 In the next step you have to select your home network : the network which you will use for your swimming pool equipment.

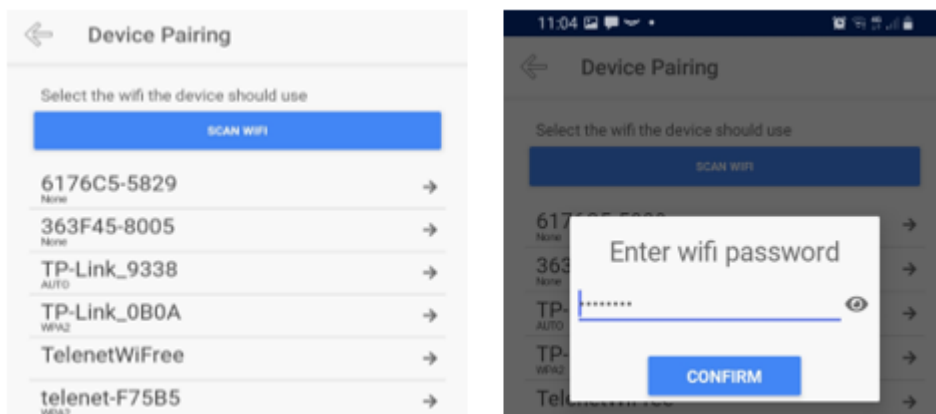

Enter the **correct** password Press the eye and check your password carefully, if you enter the wrong password, the app will go back to the main menu and show the following message: "The pairing process has failed".

The wrong password will now be saved, so if you reuse the saved password on a next attempt, the attempt will fail again.

If the correct password is entered, the phone will now start searching for the network and start the pairing process. During this period, do not interrupt the system, do not move the devices or the phone. Just be patient and wait. It takes usually +- 40 seconds to complete the process, but on other occasions it may take up to 120 seconds.

The last step of this process is a communication from the cloud to your phone (message not visible for end user), that the pairing process was successful.

2.6.6 The device is added and the phone returns to the Pool settings screen



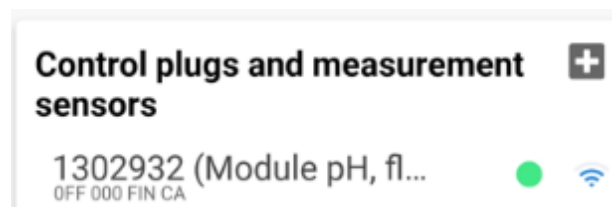



The app will return to the main screen. If not, close the app and open it again. A first device is now paired, and you will see the device in the Pool settings page.



2.6.7 Connect remaining devices

Repeat steps 2.6.1 to 2.6.6 until all devices are paired. You will now see your devices in the Pool settings page. A red circle behind the device indicates the device is not connected to the Wi-Fi. A green circle means the device is connected.

Control plugs and measurement sensors

1302901 (Module pH, fl... <small>OFF 000 FIN CA</small>		
1439745 (Module pH, fl... <small>OFF 000 FIN CA</small>		
1090507 (Plug 16A) <small>OGZ 000 FIN AA</small>		
1352157 (Module Temp... <small>OFF 200 FIN CA</small>		

2.6.8 Checking automatically added automations

Ensure to first verify whether any preprogrammed automations (appendix 1) are already present. This may be the case if you just paired a Gen 2 device. These will conveniently appear under the section titled “Automation & Settings”. Should you find that there are no automations listed, take the initiative to manually incRXorate them by scanning the provided barcodes. This step ensures comprehensive control and optimization of your device's functionalities. See the quick start-up manual of the equipment purchased.

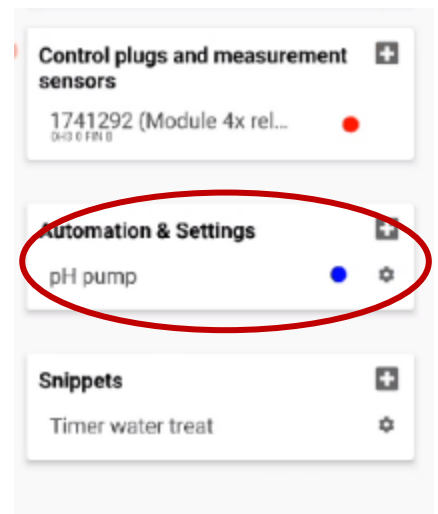

a. Pairing the WIFIPPOOL devices via WIFI on a Android phone

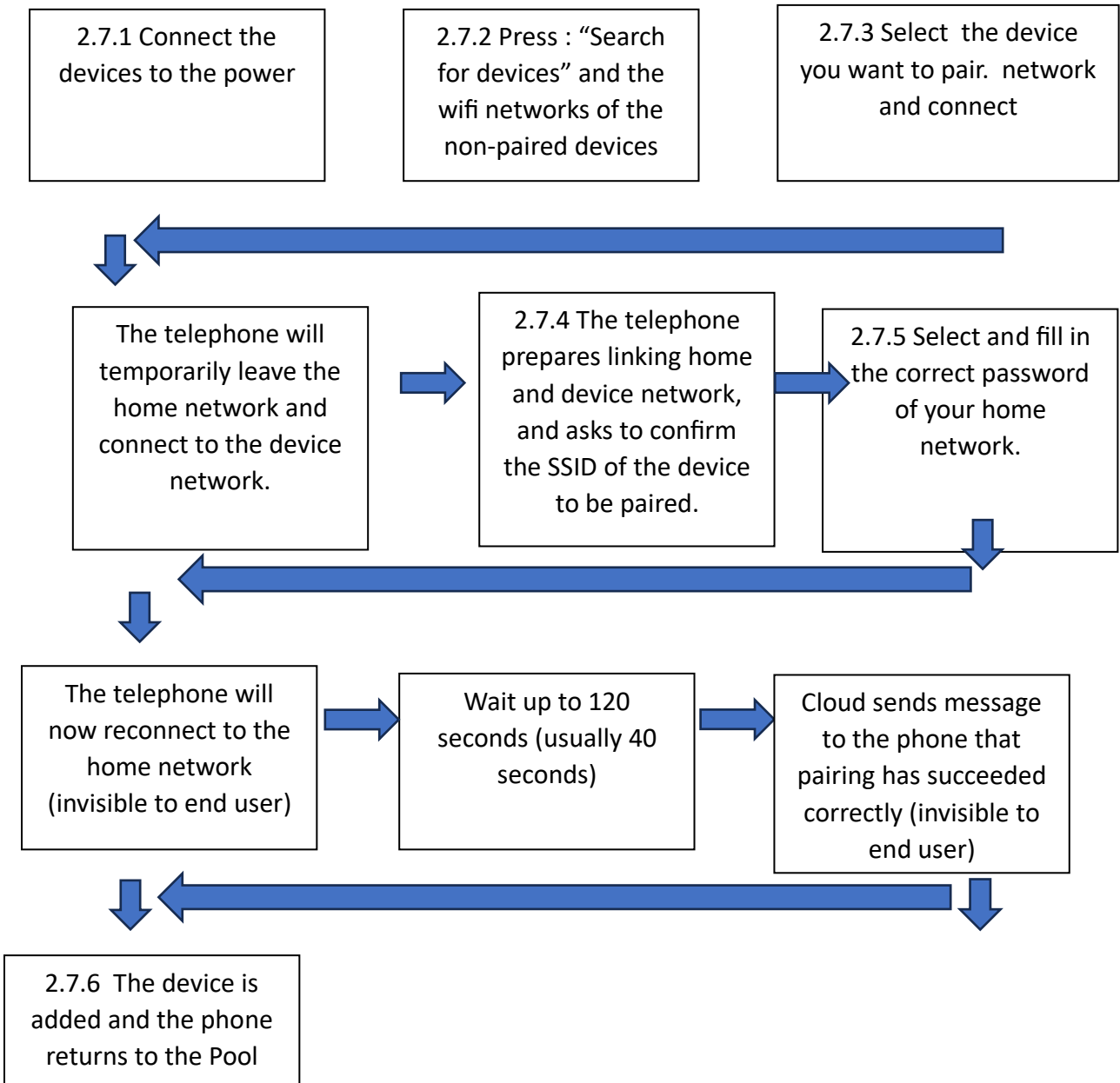

The pairing needs to be completed for all the devices, before the pool automation can be entered into the system

Attention : The manufacturer does NOT give free support for this pairing process if pairing via ethernet or webpage are available for your device.

2.7.1 Connect the devices to the power

After connecting the power, the Wifipool devices will emit a Wi-Fi signal. You will see the SSID of the devices in the available Wi-Fi list of your phone. The SSID is a combination of 6 and 4 letters/digits

- letters/digits
- In this example, there is a SSID for a pH pump, a salt electrolysis, a pH measurement and a Redox measurement.

Please note: If everything is paired successfully,

- you will no longer see these devices in your Wi-Fi settings

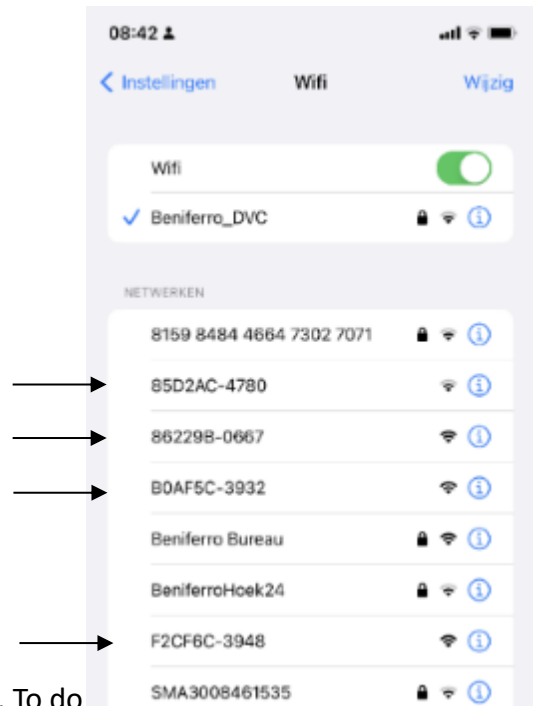

2.7.2 Connect the devices to your phone one by one. To do this, go to the Main screen and tick the Pool name (1), and on the "Control Plugs and Measurement Sensors" section press + (2). Subsequently start the « search for devices »(3), and select the device you want to pair (4).

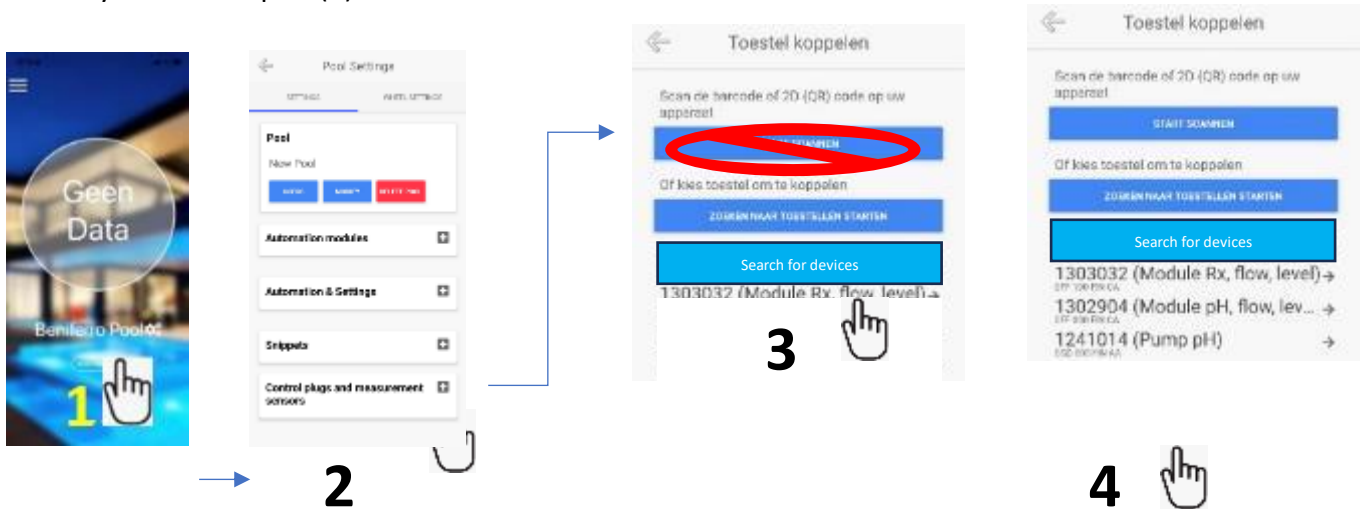

2.7.3 Press "Connect" – The telephone will temporarily leave the home network and connect to the device network.

2.7.4 The telephone prepares linking home and device network, and asks to confirm the SSID of the device to be paired.



2.7.5 In the next step you have to select your home network : the network which you will use for your swimming pool equipment.

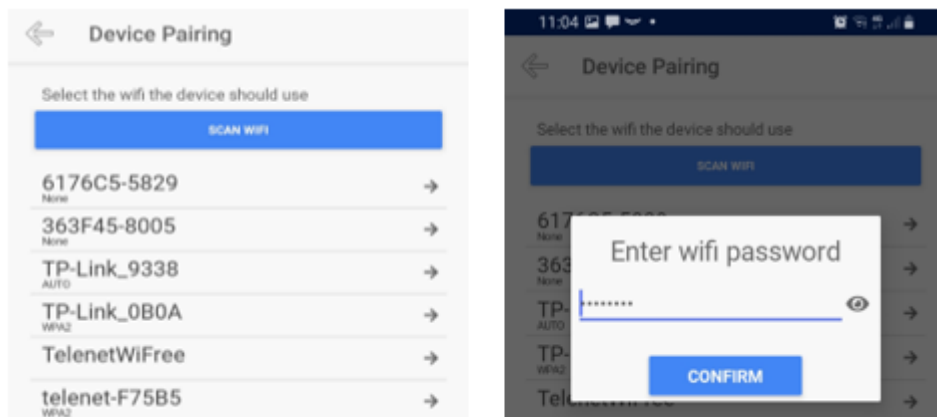

Enter the **correct** password Press the eye and check your password carefully, if you enter the wrong password, the app will go back to the main menu and show the following message: "The pairing process has failed".

If the wrong password is entered and saved, subsequent attempts with the same password will also fail. However, if the correct password is entered, the phone will initiate the network search and begin the pairing process. It's crucial not to interrupt the system during this period or move the devices or phone.

Please be patient and wait. Typically, this process takes approximately 40 seconds to complete, but in some cases, it may take up to 120 seconds. The final step involves a

communication from the cloud to your phone (a message not visible to the end user) confirming that the pairing process was successful.

2.7.6 The device is added and the phone returns to the Pool settings screen or to the main screen. If not, close the app and open it again. A first device is now paired, and you will see the device in the Pool settings page.

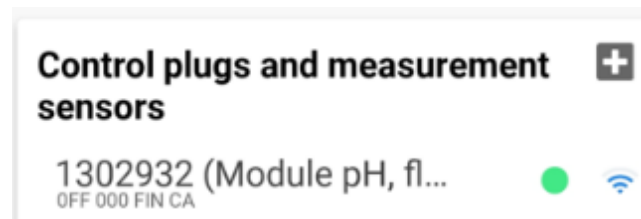

2.7.7 Connect remaining devices

Repeat steps 4.4.1 to 4.4.6 for each device until all devices are paired. Once paired, you will see your devices listed in the Pool settings page. A red circle behind the device indicates that the device is not connected to Wi-Fi, while a green circle signifies that the device is connected.

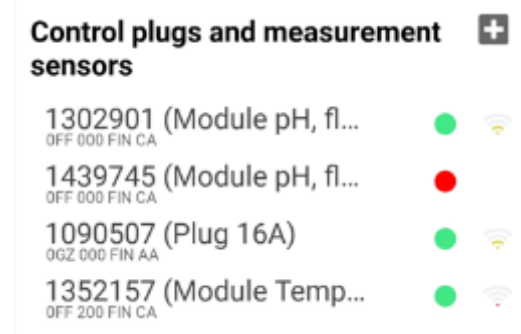

2.7.8 Checking automatically added automations

Ensure to first verify whether any preprogrammed automations (appendix 1) are already present. This is the case for GEN2 devices. These will conveniently appear under the section titled "Automation & Settings". Should you find that there are no automations listed, take the initiative to manually incorporate them by scanning the provided barcodes. This step ensures comprehensive control and optimization of your device's functionalities. Barcodes and instructions are found in the quick startup manual of the device purchased.

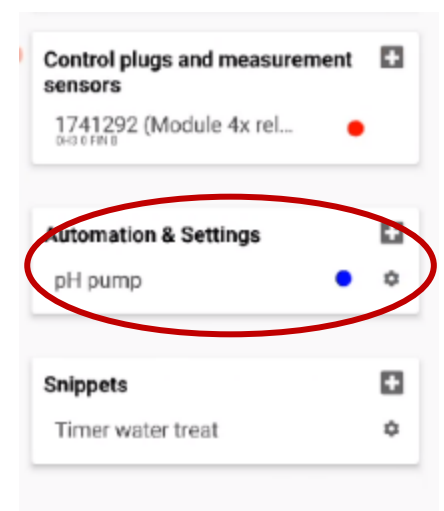

2.8 Pairing Problem solving IOS and Android

Step 2.6.6 / 4.5.6 Error: Wi-Fi connection failed - Possible causes:

- The home Wi-Fi network is not strong enough, unstable or absent in the zone in which you want to pair.

Solution for Gen 1:

Check that your phone is connected to your home network used for the pool. If not, select the appropriate network and ensure the phone remains connected during the pairing process.

Verify that the Wifipool network(s) in the format of 6 Characters/Digits - 4 Characters/Digits (e.g., 85C927-2343) is/are present in your phone's networks. Each unpaired device should display a network. After a power outage, it may take up to 3 minutes for the network to be visible.

If the device network is visible: Attempt to pair again from step 2.6.2.

If the device network is not visible, ensure the device is plugged in correctly (check the USB plug). If plugged in correctly, then reset the device by plugging and unplugging 7 times (each approximately 2 seconds). Wait until the Wifipool network is visible and your phone is connected to the correct home network, then attempt pairing again in the strong network zone from step 2.6.2.

If the error persists, contact your supplier after reading the section: 'What to do if I need to contact the supplier?'

Solution for Gen 2:

Check that your phone is connected to your home network used for the pool. If not, select the appropriate network and ensure the phone remains connected during the pairing process.

Verify that the Wifipool network(s) in the format of 6 Characters/Digits - 4 Characters/Digits (e.g., 85C927-2343) is/are present in your phone's networks, or for gen 2 devices, there can be more characters/digit – 9 digits and 4 characters (e.g., 975C93534-3850) . Each unpaired device should display a network. After a power outage, it may take up to 3 minutes for the network to be visible.

If the device network is visible: Attempt to pair again from step 2.6.2.

If the device network is not visible, ensure the device is plugged in correctly (check the USB plug). Unplug the device and wait 40 seconds and plug it back in. Wait until the Wifipool network is visible and your phone is connected to the correct home network, then attempt pairing again in the strong network zone from step 2.6.2.

If the error persists, contact your supplier after reading the section: 'What to do if I need to contact the supplier?'"

There is no assistance for WiFi connection problems, so pairing via ethernet is recommended

Step 2.6.6 / 2.7.6 Error: Pairing failed

Possible causes:

The home and/or device Wi-Fi network isn't strong enough or absent from the zone where you want to pair. Make sure your phone is near both home Wi-Fi and device Wi-Fi. Best is to do the pairing in-house before installing the pool equipment.

Solution:

1 Wait another 60 seconds after seeing the error message and verify if the device is not paired after all. If so, you will see your device on the Pool Setting page.

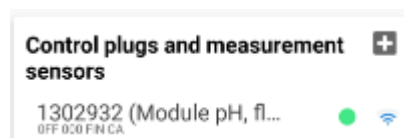

2. Check that the Wifipool network(s) in the formats 6 Characters/Digits - 4 Characters/Digits - For example, 85C927-2343 is/are present in your phone's networks. For each unpaired device, a network is visible. After a power outage, it takes up to 3 minutes for the network to be visible.

If the device network is visible : Try to pair again from step 2.6.2 / 2.7.2

If the device network is not visible, verify that the device is indeed plugged-in (also check that the USB plug is working correctly). If plugged in correctly, then reset the device by plugging in and unplugging 7 times (each +- 2 seconds). Then wait until you can see the Wifipool network and that your phone is connected to the correct home network, and try again to pair in the strong network zone from step 2.6.2 / 2.7.2

If the operation 7 times (each +- 2 seconds) has not worked, verify that the home network is indeed powerful at the location of the device. If the device is left for 15 minutes in the strong network zone to which it was paired (or partially paired), the device may reset itself.

If this error returns, contact your supplier after reading the section : What to do if I need to contact the supplier ?

Step 2.6.6 . 2.7.6 Error: Pairing Process failed - Possible causes:

Possible cause : The password you use for your home Wi-Fi network was entered incorrectly (and the wrong password was saved).

After a 120 minutes waiting time, a error message will display : The pairing process failed. Home network instability, or not strong enough in the pairing zone or too much distance between device, home network and phone.

Solution: Enter the password manually and verify the password when pairing the devices.

Step 2.6.6 / 2.7.6 : Error: "wrong password"

Issue 3: "Wrong Wifi password"

Possible causes:

1. You entered the wrong password
2. You switched the pairing methods from Ethernet to non-Ethernet

Solution:

1. Try pairing again and make sure to fill in the right password.
2. Reset the plug or the measuring box by disconnecting it from the power outlet for 30 seconds and then plugging it back in.

If you are connecting with Ethernet, make sure to plug in your cable before pairing. If you are connecting with Wifi, make sure there is definitely no Ethernet cable connected before pairing.

Step 2.6.2 / 2.7.2 : "Unable to connect to network 'Wi-Fi pool device name'

Possible causes:

The Wi-Fi pool device Wi-Fi network is not strong enough or absent in the zone in which you want to perform the pairing.

Your phone is too far from the Wi-Fi pool device



Solution:

1. Check that the Wifipool network(s) in the formats 6 Characters/Digits - 4 Characters/Digits - For example, 85C927-2343 is present in your phone's networks. For gen2 there can be more characters/digits. For each unpaired device, there is a network. After a power outage, it takes 3 minutes for the network to be visible.

If the network is visible: retry to pair from step 2.6.2 / 2.7.2 in a zone where all the networks (Wifipool networks and your home pool network) are strong.

If the device network is not visible, verify that the device is indeed plugged-in (also check that the USB plug is working correctly). If plugged in correctly, then reset the device by plugging in and unplugging 7 times (each +- 2 seconds). Then wait until you can see the Wifipool network and that your phone is connected to the correct home network, and try again to pair in the strong network zone from step 2.6.2

If the operation 7 times (each +- 2 seconds) has not worked, verify that the home network is indeed powerful at the location of the device. If the device is left for 15 minutes in the strong network zone to which it was paired (or partially paired), the device may reset itself.

If this error returns, contact your supplier after reading the section : What to do if I need to contact the supplier ?

Step b2 2.6.2 : Home Wi-Fi network is not visible

Solution: On iPhone the network screen doesn't always show up over the full length of the device. Scroll down the network list to check if you can see the network.

Step b2 2.6.2 : Wi-Fi network are not displaying correctly (undefined NaN dBm)

Solution: press the "scan Wi-Fi" button multiple times until your networks are accurately detected and displayed.



Step 2.6.2 / 2.7.2 : "The device cannot be paired because it is already connected to another pool"

Solution:

Check if you can see the device in the pool settings page . If this is the case, everything is fine.

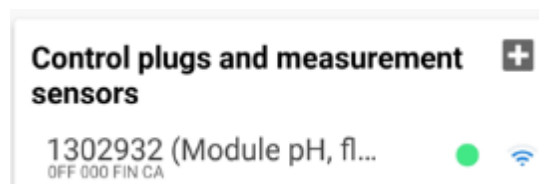
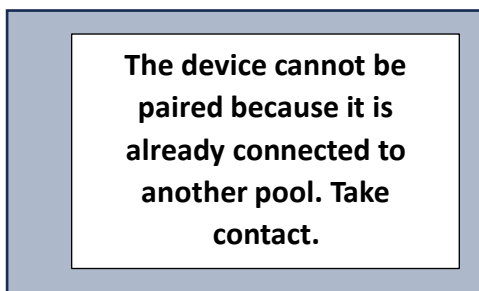

If the device network is not visible, verify that the device is indeed plugged-in (also check that the USB plug is working correctly). If plugged in correctly, then reset the device by plugging in and unplugging 7 times (each +- 2 seconds). Then wait until you can see the Wifipool network and that your phone is connected to the correct home network, and try again to pair in the strong network zone from step 2.6.2 / 2.7.2

If this error returns, contact your supplier. It can remotely perform an additional reset of the Wi-Fi pool device.

What to do if I need to contact the supplier ?

Please act as follows:

1. Plug in and out the devices that are not working
2. Please send a photo of the barcodes provided for pairing. These can be found on the Connect Go/Pro control box or on the pairing instruction sheet included with the delivery.



3. Send a screenshot with all your home networks. All devices should be shown on the screenshot.

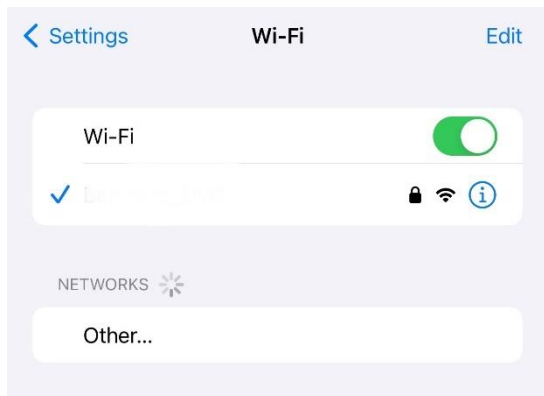

Please wait until all the networks are displayed, and then send a screenshot of the entire list.

4. Send a screenshot of the pool settings where we can see the control plugs and measurement sensors that are paired

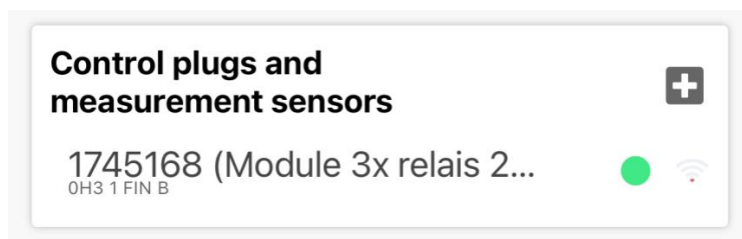

5 Add info@beniferro.eu as user to your pool, promote 2 times to the level of co-owner.

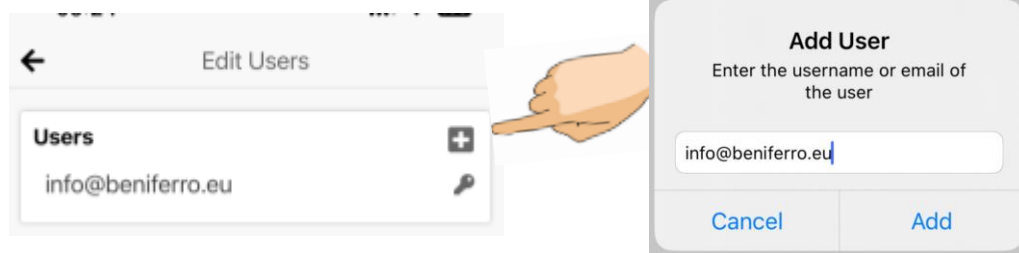

See section 3.1.1.2.1 below

Please send this information along with the problem description and the name of your pool to info@beniferro.eu.

3. Using the Wifipool app

3.1. Pool Settings

The Pool settings page is the page with which you will add new equipment (such as plugs and measurement boxes) , and define how your pool will be controlled. Via this page you can add additional users, edit the pool characteristics and verify the status of devices and automations.

There are 2 ways to enter the Pool settings page :

From the main page click directly on your swimming pool name or on the 3 bars in the top left corner

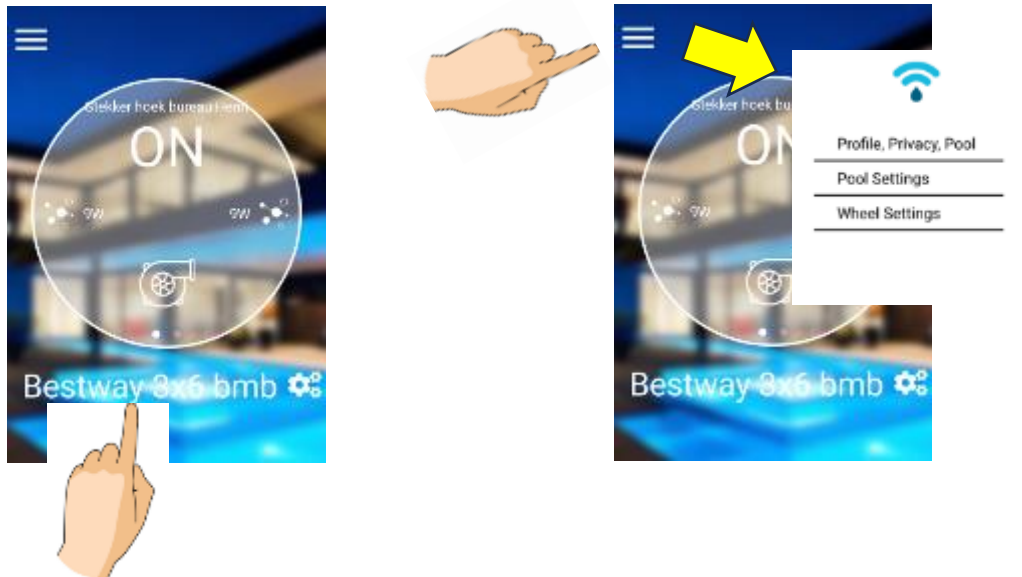

3.1.1. Pool

3.1.1.1. Pool Name

Give your swimming pool a name. In case you share your pool with other people (see “users”, it is important to choose a recognizable and original name. Type in your new pool name in the text field.

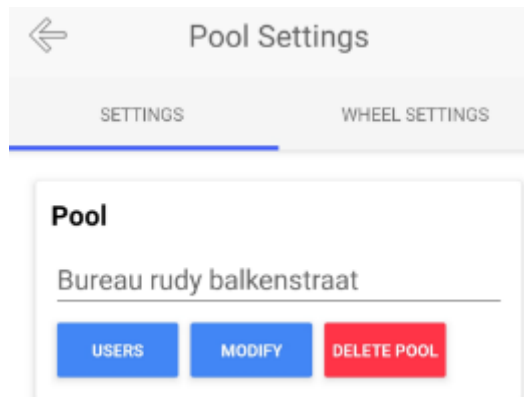

3.1.1.2. Users

3.1.1.2.1. Adding users

Via the "Users" tab, you can let other people watch or control your pool.

Go to the pool settings page and select users

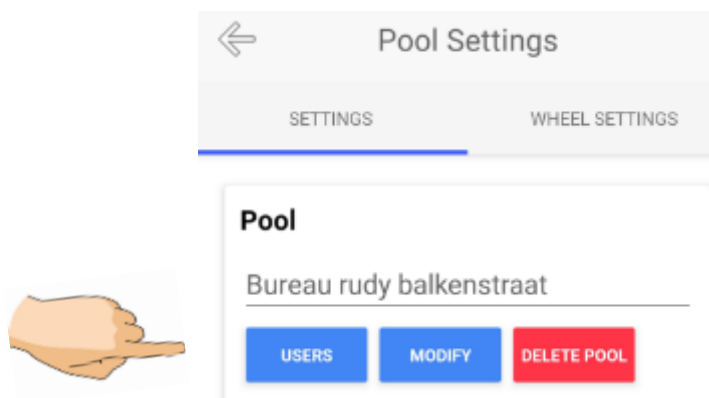

You can now add users to your pool. Click on the little plus symbol in the right top corner of the screen. The user is directly added to the pool. This user is "Read only" (3.1.1.2.1).

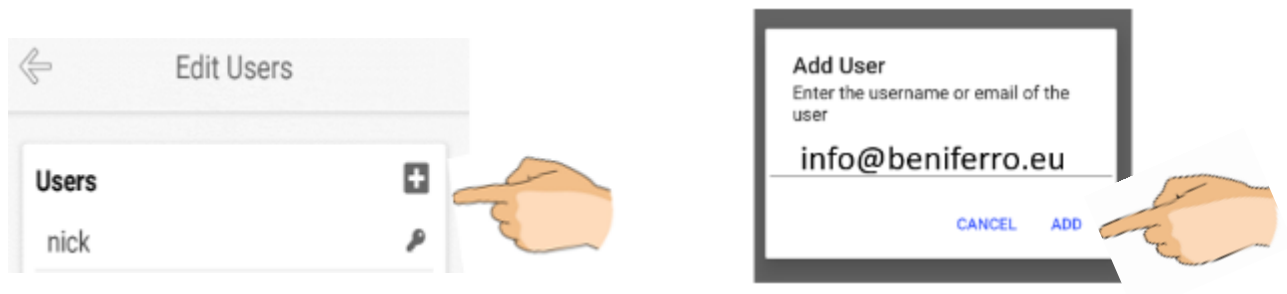



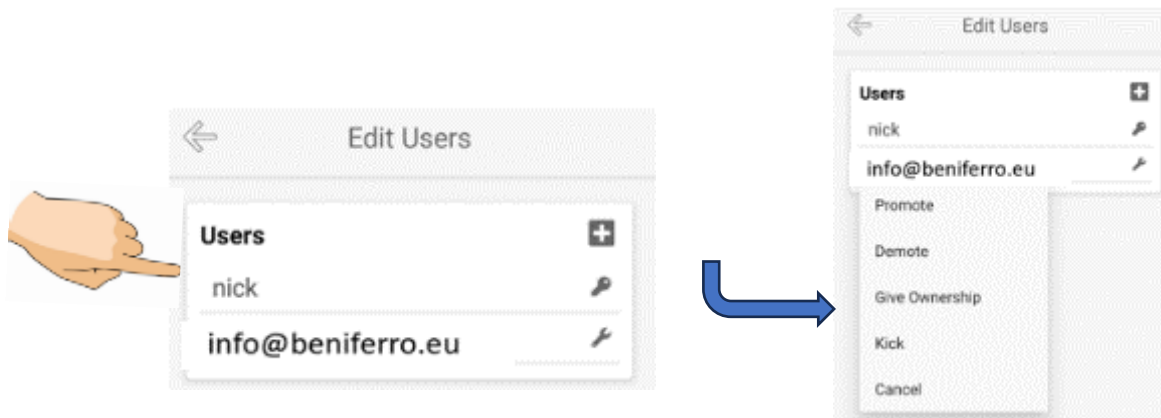

A popup window appears where you can type in the Wifipool username of the person you want to add.

3.1.1.2.1. Manage user rights

Click on the name of a user from the menu



There are 4 levels of restrictions you can add for each User

-  Owner : can control the swimming pool, add, promote, give ownership and kick out users
-  Co-owner : can control the swimming pool and add and promote users
-  Partner : can look at the swimming pool and receive notifications
-  Read only

Be aware that once you give up your own rights as an owner and this user now has the rights to kick you out as a user.

By promoting info@beniferro.eu to the level of co-owner, you can give the manufacturer access to your pool. This is a helpful feature in case help or troubleshooting is requested. In this case, make sure your pool has a recognizable and original name.

3.1.1.3. Modify Pool Characteristics

By pressing the modify button, you can edit and change your Pool characteristics. Filling in the Pool characteristics (such as Pool volume / Pool type...), will allow the app, to send you advice on your pool.

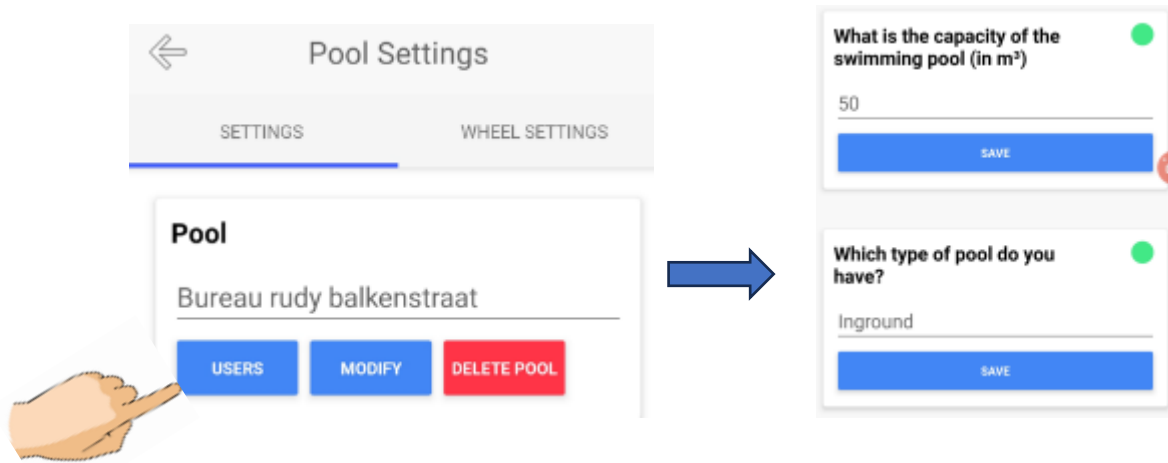

3.1.1.4. Delete Pool

Using this option will fully delete your pool, all pairing and automations. This action cannot be restored.

Please note: if you happened to delete your pool by accident. You have to manually reset your devices connected to the swimming pool.

3.1.2. Control plugs and measurements

The “Control plugs and measurements” section allows the user to have a quick overview of the devices in the swimming pool and their connection to the wifi network.

In addition, some direct controls such as calibration, manual control etc. are initiated via this section.

Before a device can be used, it needs to be paired with your home network and telephone. The pairing process of the control plugs and measurement devices has been described above.

After pairing, all devices are listed. The green circle indicates the device is connected to Wi-Fi, a red circle is not connected to the Wi-Fi. The number in front of each device is the serial number of the device.

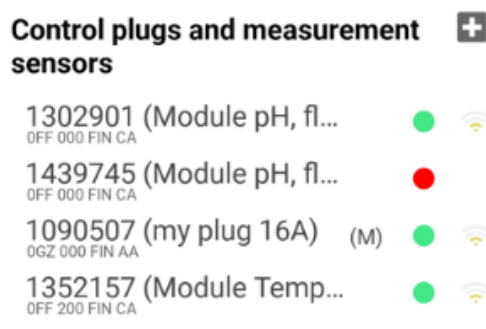

3.1.2.1. Unpair

The unpair / delete option will „delete“ a device, and make it available for other users / other swimming pools; Tick on the device name in “control plugs and measurement sensors”, followed by “unpair or delete”.

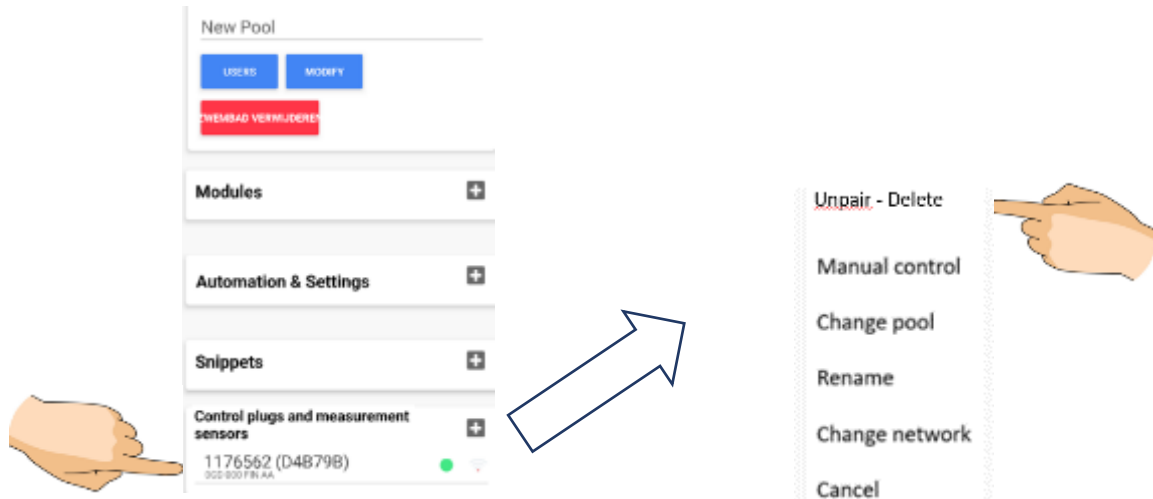

3.1.2.2. Manual control

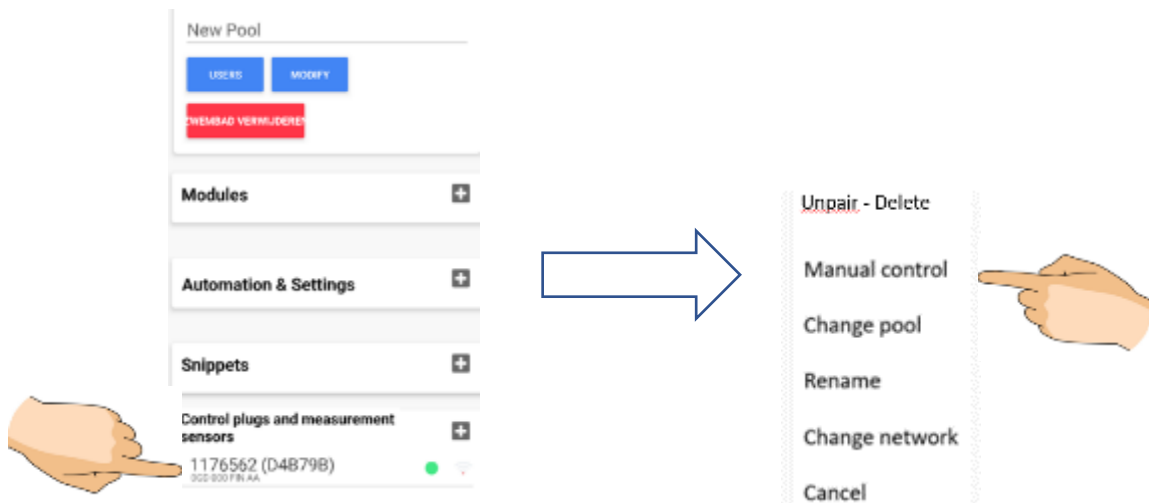

Click on manual control to switch from automatic to manual control. When using manual control, the owner, co-owner and partner of the Wifipool account, can start and stop manually the plug or smart switch. Although manual control can be helpful, it also contains risks. In case the pH peristaltic pump is started manually, it will keep on dosing liquid into the pool, regardless if this is needed or not.

Therefore, it is necessary to acknowledge that you have been informed of the risks associated with manual control, before you can access the control itself.

Once entered the manual control, it is possible to return to automatic via the green “switch to automatic button” . You can toggle the pump (or other device) on or off by tapping or swiping the grey toggle to the left or to the right.

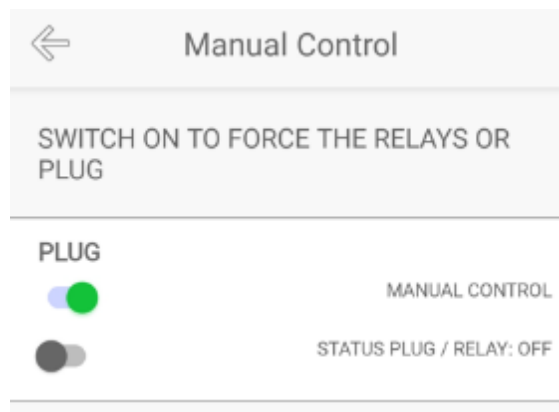

On the Pool setting screen, plugs and smart switches in manual mode, will be indicated with a “M” .Upon hitting the device name, a menu will unfold, by which it is possible to return to the automatic mode



3.1.2.3. Rename

Select Rename and enter in the new name for your plug. It is advisable to select a name which makes it clear which equipment this plug is controlling (eg Filter pump, pH peristaltic pump

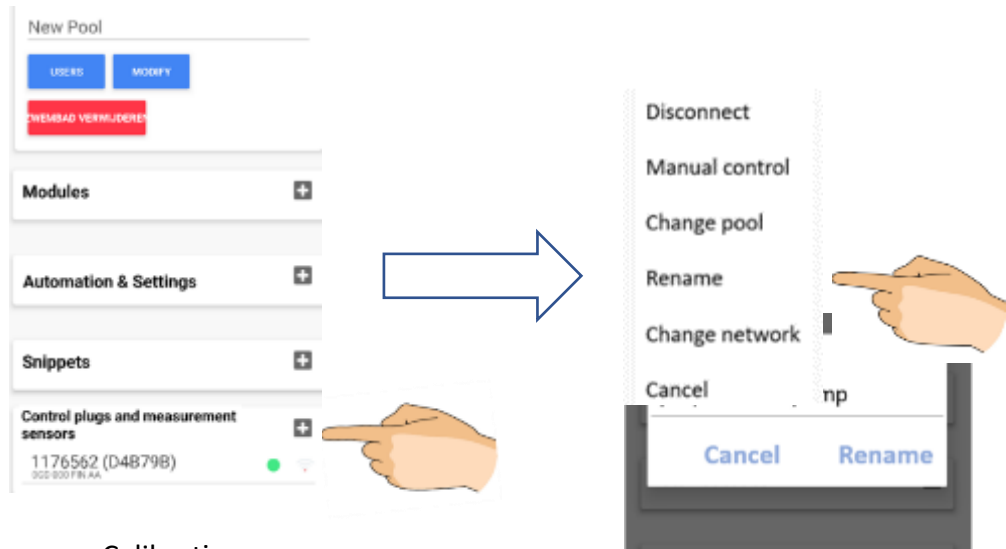

3.1.2.4. Calibration

To initiate the calibration process, tap on the pH or RX module line ("Module" in title) is between brackets. Once selected, the menu options will unfold, revealing a tab labeled "Calibration." Ensure you are prepared to remove the pH or RX probe from the installation and place it in the pH or RX calibration solution.

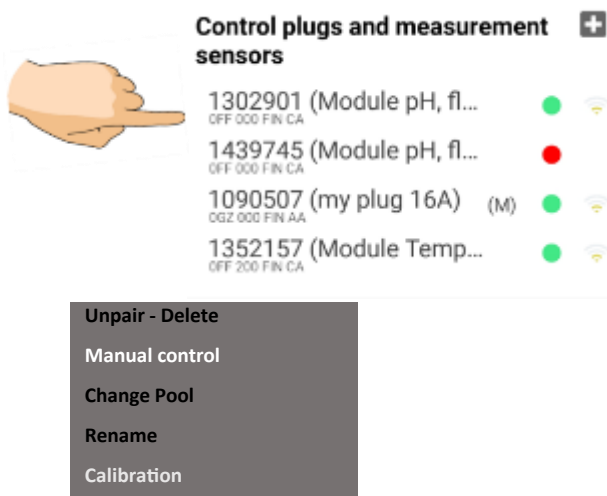

Follow the instructions on the screen to proceed with calibration.

3.1.2.5. Change Pool

3.2. Automation & Setting

With Gen 2, preprogrammed automations streamline the process by eliminating the need for manually adding automations check appendix 1 for extra info.

An automation makes the link between the measurements of a pool and a smart plug (or smart switch). Using the measurement results, we will start-stop a plug or smart switch. It is also possible to set up a timer and/or notifications in the automations

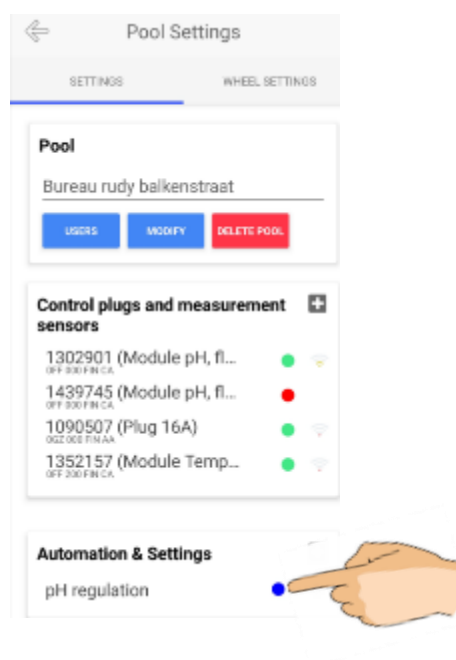

A blue circle behind the automation indicated the automation is not active because the target value has been reached, or because one of the conditions (e.g. a timer) stops the automation from running.

A green circle indicates the automation is running (e.g. pH pump is running).

The Wifipool automations have a feature called « duty cycle » .

A duty cycle of 30% / 60 seconds means that the power to the device being controlled will be on during 18 seconds each 60 seconds.

By enabling the duty cycle, it is possible to slow down the dosing of peristaltic pumps, enabling efficient water treatment in small volume pools and spas.

Attention:

The duty cycle parameter should not be adjusted by standard users. Altering this value can significantly disrupt the functionality and accuracy of your dosing device. Any modifications to these settings should only be performed by qualified personnel. Therefore, we strongly advise against making any changes to these parameters.

The Duty Cycle should never be used in combination with salt electrolysis or other pieces of equipment containing a control PCB.

The software is programmed with hysteresis. Hysteresis is a feature that helps prevent the device from switching on and off too frequently. Think of it like a buffer zone: it allows the device to wait for a small range before making adjustments, ensuring smoother and more stable operation. For example, in our system, the hysteresis for pH is set at 0.01, and for redox, it is set between at 10. This means the device will only make changes if the pH or redox levels move beyond these small ranges, preventing constant switching and ensuring accurate control.

3.2.1. Existing automation module

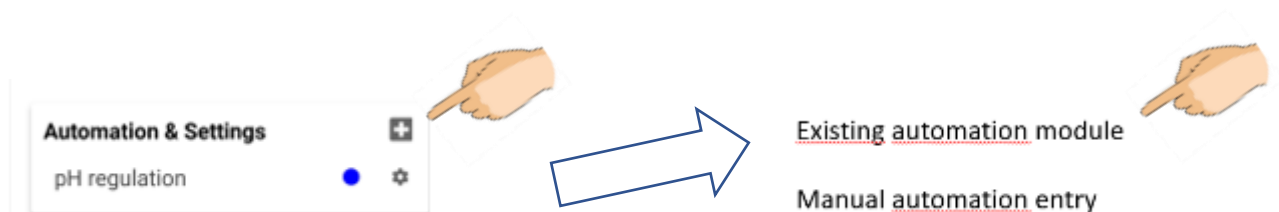

The existing automation module option allows the user to use a pre-defined automation module. The customer can choose between selecting a pre-defined automation or can scan a barcode from the manual joint to the product purchased.



Scanning the barcode or pressing the “Water treatment Liquid chlorine and acid for swimming pool, flow and level switch” link will have the same result : the full pre-defined automation will be installed on your swimming pool.

In this example, the regulation will be as follows :

pH and RX regulation (pH master)
 Daily Scheduler for water treatment between 9:30 and 17:30
 Notification sent to the phone if pH or RX is very high (>9) or low (<5.5) or no flow or low level.
 Safety stop if no flow or pH > 9 or RX >950 or level switch = low.

Appendix 1 gives an overview of the automation barcodes available.

The pre-defined automations contain all elements necessary to control correctly the equipment, including timers, notifications, safety stops if pool values deviate abnormally etc ...

We recommend to use a pre-defined automation and, if desired, adjust the values to your wishes. In the example below : press the « 7.6 » to modify the pH target value.

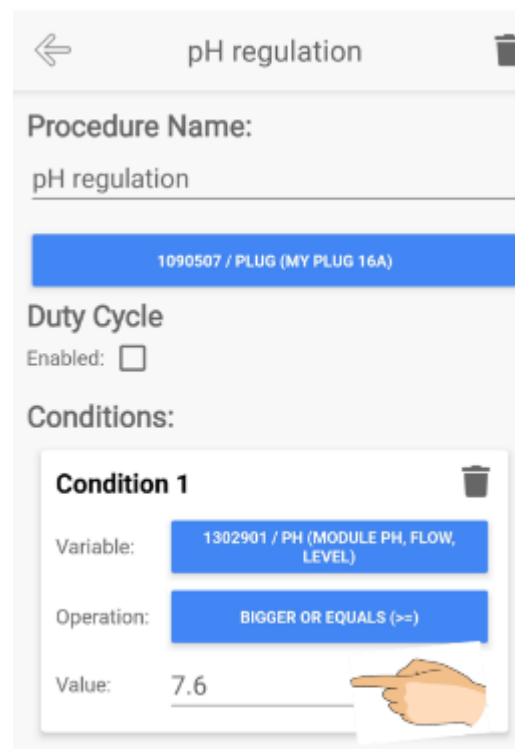

3.2.2. Manual automation entry

The automations can be entered manually as follows :

- Click on the **+** sign in the right corner, next to automations your pool settings tab which opens the “new procedure” page. Enter a name for you procedure

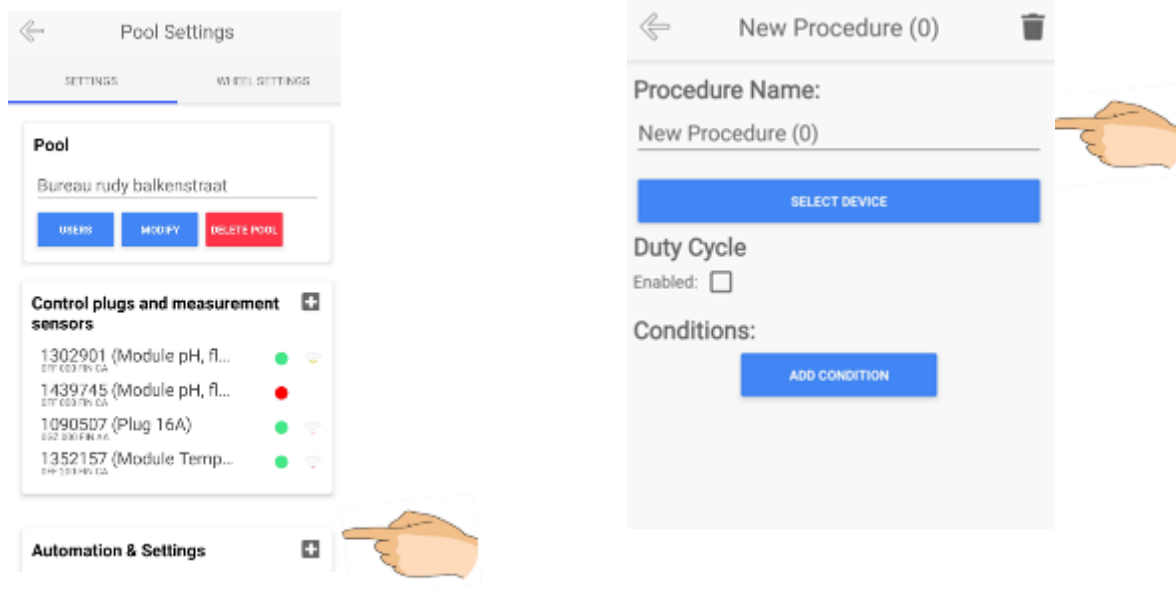

- Select the Wifipool device (plug , smart switch (or equipment containing a smart switch such as a peristaltic pump) you want to start and stop.

OR

- Select Push notifications to define de conditions under which you have to receive a notification.

In the example below, we create the procedure “pH control” by selecting our pH peristaltic pump as action device

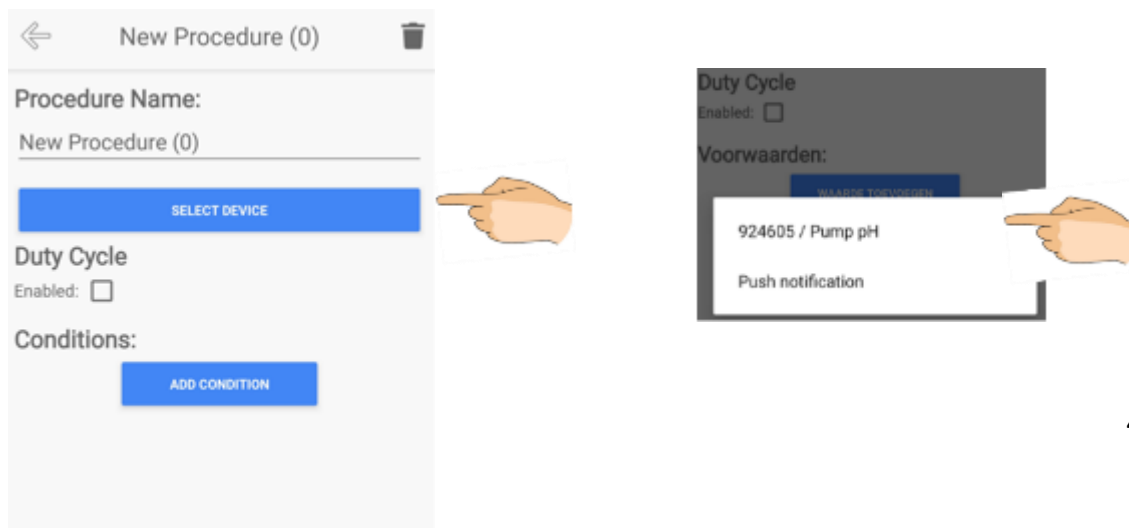

- Define the condition

By pressing the “Add condition” button, we can select conditions at which the pH pump has to turn on. In our pH control example, we choose to start the pH pump (when the pH is larger or equal to (\geq)7.6 AND (by adding once again a condition) the flow switch detects flow.

In the example below, the pH pump will run only if $\text{pH} \geq 7.6$ AND the flow switch detects flow.

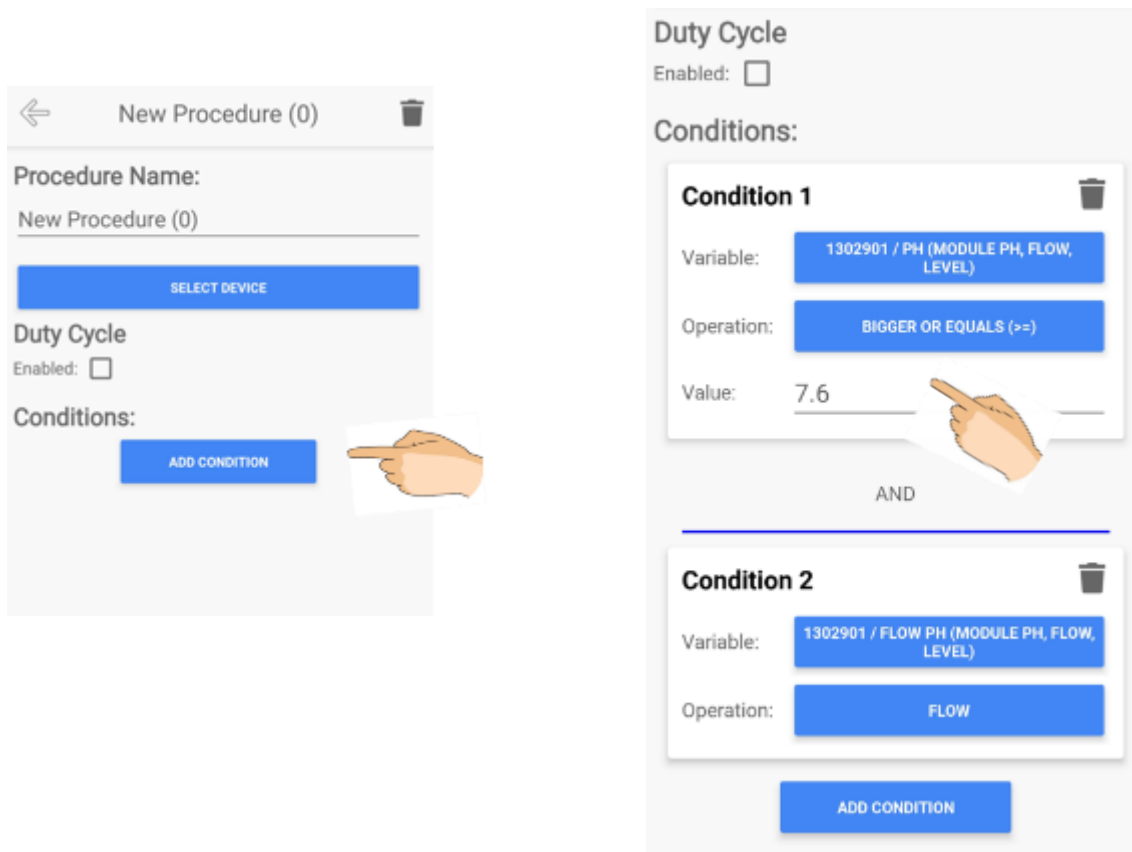

A unlimited number of conditions can be added

- Duty cycle:

With the duty cycle you are able to select the intensity for your device (output) to run on.
For example: Duty cycle % 30 Period (s) 60

This means that during the period of 60 seconds your device will run for 18sec in total (30% of the interval)

Click on enabled if you would like to use the duty cycle and in the values for your desired duty cycle

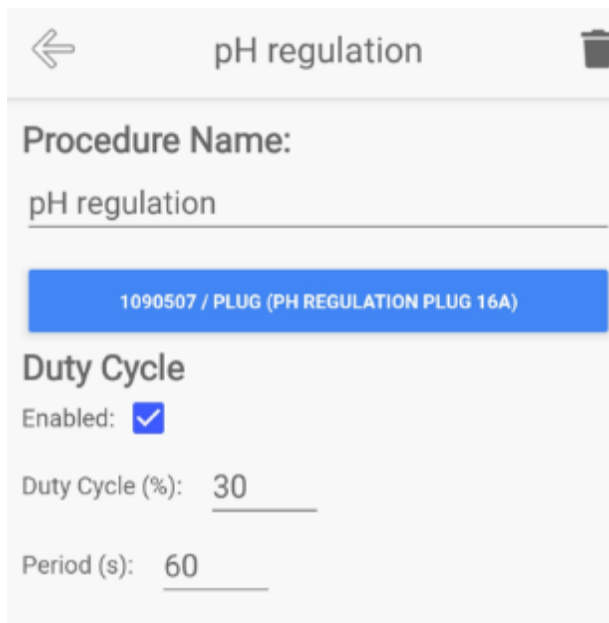

The screenshot shows a mobile application interface for 'pH regulation'. At the top, there is a back arrow on the left, the title 'pH regulation' in the center, and a trash icon on the right. Below the title bar, the 'Procedure Name:' is set to 'pH regulation'. A blue button with the text '1090507 / PLUG (PH REGULATION PLUG 16A)' is visible. Underneath, the 'Duty Cycle' section is shown with 'Enabled:' checked (indicated by a blue checkmark). The 'Duty Cycle (%)' is set to '30' and the 'Period (s)' is set to '60'.

In our example , the pH pump will run 30% of 60 seconds (= 18 secondes) per minute IF the pH > 7.6 AND flow is detected.

The duty cycle is typically used to reduce the dosing speed of peristaltic pumps.

Attention : never use the duty cycle with instruments which start up via a control PCB such as a salt electrolysis, frequency regulator, heat pump etcThe duty cycle will cause the instrument to switch on and off very frequently. This may cause electroic failure.

- Timer - scheduler

When selecting a condition, “Scheduler” is a option. When selecting the scheduler, a weekly schedule can be filled in.

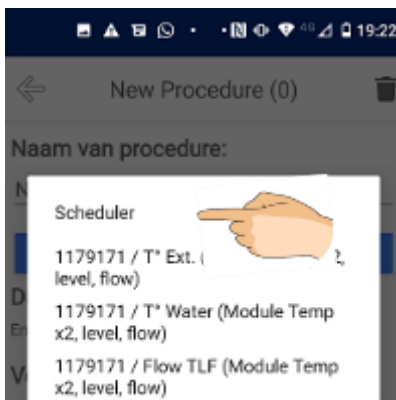

A weekly schedule will open, in which different time slots per day can be programmed

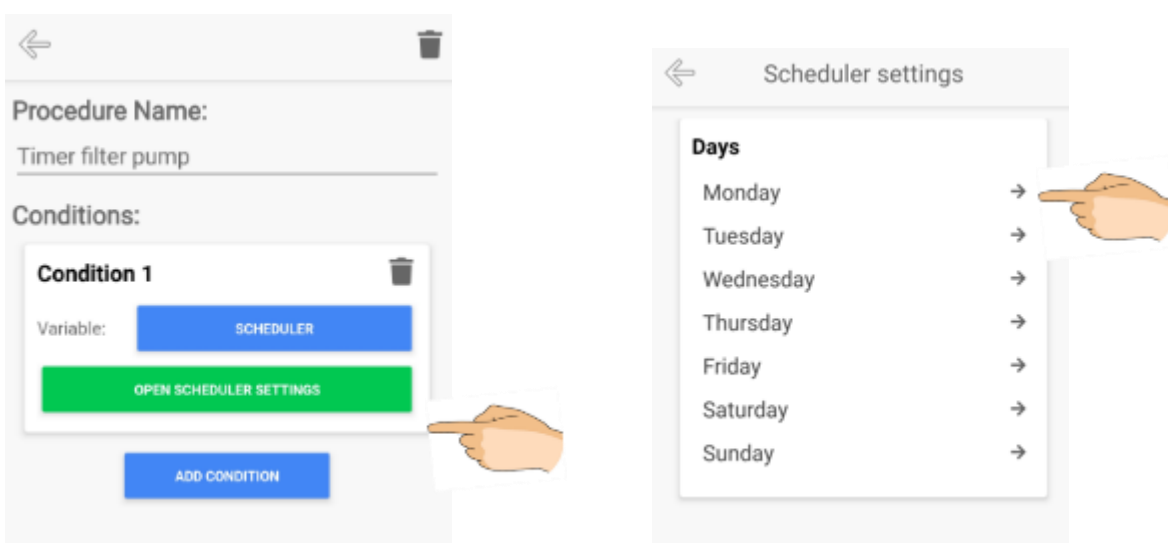

A alternative option for the scheduler, is to define a scheduler within the Snippets, and then selecting the Snippet as a condition. This has the advantage that the same timer can be used for several plugs / smart swtichtes.

3.3. Snippets

Snippets are “schedulers » which repeat themselves in several automations. As an example : the „Filter pump scheduler“, can be used for the filter pump as well as for the UV lamp plug.

Activate the Snippets by pressing the + sign, and complete and save the snippet just as described above in the “timer“ section

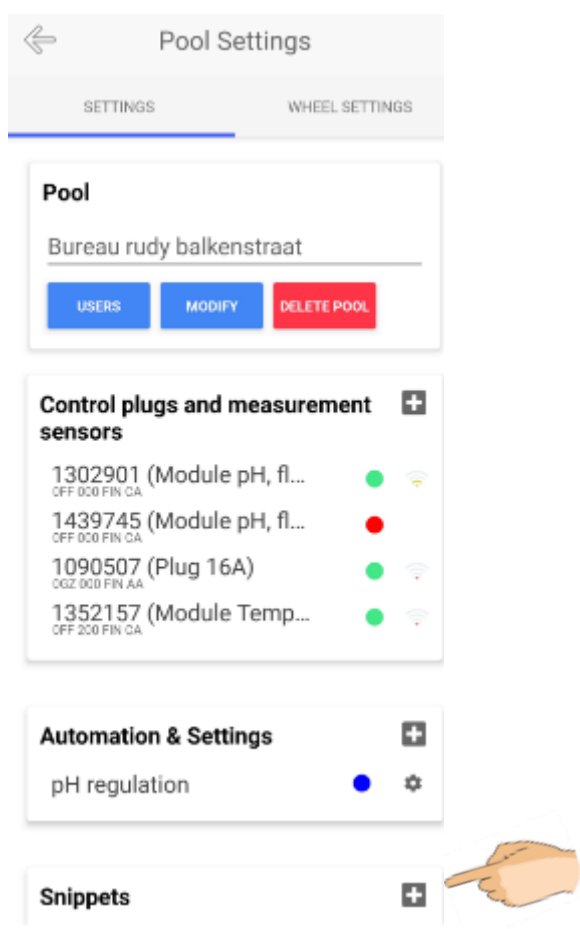

3.4. Notification scheduler

Adding a notification schedule

1. Scroll down to snippets. And press the plus icon. This will add a new snippet. Press the new snippet and change the “Procedure name” to something more appropriate (e.g. Notification scheduler). And press “Add condition”.

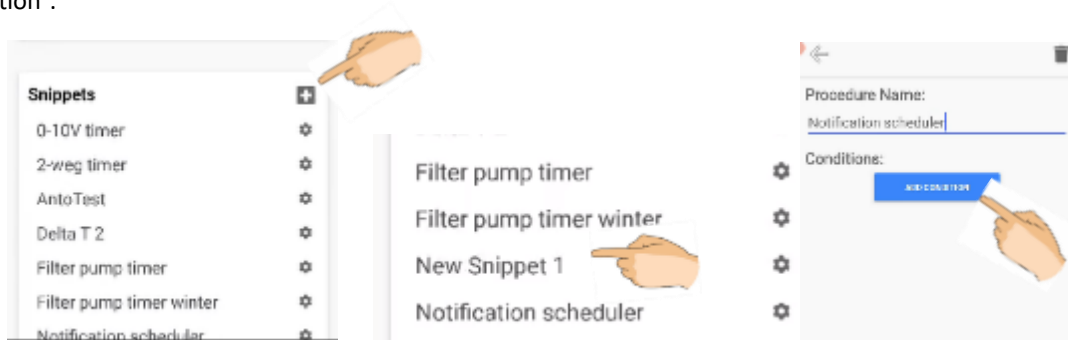

2. In the newly added condition just press “Select measurement”. All the way on top you’ll see an option with “Schedule” just select this.

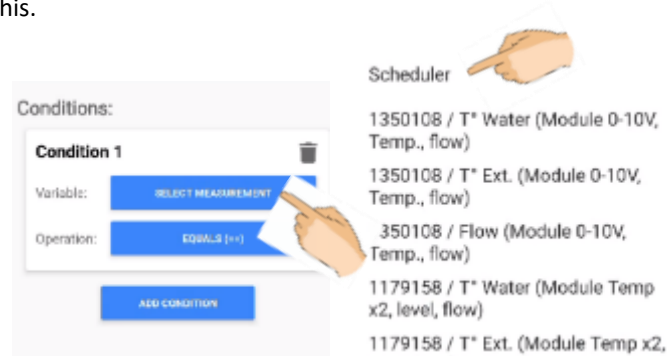

3. You can open the schedule settings now by pressing “Open schedule settings”. All days of the week will be displayed. Open for example Monday, and tab “add more” to add a new interval.

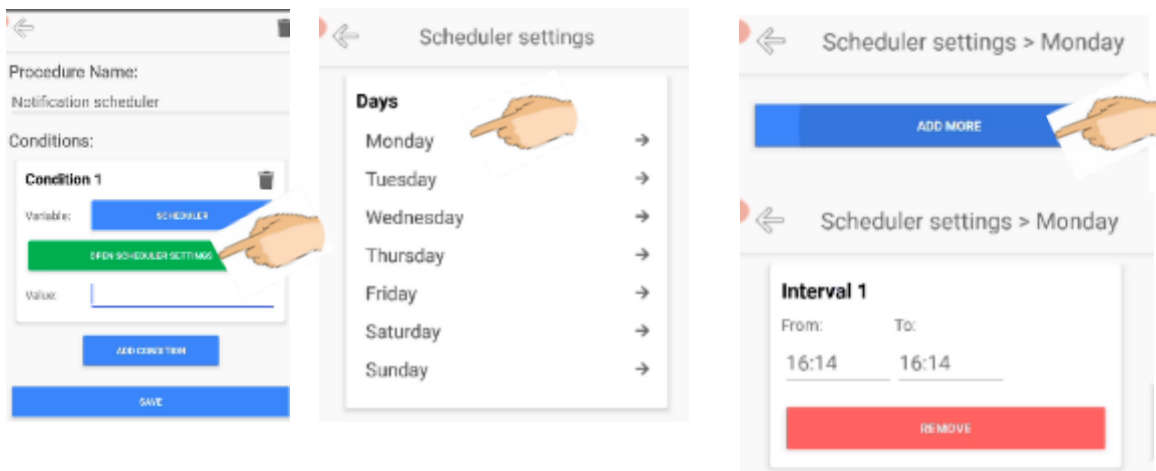

4. Modify the interval time “from” (when to start your operation) and “to” (when to stop your operation). E.g. 10:00 to 16:00. You have to manually change this for each day of the week. And press “OK”.

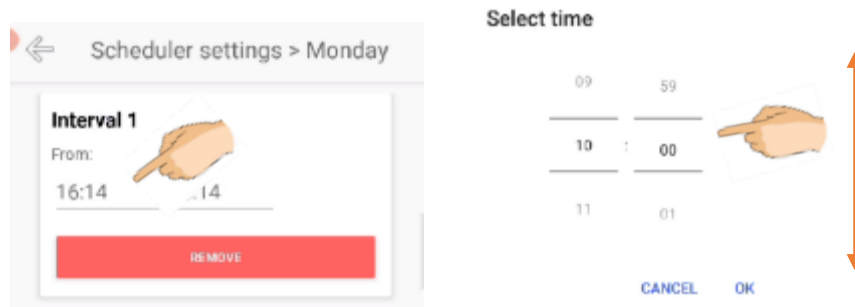

5. Once that's complete just navigate back to your Procedure settings and press save. After that you can go back to your pool settings and follow the instructions below to add an alarm notification.

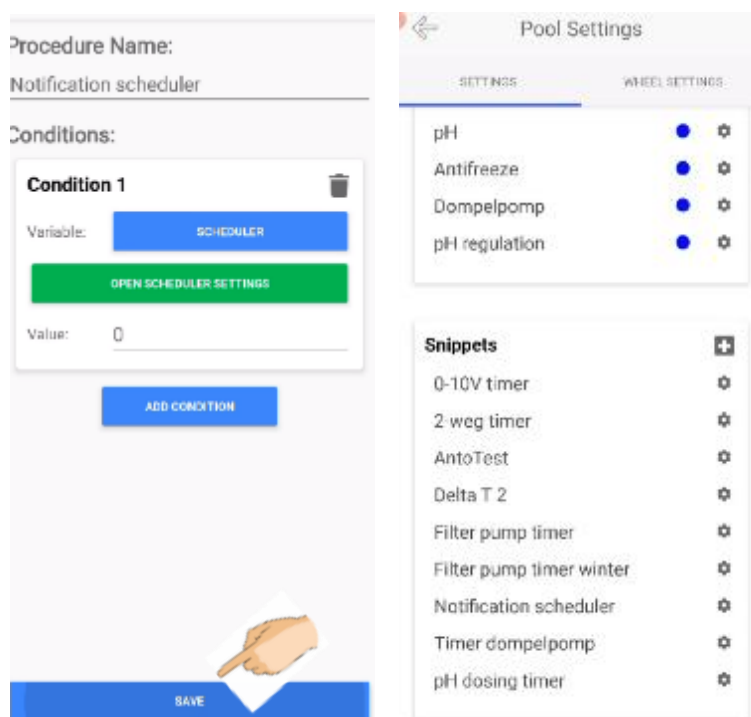

Adding alarm notification.

Make sure you also add an alarm notification in the manually entry itself.

6. In automations press the plus icon tab manual automation entry. Change the procedure name (e.g. pH > 9 alarm) and press “select device”.

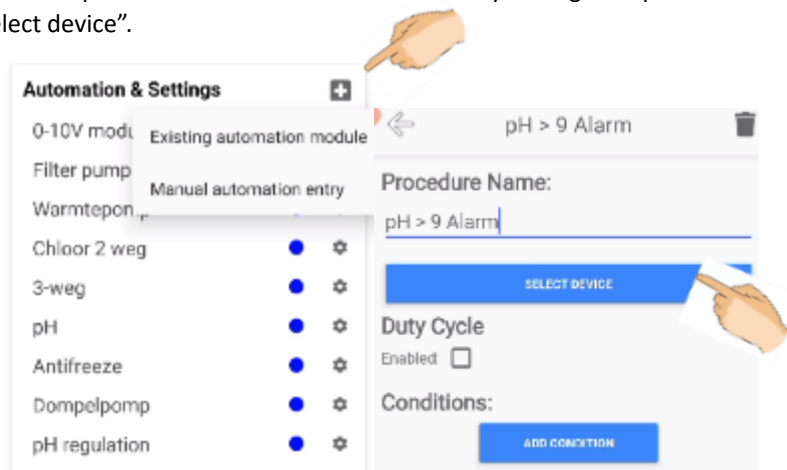

7. In select open “Alarm notification”. And change alarm message (e.g. pH > 9). Make sure to tab “add condition” and select, for example, your pH module.

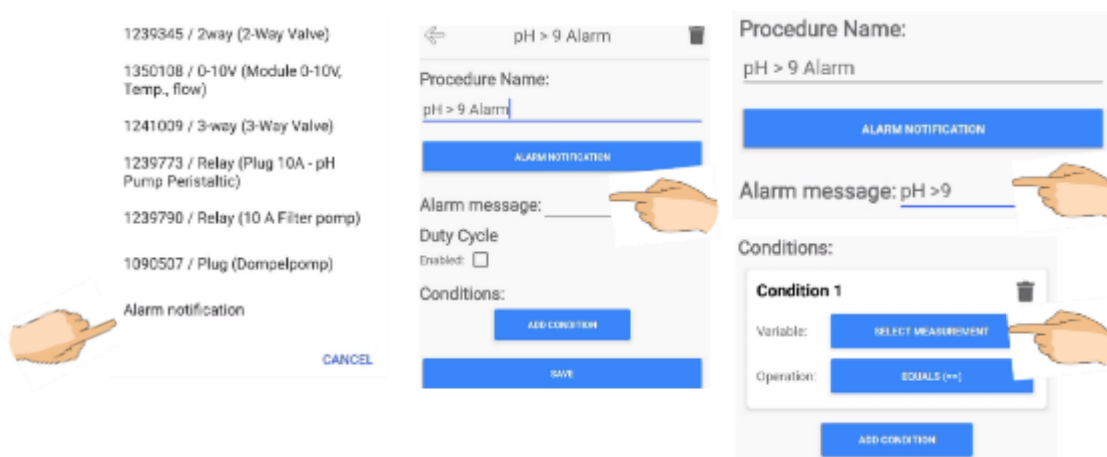

8. In here you can modify your operation and value.

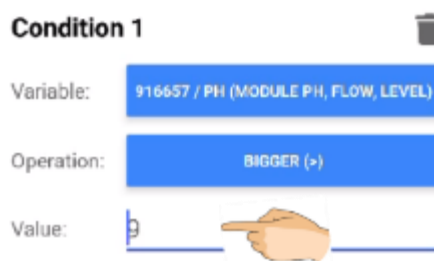

9. Finally press save.

3.5. Wheel Setting

Via the wheel setting page, you will be able to modify how the wheel on the main page looks like. You can choose icons, change the order, decide what you see and don't see in the wheel.

Via the wheel page, you can access the graphs pages.

As a special feature, you will be able to set the « fail safe » of your action devices.

You can access the wheel settings page via 2 routes :

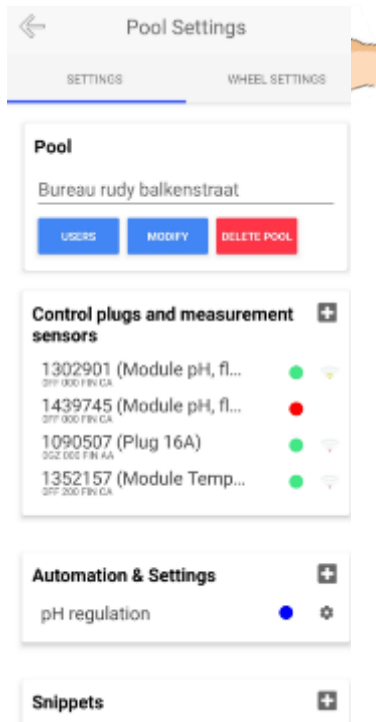
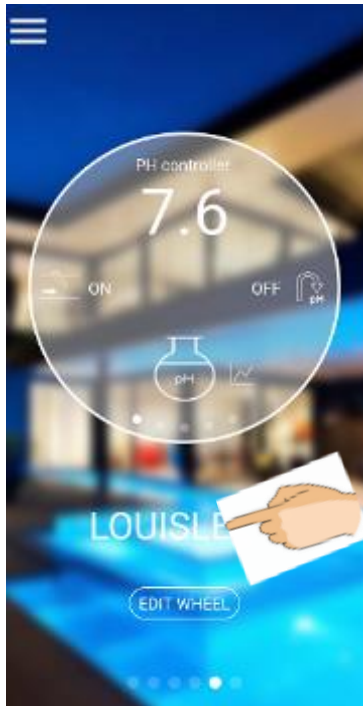

On Android phones

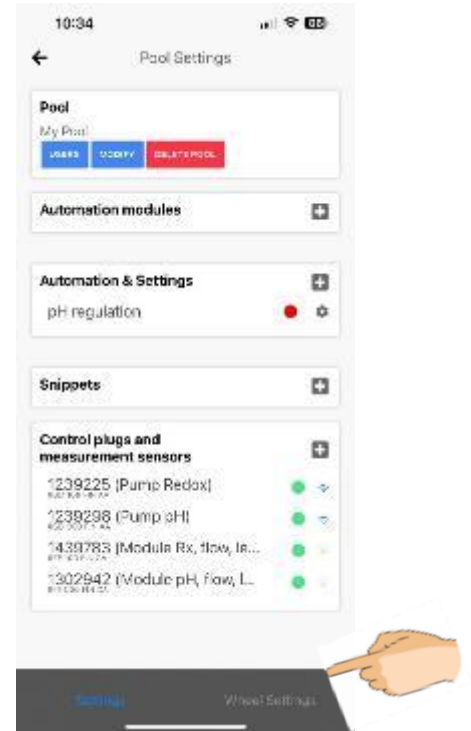

On iPhones

In the wheel, 3 variables are visible. By tapping the arrows, you can scroll through the pool variables displayed on the wheel. By tapping the graph symbol, you will see the graphical display of the last hour / 24H/3 days / week.

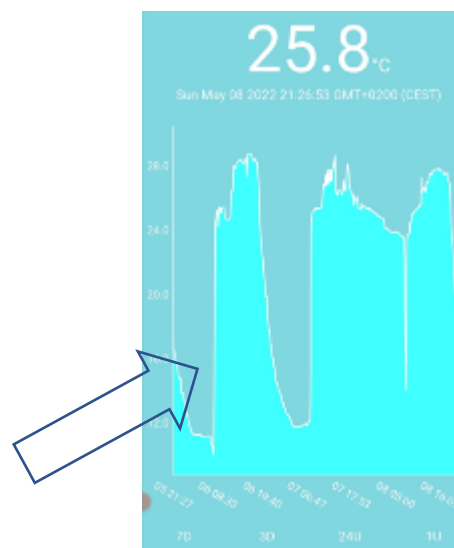
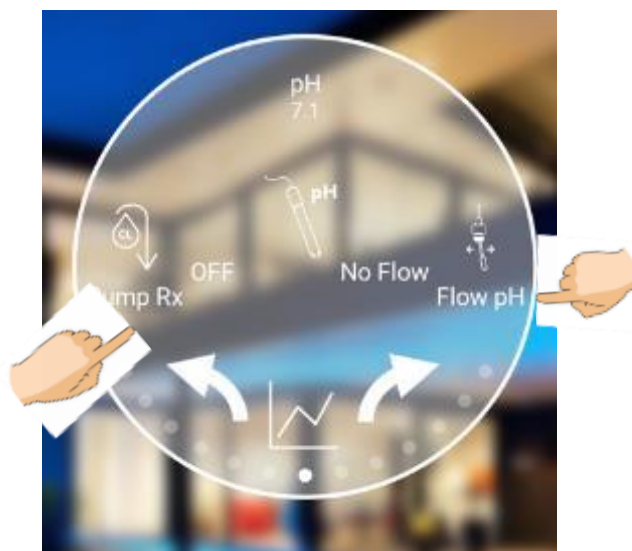

3.5.1. Wheel editing

Drag the items you want to make visible on your wheel dashboard from not visible to visible, by grabbing and dragging the 3 thin lines (sometimes you will need to hold your finger 3 seconds before dragging) at the right corner of your device. Make the reverse operation to make “invisible” items visible.

Moving items up or down within the visible zone, will change the order in which the devices are displayed on the wheel

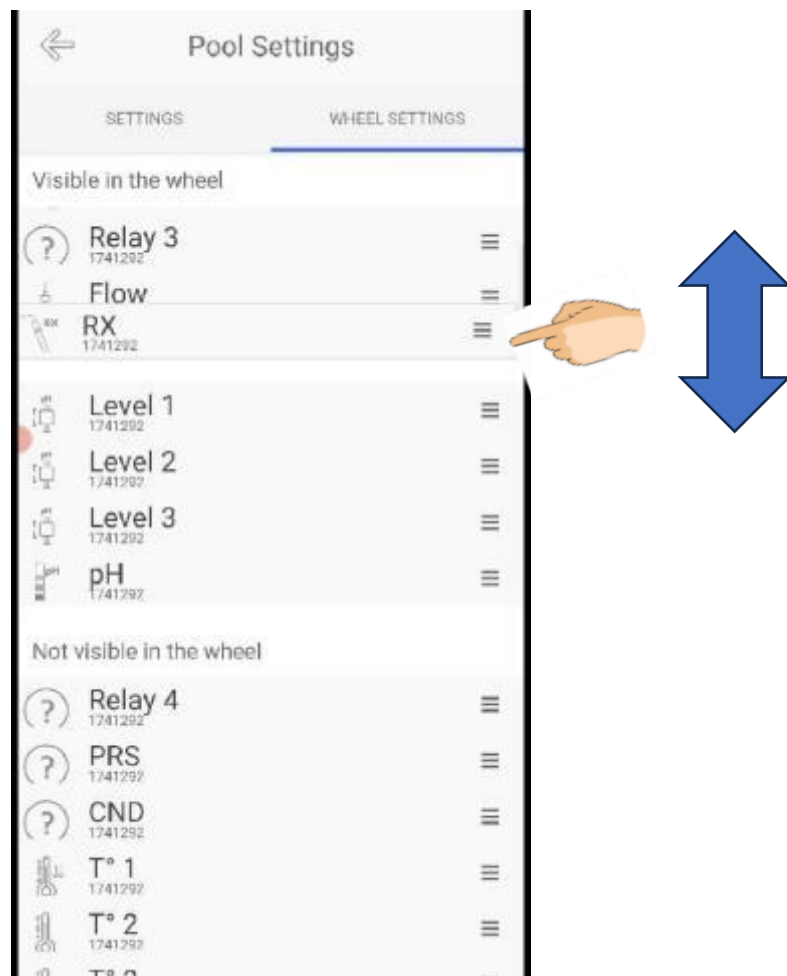

3.5.2. Icon selection

Tap on the device name in the “Wheel setting” page.

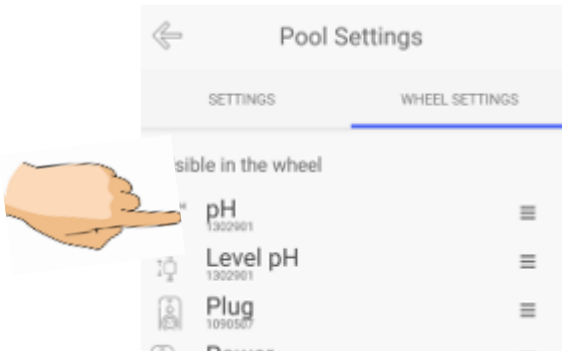

Select your favorite icon for your device. Go back by clicking on the top left corner arrow

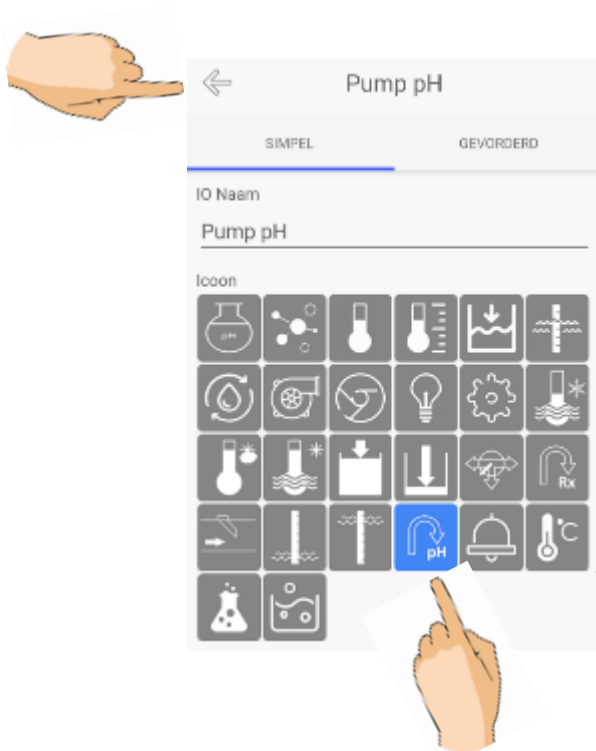

3.5.3. Failsafe mode

The Failsafe mode is used to define, what the device has to do in case wifi (or other) connection is lost : stop working or continue to work.

The failsafe mode can only be set for “action devices” such as plugs ,smart switches, pumps and automatic valves and not for measurement boxes.

To enter the failsafe menu, tap on the name of the device name once, followed by “advanced”.

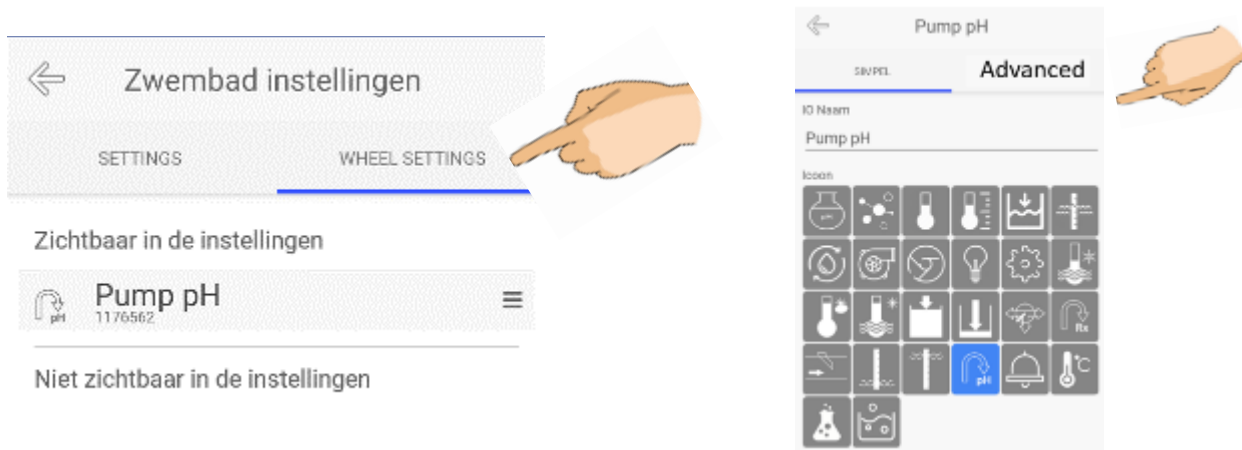

On the safety mode page, we can enter value 0 or 1.



At a failsafe setting of 0, the plug or smart switch will turn OFF during a system failure (e.g., loss of Wi-Fi). This setting is suitable for devices like a pH peristaltic pump. During a Wi-Fi loss, the pump needs to stop pumping.

At a failsafe setting of 1, the plug or smart switch will turn ON during a system failure (e.g., loss of Wi-Fi). This setting is appropriate for a winterizing filter pump, programmed to operate when outside temperatures drop below 2°C. If Wi-Fi is lost, the pump needs to continue running to prevent freezing.

Caution = be aware of the risk when switching failsafe on or off.

Example: set the pH dosing pump to failsafe 1, can cause pH- to be pumped nonstop to your swimming pool when internet connection is lost

The failsafe mode can only be set for “action devices” such as plugs ,smart switches, pumps and automatic valves and not for measurement boxes.

3.6. Action devices : Plugs and switches

Gen 2

In gen 2, there are no plugs or switches bur relays built right into the device itself. The Gen 2 connects straight to its power supply, as well as the pH pump and RX pump, making everything simple and straightforward.

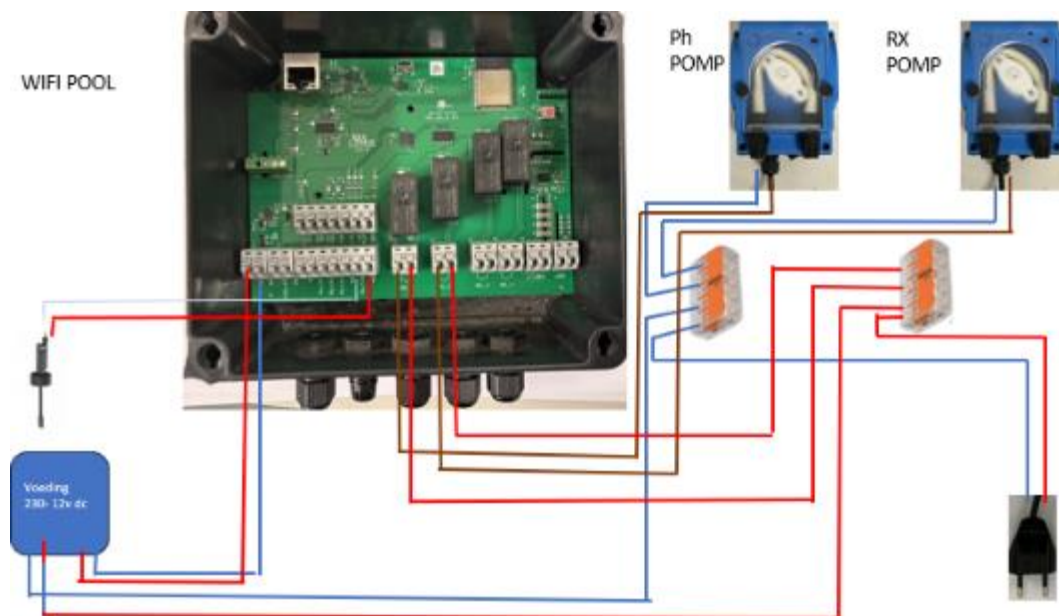

Gen 1:

Action devices, are devices with which you can start, stop, activate or deactivate a piece of equipment.

The Wifipool products are compatible with Shelly action devices, but only when the Wifipool software has been injected in the shelly devices

3.6.1. Plugs



Control plug 16A



Control plug 10A

The plugs operate on 230V

These plugs and switches will allow a pool equipment, such as a filter pump, UV lamp, peristaltic pump etc. to switch on or off. They are excellent for retrofitting existing equipment (such as a filter pump, peristaltic pump, lighting etc.) in the Wifipool app.

The plugs measure the power consumed.

3.6.2. Smart switches



Smart switch 16A



Smart switch 16A



Smart switch Plus 2 PM

Depending on the smart switch, they operate on 12, 24 and/or 230V.

These switches will allow pool equipment, such as a filter pump, UV lamp, peristaltic pump etc. to switch on or off. The Shelly smart switch 2 PM is used to switch a piece of equipment (e.g. an automatic valve) between position A and B. In some cases you will find these switches “hidden” in the Wifipool equipment.

Only the “red” smart switch; measures the consumed power.

The smart switches need to be connected to the pool equipment as follows :

Connection with on-off switch
For smart plug ZWPX0010

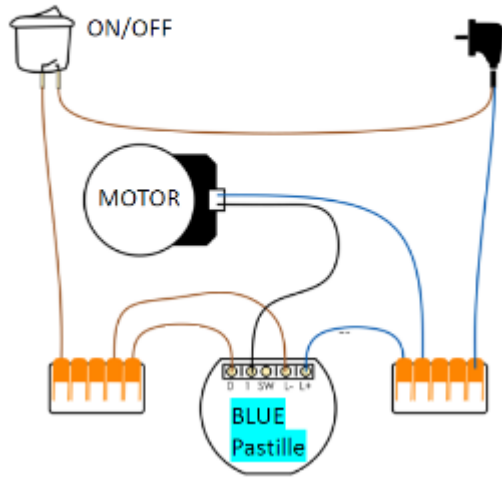

Connection without on-off switch
For smart plug ZWPX0010

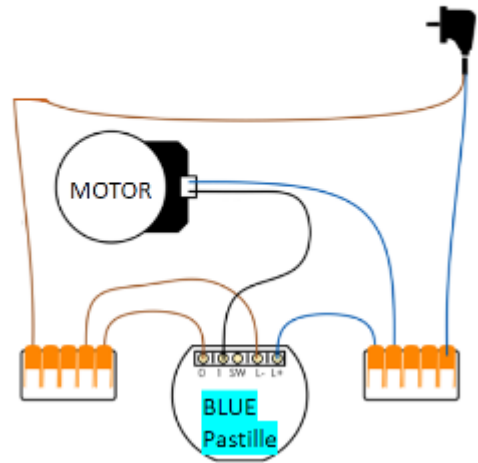

Connection with on-off switch
For smart plug ZWPX0020

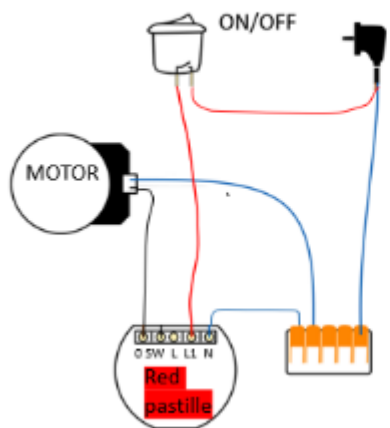

Connection without on-off switch
For smart plug ZWPX0020

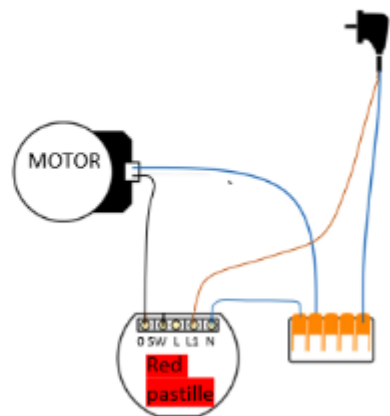

Equipment dependant
open/close connections

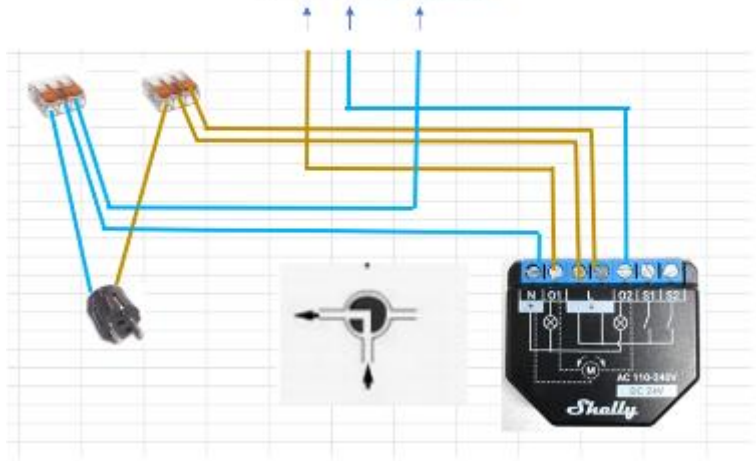

For the Shelly 2PM module,
the exact wiring depends on
the specific product.

3.7. Measurement devices

3.7.1. pH, RX and Temp

Our system contains 3 measurement boxes



pH, level, flow



Redox, level, flow



Temperature (x2), level, flow (TLF)

The units operate on a 5V USB plug, and consume less than 1 Amp.

The pH and RX probes have a regular and standard BNC connection

Level switch, flow switch and temperature probes have a male/female 3 or 2 pole water-tight Higo connection which are color coded so no mistake is possible.

These measurement boxes will allow you to measure various pool characteristics, which will be displayed on the mobile phone. Via the automation menu, it will be possible to steer the plugs and smart switches, depending on the measurements.

When adding a new measurement (flow or level switch) : disconnect the measurement box from the power, plug in the sensor, and connect to the power while the sensor is off position (no flow, low level)

For the temperature measurement box, it is necessary to plug in the measurement probes, before connecting the box to the power. If you see that the outside temperature and water temperature are "switched", then unplug the temp unit from the power, switch the temperature probes and plug the temp module into the power.

3.7.2. Combined measurement and control devices

3.7.2.1. 0-10V and 4-20mA

The 0-10V and 4-20mA modules contains both a “action” part and a “measurement part”

The modules can emit a constant voltage between 0 and 10V, or a constant current between 4 and 20mA. The modules can be used to control a external device.

The frequency regulator is controlled by applying a voltage to the regulator, where 0V = 0 rpm and 10V = 2950 rpm.



Both modules have one flow and two temperature measurement connections.

3.7.2.2. All-in Gen 2 – 2024

In gen 2 there are no more plugs and switches to worry about. Now, everything you need is built right into the device itself.



In a Gen 2 equipment , there are following measurements :
pH, RX, temperature (x3), level (x2), flow, pressure and conductivity (salt content).

There are 4 relays which can control 12-240V powered devices.

Additionally, Gen 2 introduces new connectivity options. Alongside Wi-Fi pairing, there's now Ethernet pairing available. While Wi-Fi is an option, it's important to note that the company prefers Ethernet connections. In the event of Wi-Fi issues, users may be subject to charges, so it's recommended to utilize Ethernet for optimal performance.

Not only is Gen 2 more connected, but it's also quicker to install. In previous generations, users had to scan each module separately during setup. However, with Gen 2, only one barcode needs to be scanned, and it's ready to go. This streamlined process minimizes installation time and hassle, getting users up and running faster than ever before.

Moreover, Gen 2 comes equipped with preprogrammed automations, further enhancing its user-friendly nature. These built-in automations simplify tasks and workflows, providing added convenience and efficiency for users. With Gen 2, automation is at your fingertips, ready to streamline operations and maximize productivity.

4 Problem Solving

4.1 Resetting your Wi-Fi equipment

After a “miscommunication” between cloud and device, it may be necessary to reset your device. To reset your smart plug you have to follow the Reset Procedure.

Gen 2:

To reset your Gen 2 WiFiPool device, please follow these detailed steps:

1. Open the Lid: Start by carefully opening the lid of your WiFiPool device. This will give you access to the internal components.
2. Locate the Red Button on the PCB: Once the lid is open, locate the red reset button on the printed circuit board (PCB). It is essential to identify this button correctly to proceed with the reset process.

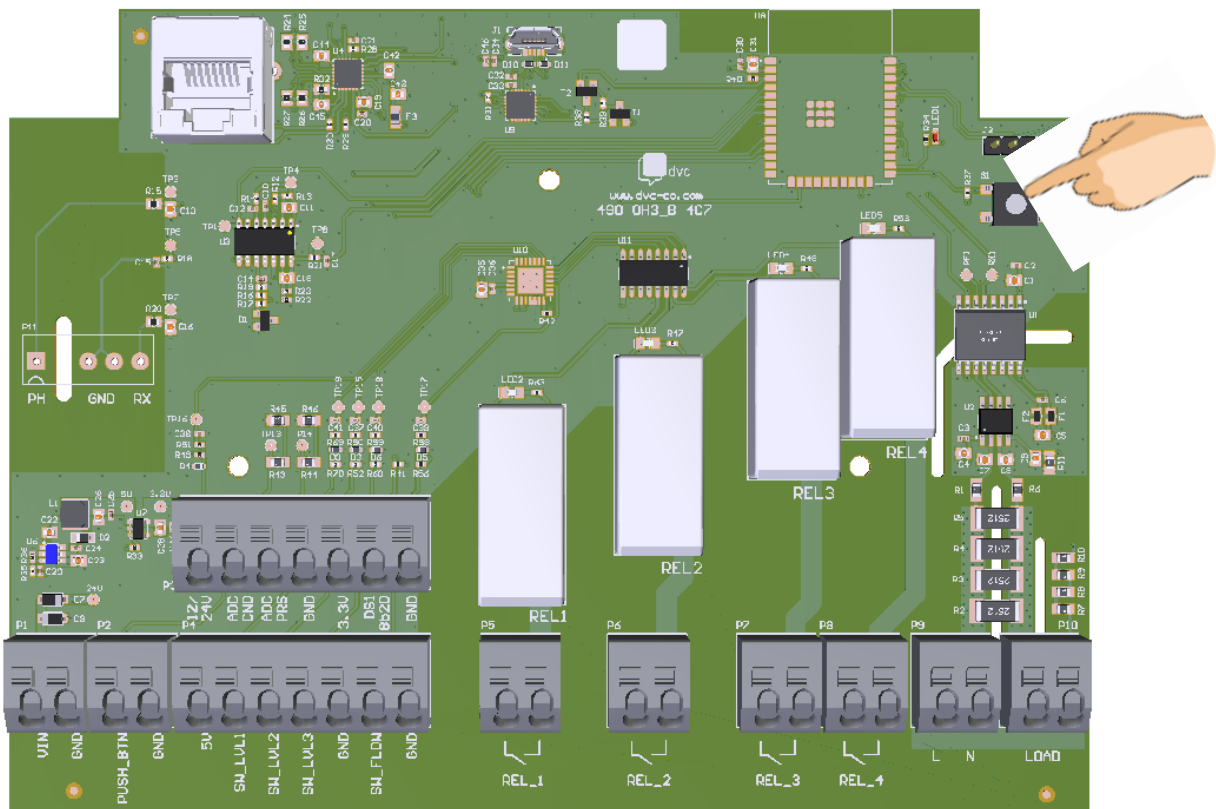

3. Hold the Reset Button: Press and hold the red reset button for exactly 40 seconds. Use a timer or a stopwatch to ensure that you hold the button for the full duration. Timing this step accurately is crucial for a successful reset.
4. Verify the Reset: After holding the reset button for 40 seconds, release it and observe the device. The reset process should now be complete.
5. By following these steps, your WiFiPool device should be successfully reset and ready for use.

Gen 1:

- Plug your smart plug in the outlet
- Plug out the USB for 10 sec
- Plug in-out the plug 7x

1. Plug your USB briefly in (1sec) and then pull out your USB for 2 Sec
2. Plug your USB briefly in (1sec) and then pull out your USB for 2 Sec
3. Plug your USB briefly in (1sec) and then pull out your USB for 2 Sec
4. Plug your USB briefly in (1sec) and then pull out your USB for 2 Sec
5. Plug your USB briefly in (1sec) and then pull out your USB for 2 Sec
6. Plug your USB briefly in (1sec) and then pull out your USB for 2 Sec
7. Plug your USB in and leave it in on the 7th time



Repeat 7 X



The same procedure applies also for the smart plug



Repeat 7 X



... procedure correctly than y... app and scan for devices : your phone will be searching for the plug.

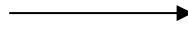
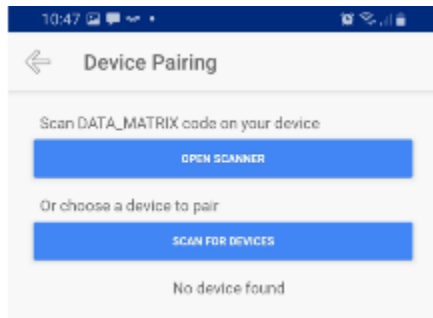

4.2 Notifications do not arrive consistently

On most devices, an app has background processes that allow it to do things like get notifications, which will remain active even when the app is closed.

Certain manufacturers (including OPPO & Xiaomi) have made their own versions of Android for their devices, so that notifications are not forwarded or only occasionally.

Fortunately, the settings that ensure that the app cannot forward notifications can be adjusted. The following article explains how you can make these adjustments for various devices (including of course OPPO) and thus hopefully receive the notifications as expected: <https://help.pushwoosh.com/hc/en-us/articles/360028478751-Android-device-cannot-receive-push-notifications-when-an-application-is-force-stopped-killed->

4.3 Pairing

Pairing problems have been addressed above

4.4 Contact troubleshooting

For troubleshooting, contact your supplier or contact info@beniferro.eu .

To make sure you can be helped efficiently, make sure info@beniferro.eu has become a user level co-owner of your pool (see section 3.1.1.2)

Appendices

Appendix 1: Preprogrammed Automations

In Gen 2, automations occur automatically after pairing your device. These are already set up by the system upon installation.

You can view the preprogrammed automations in "Automation & Settings". Most of these preprogrammed automations are based on conditions that work for most pools. Automations ensure that your modules are activated when certain conditions are met. For example, if your pH level is above 7.6, then your pH pump will start, or when there's flow or no flow, high or low redox levels, etc.

You can manually modify these automations or add your own. To modify the automations, tap on the automation title, and in the menu, you can adjust the conditions to your preferences. Only modify these settings if you understand what you're doing.

To create new automations, simply tap the plus icon and follow similar steps to modification as described in the previous paragraph.

For Gen 1 devices, preprogrammed automations exist but these need to be scanned in via a barcode. See the quick start manual of the device purchased.

Appendix 2 : Pairing instruction sheet example

Pairing and automation Wifipool water treatment

Thank you for choosing our Wifi water treatment. For an easy and quick start, we recommend the following:

1 Install the wifipool app. Instructions for installing the app can be found in the attached Wifipool App Quick Start Guide and Simple Equipment.

2 Pair the device with your phone

It's best to do this indoors in an area with a good Wi-Fi network connection (the same network you'll use for your pool) and a modem with a network cable connection (ethernet cable)

3 Connect the Wifipool control box to your modem via a network cable (ethernet cable) and start pairing. If you want to pair over a Wi-Fi connection (not recommended), refer to the Wifipool App Quick Start Guide and Simple Equipment. Please note: Beniferro does not provide free support for pairing via Wi-Fi, if you have a device with a network cable connection

3.1: Go to the "Pool Settings" app page,
tap on the plus icon next to
"Sockets & Measurement Sensors".

3.2: Select "Scan" and scan this
barcode:



3.3: Select the Wi-Fi network you want to use for your pool equipment

Once pairing is complete, you can continue with or without a network cable. Without a network cable, a good connection to your Wi-Fi network is required.

4 During pairing, automation was also loaded.

5 Once you've calibrated the pH and RX sensors, you're ready to use your device.

Appendix 3a : Gen 2 technical specifications

ETHERNET CONNECTION	Desired for pairing Possible for daily operation
STABLE WIFI	Required if ethernet cable is not available - standard extender or powerline compatible
WIFI CONNECTION PROTOCOL	802.11b, 802.11g and 802.11n
WI-FI RADIO FREQUENCY	2412 - 2484 MHz
WI-FI RADIO SIGNAL POWER	<1mW
WIFI DISTANCE OUTDOORS	up to 50 m outdoors and up to 30 m indoors (depending on the building materials)

PCB WITH ETHERNET CONNECTION – GEN 2	pH, RX measurement Extendible with Temperature measurement (x3), flow switch, level switch(x3), pressure measurement, conductivity measurement 4 ON-OFF relays 12-240V
TEMPERATURE SPECIFICATION	-20°C to + 70°C
CONFIGURATION	Via mobile phone (preconfigured)
AVAILABLE LANGUAGES	NL, EN, FR, DE, IT, ES
RELAY CONTROL	12-240V
POWER SUPPLY	12-240V(relai) 12 or 24V (PCB power)

Appendix 3 b : Gen 1 technical specifications

STABLE WIFI	Required - standard extender or powerline compatible
WIFI CONNECTION PROTOCOL	802.11b, 802.11g and 802.11n
WI-FI RADIO FREQUENCY	2412 - 2484 MHz

WI-FI RADIO SIGNAL POWER	<1mW
WIFI DISTANCE OUTDOORS	up to 50 m outdoors and up to 30 m indoors (depending on the building materials)

TEMPERATURE SPECIFICATION	-20°C to + 70°C
CONFIGURATION	Via mobile phone (preconfigured)
AVAILABLE LANGUAGES	NL, EN, FR, DE, IT, ES

ETHERNET CONNECTION	Desired for pairing Possible for daily operation
STABLE WIFI	Required if ethernet cable is not available - standard extender or powerline compatible
WIFI CONNECTION PROTOCOL	802.11b, 802.11g and 802.11n
WI-FI RADIO FREQUENCY	2412 - 2484 MHz
WI-FI RADIO SIGNAL POWER	<1mW
WIFI DISTANCE OUTDOORS	up to 50 m outdoors and up to 30 m indoors (depending on the building materials)

PCB WITH ETHERNET CONNECTION – GEN 2	pH, RX measurement Extendible with Temperature measurement (x3), flow switch, level switch(x3), pressure measurement, conductivity measurement 4 ON-OFF relays 12-240V
TEMPERATURE SPECIFICATION	-20°C to + 70°C
CONFIGURATION	Via mobile phone (preconfigured)
AVAILABLE LANGUAGES	NL, EN, FR, DE, IT, ES
RELAY CONTROL	12-240V
POWER SUPPLY	12-240V(relai)

12 or 24V (PCB power)



BENIFERRO.eu
plug & play products

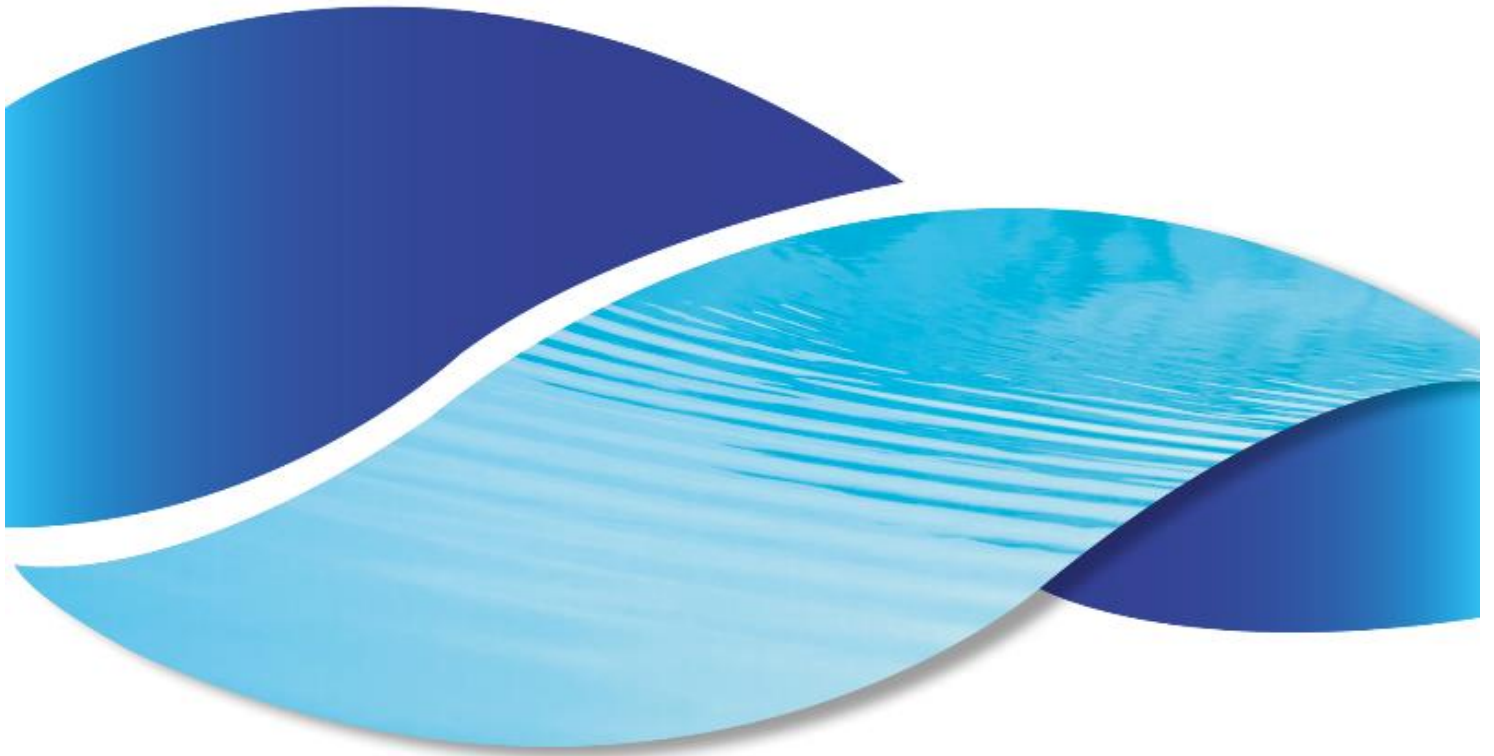

Wifipool App and Simple Devices – full manual



Contents

Introduction

1. The Wifipool app.....
 - 1.1. Introduction
 - 1.2. Installation of the app
 - 1.3. Changing your password, profile and privacy settings
 - 1.4. 1.4 Log out
- 2 Pairing.....
 - 2.1 What is pairing.....
 - 2.2 Problems with pairing.....
 - 2.3 Before pairing.....
 - 2.4 Pairing via ethernet connection.....
 - 2.5 Pairing via website.....
 - 2.6 Pairing via smartphone for IOS.....
 - 2.7 Pairing via smartphone of for Android.....
 - 2.8 Pairing trouble shooting.....
- 3 Using the Wifipool app.....
 - 3.1 Pool Settings
 - 3.1.1 Pool
 - 3.1.2 Control plugs and measurements
 - 3.1.3 Unpair
 - 3.1.4 Rename
 - 3.1.5 Calibration
 - 3.2 Automation & Setting
 - 3.2.1 Existing automation module
 - 3.2.2 Manual automation entry
 - 3.3 Snippets
 - 3.4 Wheel settings
 - 3.4.1 Wheel editing
 - 3.4.2 Icon selection
 - 3.4.3 Fail safe
 - 3.5 Action devices : Plugs and switches
 - 3.5.1 Plugs
 - 3.5.2 Switches
 - 3.6 Measurement devices
 - 3.6.1 pH
 - 3.6.2 RX
 - 3.6.3 Temp
 - 3.6.4 Control devices
 - 3.6.5 0-10V

3.6.6 Combined measurement and action devices

3.6.6.1 0-10V

3.6.6.2 All-in Gen 2 – 2024

4 Problem Solving

5 Appendices

5.1 Appendix 1 : automation barcodes

5.2 Appendix 2 : automation details

5.3 Technical specifications

Introduction:

The "Wifipool" app can be used to monitor and control your pool using the Wifipool Connect Pro Measurement and Control Box, smart plugs, and various sensors such as pH, Redox, and Temperature, along with associated accessories such as pH probes and temperature sensors.

To install and use the measurement and control box, you need to follow a series of steps:

- 1 Installing the Wifipool App
- 2 Connecting the Measurement and Control Box to the Wi-Fi Network and Phone
- 3 pH and RX calibration (if applicable) & automation



After completing these three steps, your device will be operational.

This manual describes the installation and use of the Wifipool app (step 1) and explains basic hardware functions (step 2)

The detailed specific operation of Wifipool filter pumps, water treatment modules, calibration and heating equipment are explained in the device manuals.

With Wifipool, it is possible to truly use one app for the control of your swimming pool.

We hope the product will contribute to a perfect pool control experience and great swimming pool pleasure

The Wifipool Team

1. The Wifipool app.

1.1.Introduction

The "Wifipool" app can be used to control your pool using the Wi-Fi pool measuring devices for pH and Redox, in combination with the Wi-Fi pool control devices such as smart plugs / smart switches, peristaltic pumps, and salt electrolysis.

The main page of the app features a wheel interface, displaying measurement values such as temperature, pH, etc. Swiping left or right on the wheel enables users to switch between multiple pools or create additional ones. **1** Tapping in the middle of the wheel or on the arrows allows users to toggle between different parameters of the selected pool, such as pH value, temperature, etc. **2** Tapping on the pool name redirects users to the pool's settings menu. **3** Selecting 'Edit Wheel' permits users to modify the content and order of the values displayed in the wheel.

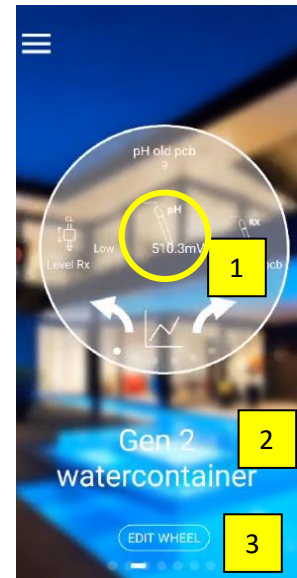

On the initial screen, **1** users can observe the status of your current value, whether it is on or off. Additionally, **2** there is a button for accessing statistics. Tapping the statistics button reveals how the current values are changing over time. **3** Two arrows, pointing left and right, facilitate navigation through the various pages. These pages include sections for pH, Rx, pH flow, and Rx flow.

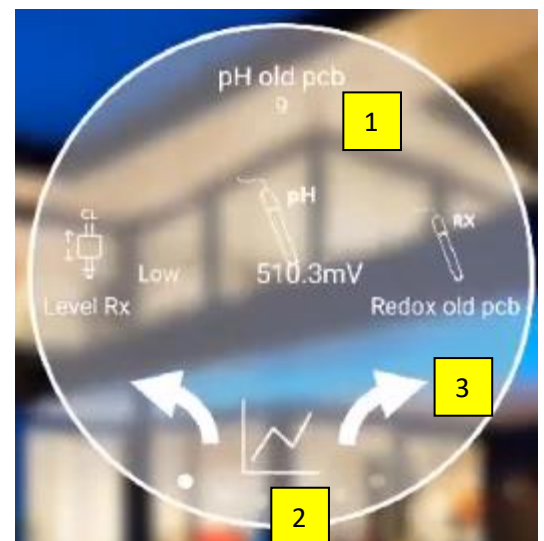

In addition to the Wifipool app, you need measuring boxes with accessories (probes, sensors etc.) to measure and display the pH, Redox, temperature etc. and smart plugs or other Wi-Fi pool control devices to turn your equipment on or off.



Before being able to use the app, you will need to install it. Then, you'll need to pair the Wifipool devices with your home Wi-Fi network and your phone. Finally, you will need to install the automations.

There are two versions of the Wifipool device: Gen 1 and, as of 2024, Gen 2. Gen 2 combines measuring and control devices on one PCB. Gen 1 operates via Wifi,, Gen 2 devices operate via Wifi and ethernet.





To connect the device, you first need to pair it to your phone and home network. Pairing via a ethernet cable is significantly more rapid and easier than pairing over Wifi.



1.2. Installation of the Wifipool application

1.2.1 Download the app

Android

1.  Go to the Google Play Store on your mobile device.
2.  Search for Wifipool
3. Click Download
4. Open the app and tab on the “Create one!” link. This will enable you to create an account. If you already have an account, you are not required to do so again. Continue following the instructions.

IOS (Apple)

1.  Go to the App Store on your mobile device.
2.  Search for Wifipool
3. Click Get
3. Open the app and tab on the “Create one!” link. This will enable you to create an account. If you already have an account, you are not required to do so again. Continue following the instructions.

1.2.2 Creating Wifipool Account

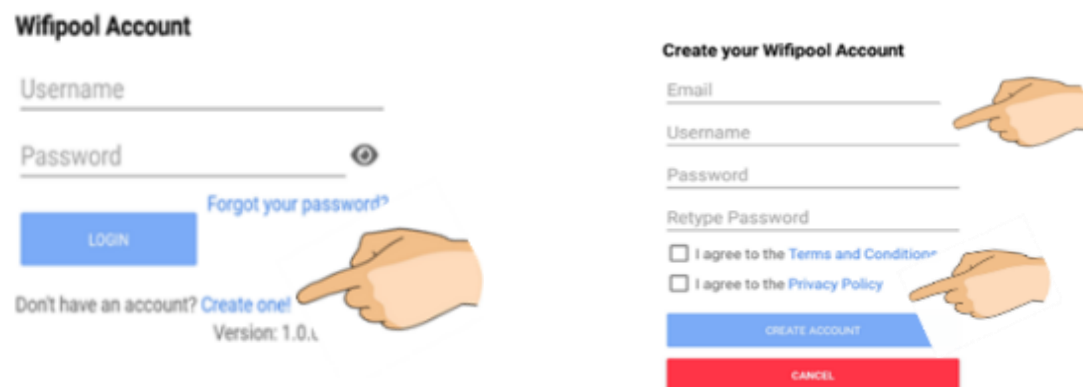

Wifipool Account

Username _____

Password _____ 

[Forgot your password?](#)

LOGIN

Don't have an account? [Create one!](#)

Version: 1.0.1

Create your Wifipool Account

Email _____

Username _____

Password _____

Retype Password _____

I agree to the [Terms and Condition](#)

I agree to the [Privacy Policy](#)

CREATE ACCOUNT

CANCEL

4. Enter your personal details and consent to the terms and conditions as well as the Privacy Policy to create a Wifipool account.
5. Press create account. The app will then send a verification email to your email address.
6. Proceed to your personal email account to confirm your email address. Check your 'spam' folder, as the email may end up there. If you haven't received an email, there might be a typing error in the email address or password. Consider trying to create the account again

1.2.3 Checking Wifipool version

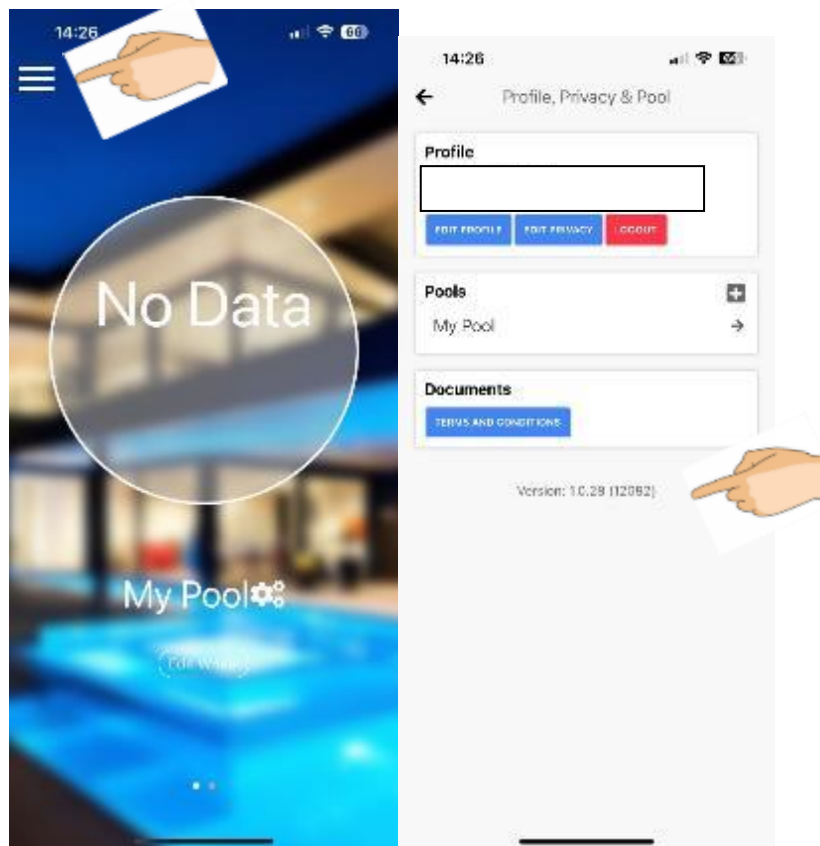

1. Always ensure you have the latest version of the app.
2. To do so, press \equiv in the top right corner of your screen.
3. This action will open the Profile, Privacy & Pool settings.
4. At the bottom of this screen, you will find the current version of the app.

Please note: The version displayed in the photo may not be the latest version of the app. Do not be alarmed if your version happens to be newer.

1.3.Changing your password, profile and privacy settings

Edit Profile and password

1. Click on the top left corner to go to the open the navigation bar and tab "Edit profile, privacy, logout".

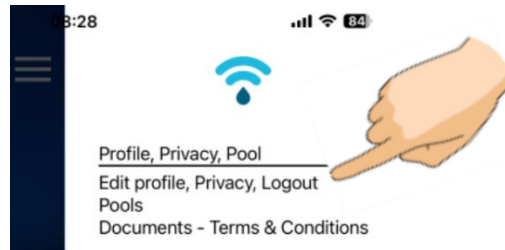
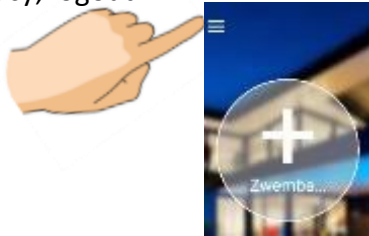

2. Click "Edit Profile"

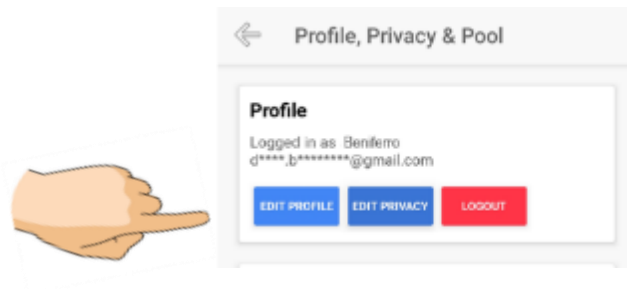

- 3 Change your personal information

- 4 Scroll down and click "Update" to confirm your changes

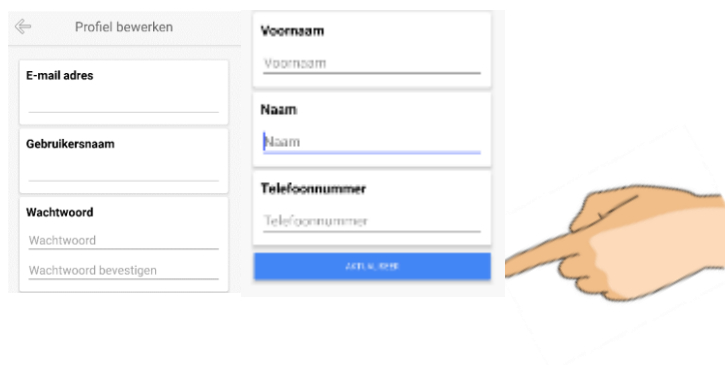

Privacy settings

1. Click on the top left corner to go to the open the navigation bar and tab “Edit profile, privacy, logout”.
2. Click "Edit Privacy"

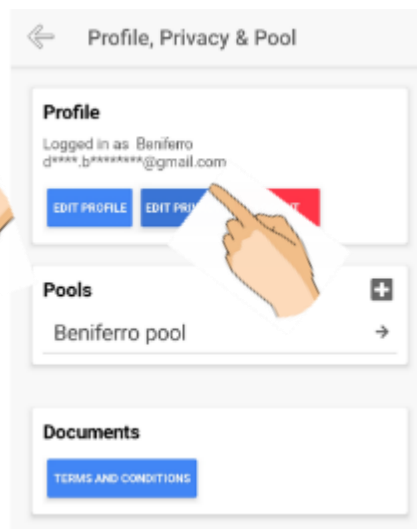
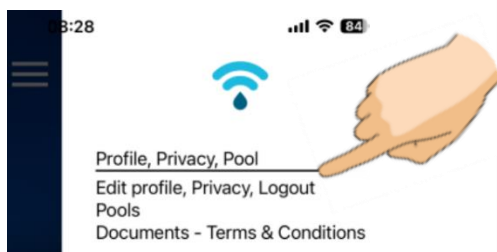
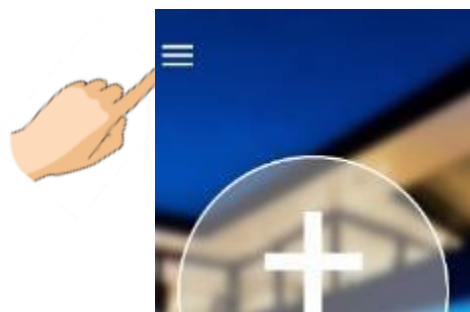

3. You can adjust your privacy settings by toggling the checkboxes.
4. Scroll down and click "Update" to confirm your changes



Please note: The above privacy settings may not display the complete list. They might not reflect the latest version. For the most up-to-date privacy settings, refer to the settings available on your phone.

1.4. Log out

1. Click on the top left corner to go to Profile, Privacy and Pool
2. Click "logout"

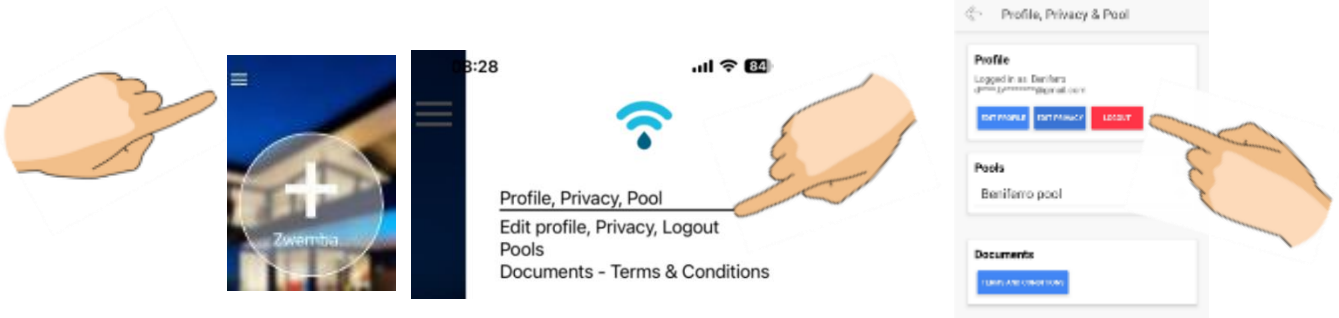

2 Pairing

2.1. What is pairing ?

Each Wifipool device emit a Wi-Fi signal. During the pairing process, we establish a connection between the Wi-Fi signal emitted by the Wifipool devices and the Wifipool cloud through our home network. We use our phone and ethernet connection (GEN2 only) to facilitate this connection.

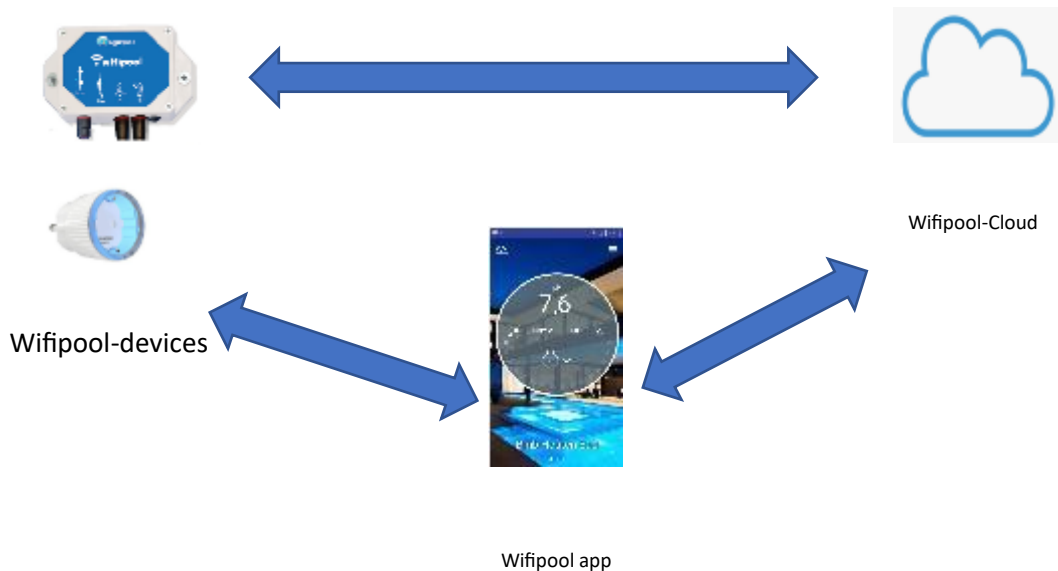

After pairing, the Wifipool devices will send data to the cloud, and they will receive instructions from the cloud. The communication occurs over the home Wi-Fi network and can be configured and monitored via the mobile phone.

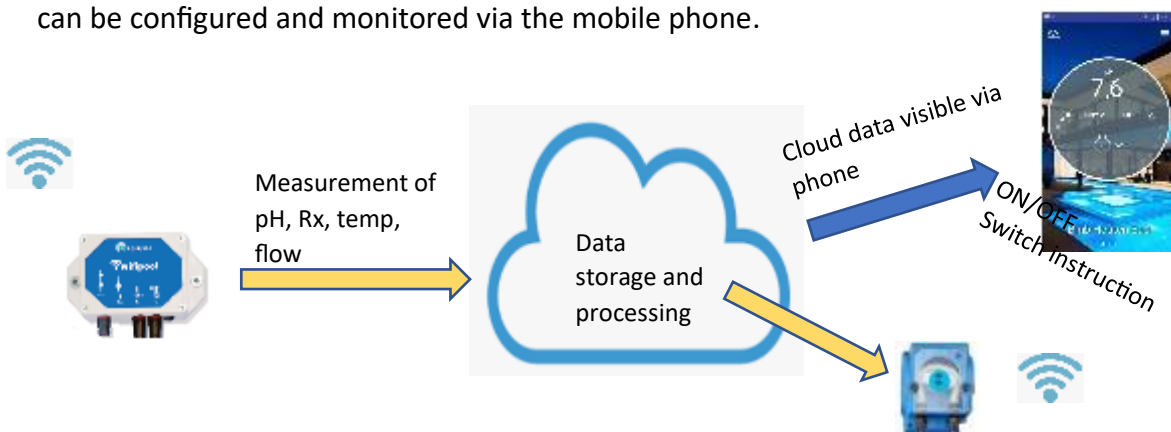

2.2. Problems with pairing

To ensure successful pairing, it's crucial to follow each step accurately. Both Android and iOS programmers have implemented intricate security measures, complicating the pairing process with several invisible security checks that must be confirmed.

The primary reason for pairing failures often stems from the instability of the home network. We strongly recommend conducting the pairing process indoors, close to the network source, and PRIOR to the physical installation of the devices. If you have a Gen2 Wifipool device, we recommend to pair via a ethernet connection.

Generally, pairing with Android proves to be easier compared to iOS. It's feasible to initially pair pool devices with an Android phone and then transfer ownership to an iOS device using the "Add user" feature (as mentioned above).

Once the pairing is complete, network stability becomes less critical. With Gen 2, these steps have been significantly streamlined, requiring only one-time pairing. Furthermore, it's not mandatory to pair via Wi-Fi; a cable connection is also an option, enhancing both the ease and reliability of the process.

2.3. Before pairing

If the board is not yet connected to a pool and no Ethernet connection has been established, the LED in the top right corner of the board will flash. In all other scenarios, it will not flash. This is the case when the board is already connected to a pool, either via Ethernet or WiFi. In this case, the LED will not flash, regardless of the type of connection (Ethernet or WiFi). It is important to note that if the LED on the board is flashing when the Ethernet connection is present, this does not mean that a connection to the Internet is available. If the Ethernet port is not flashing, no Internet connection is available.

Gen 1 (without) Ethernet

Led flashes when they are not paired and lights up 100% of the time after pairing. If they do not light up, they have no power, or the programming is wrong.

In previous generations, the red Shellys do not flash when they are not paired. However, the blue Shellys flash to indicate that they are ready to pair.

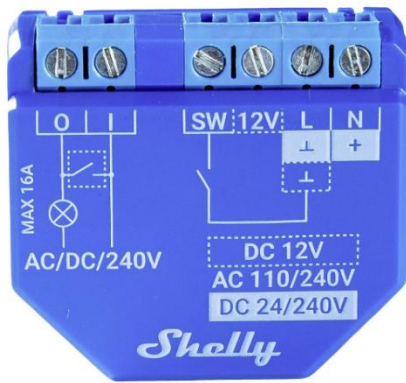

Both the small and the large plugs flash blue



First, ensure that the "Auto-join" feature in your Wi-Fi settings is activated. Without enabling this option on your smartphone, the network won't automatically reconnect, potentially causing issues when pairing your device. To activate this feature, navigate to the Settings app on your smartphone, then select "Wi-Fi" and tap the information ("i") icon. From there, toggle the "Auto-join" option to on, and proceed with the instructions below.

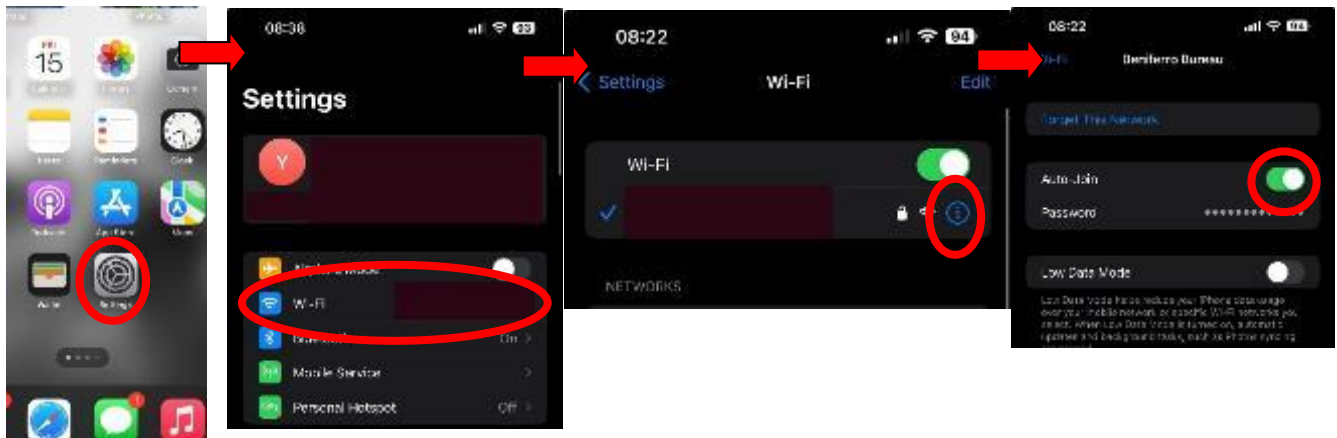

Before pairing with ethernet-connection:

1. Install the Wifipool app on your phone (as mentioned above).
2. Ensure you have an ethernet cable and connected to your device.



3. Make sure you have the instruction page (included with your order) with the device serial number and barcode. (See appendix 1).

Before pairing without ethernet connection:

1. Install the Wifipool app on your phone (as mentioned above).
2. Ensure you know the network names and password of your Wi-Fi network that you will use for your swimming pool.
3. Make sure you have the instruction page (included with your order) with the device serial number and barcode. (See appendix 1).

Additional Notes:

1. Take your time. The pairing process will take 5-30 minutes, depending on the number of devices to pair and the technique used.
2. Make sure the wifi products are used within the required technical specifications (see appendix 3), such as 2.4GHz wifi network, -20 to 70°C, dry environment, etc.
3. If the circuit board is not yet connected to a swimming pool and no Ethernet connection has been established, the LED on the top right corner of the circuit board will flash. In any other scenario, it will not flash. This applies when the circuit board is already connected to a pool, either via Ethernet or WiFi. In this situation, the LED will not flash, regardless of the connection type (Ethernet or WiFi). It is important to note that the flashing of the LED with the Ethernet connection on the circuit board is does not mea that a connection to internet is available. When the ethernet connector does not flas, no internet connection is available.

2.4.Pairing via ethernet

Pairing via ethernet is the preferred pairing method. The method is only available for Wifipool devices containing an ethernet connection, produced from 2024 onwards.

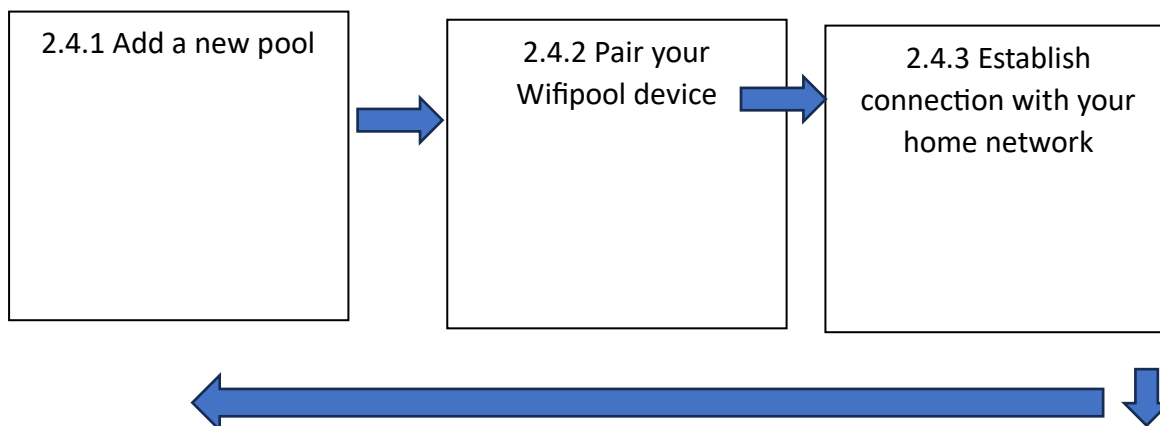

2.4.4 The device is added , automations are loaded and the phone returns to the Pool settings screen



2.4.5 Finalizing installation

2.4.1 Add new pool

Firstly, make sure you add a new pool, give it a unique name .

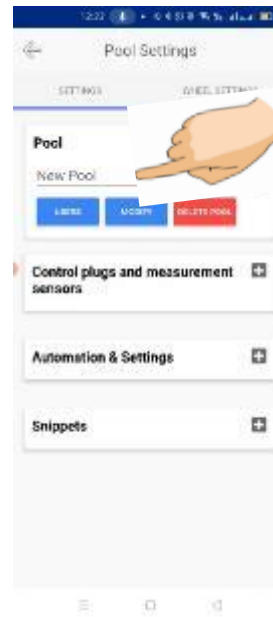
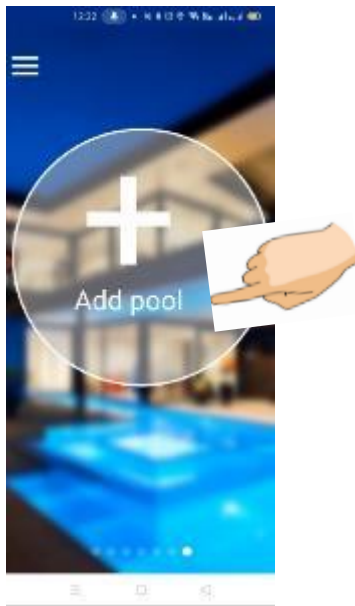

2.4.2 Pairing Wifipool device

Tap the plus icon next to "Control plugs and measurement sensors."

Always ensure that you connect your device using an Ethernet cable to establish a stable connection. If your router flashes a light, it indicates that the connection is successful.

Then, where it says "Scan the bar or 2D (QR) code on your device," tap "Start scanning" and proceed to scan the barcode on your device or on the "Startup information sheet" included in the box.

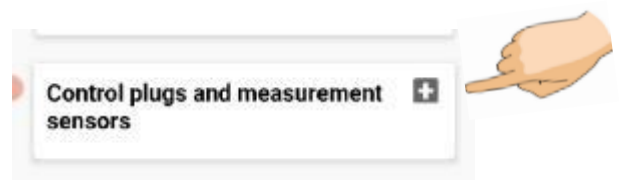

2.4.3 Connect to home network

The next step is different for Android vs IOS.

Android : you have to select your home network : the network which you will use for your swimming pool equipment.

IOS : You will have to enter the Swimming pool network name (SSID) and password manually.

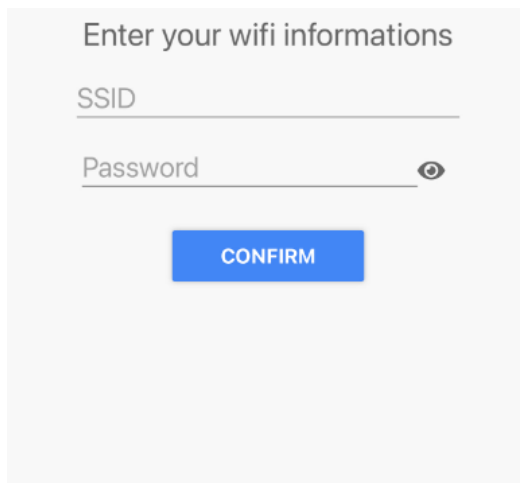
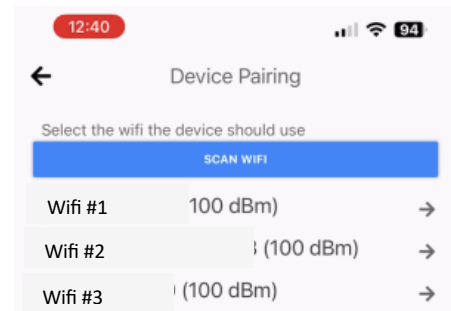
A screenshot of a web-based form titled "Enter your wifi informations". It has two input fields: "SSID" and "Password". The "Password" field has an eye icon to its right, indicating a toggle for visibility. Below the fields is a blue button labeled "CONFIRM".

Enter the correct password. Press the eye and check your password carefully, if you enter the wrong password, the app will go back to the main menu and your device will only remain connected as long as the device has ethernet connection. As soon as the ethernet cable is removed, connection will be lost.

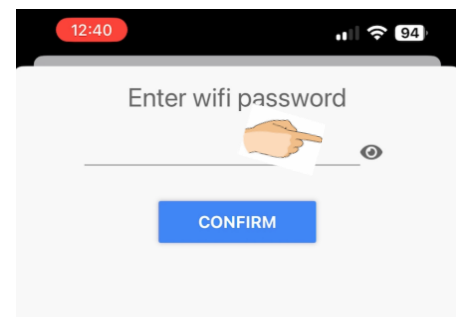

2.4.4 The device is added and the phone returns to the Pool settings screen

The app will return to the main screen. If not, close the app and open it again. A first device is now paired, and you will see the device in the Pool settings page.



2.4.4.1 Predefined Automation & Settings

With Gen 2, there may be predefined automation settings already configured. After installation, you can find them under "Automation & Settings." These settings are automatically activated once you start using them.

2.4.4.2 Wrong Wi-Fi password entered (ethernet)

In case your device is connected via ethernet, there won't be any error message if you have entered the wrong password. The menu will show a red signal next to your connection. Just unpair the device from the Wifipool app and go back to step 2.4.2



2.4.5 Finalizing installation

After the installation process is finished, go back to your pool settings.

Check if your control plugs and measuring modules are paired and functioning. If the indicator light turns green, it means they are paired. If it's red, it means there's (still) no connection. Always wait a moment until the indicator light turns green as it may take some time.

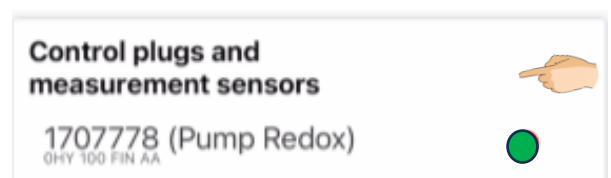

Note: Beniferro does not offer free technical support for pairing issues via Wi-Fi if you have an Ethernet device.

In case you have pH and RX probes, you need to calibrate your Wifipool device. This simple calibration process is explained in the quickstart manual of the equipment purchased

(More info about calibration, see chapter: Calibration) Once calibrated, you can seamlessly proceed with the physical installation of the device, ensuring optimal performance and accuracy in monitoring your pool's environment.

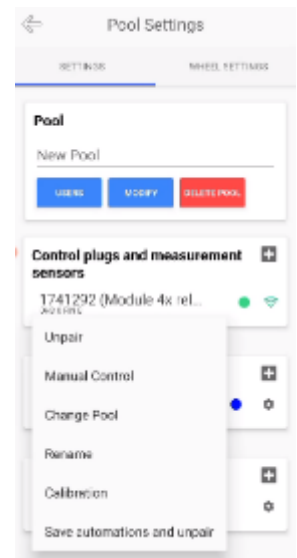

2.6. Pairing of the WIFIPPOOL-devices via Wifi for iOS devices.

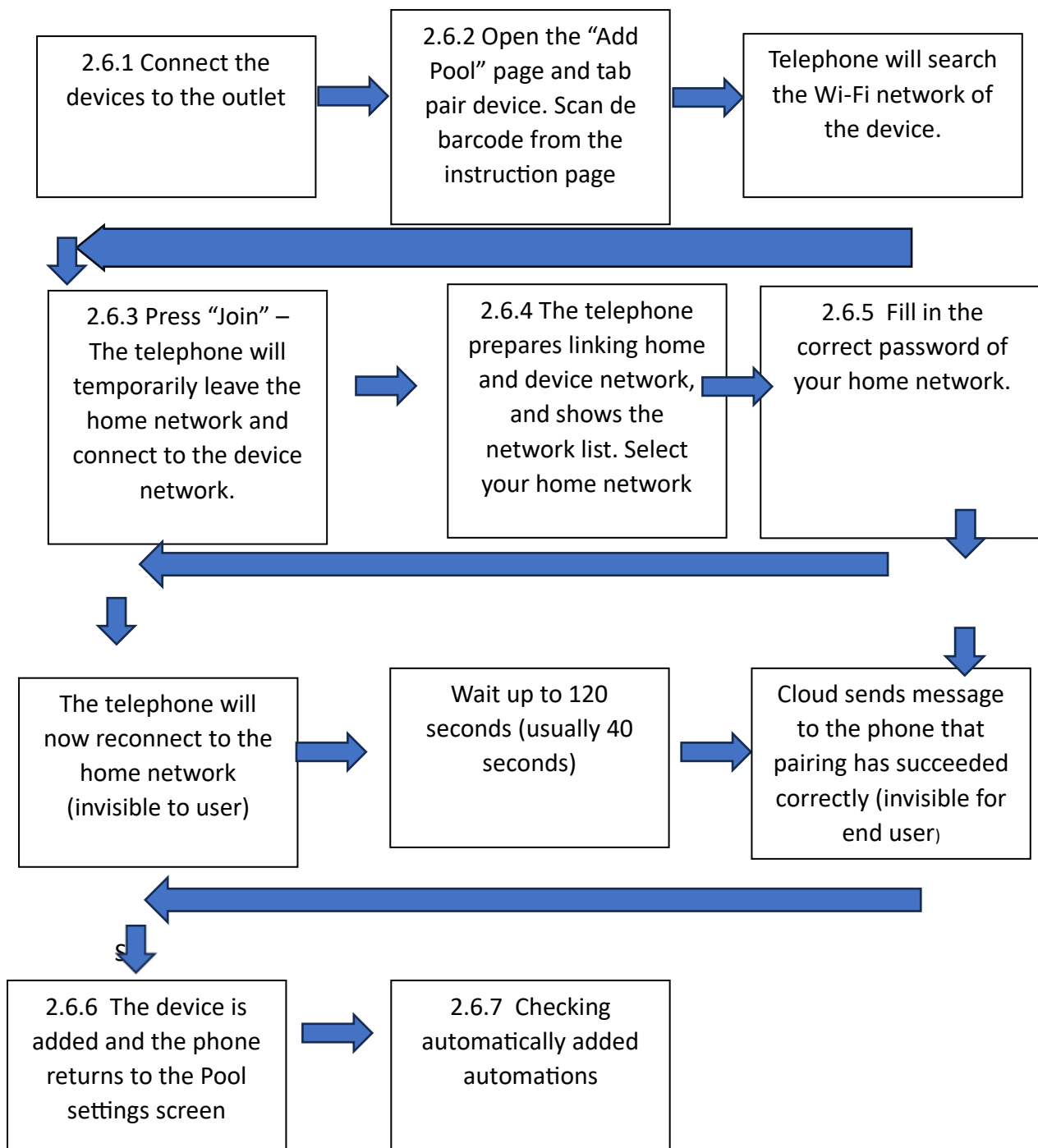

This pairing method is mandatory for Gen 1 devices (no ethernet connections) and is optional (but not recommended) for GEN 2 devices with ethernet connector.

The pairing needs to be completed for all the devices, before the pool automation can be entered into the system Please note: The manufacturer does NOT give free support for this pairing process if pairing via ethernet of webpage are available for your device.

2.6.1 Connect the devices to the outlet

After connecting the power, the Wifipool devices will emit a Wi-Fi signal. You will see the SSID of the devices in the available Wi-Fi list of your phone. The SSID is a combination of 6 and 4 letters/digits

In this example, there is a SSID for a pH pump, a salt electrolysis, a pH measurement and a Redox measurement.

Please note: If everything is paired successfully, you will no longer see these devices in your Wi-Fi settings

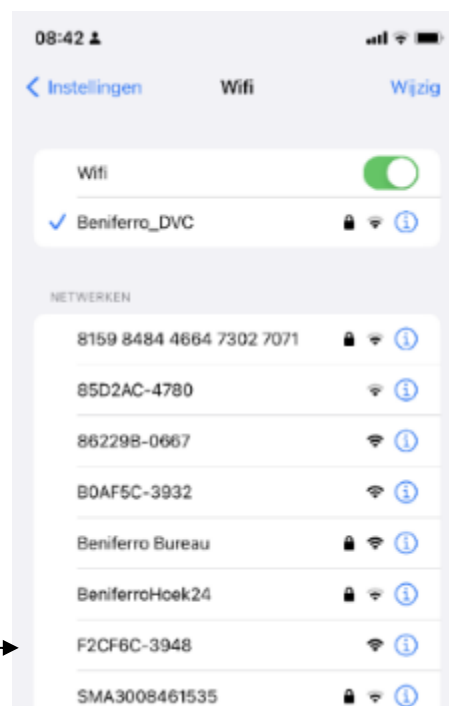

2.6.2 Connect the devices to your phone one by one. To do this, go to the pool settings on the Main screen and tick the Pool name (1), and press 2 on the "Control Plugs and Measurement Sensors" section and press + (press 2). Scan the first barcode on the instruction sheet that came with the products you purchased.

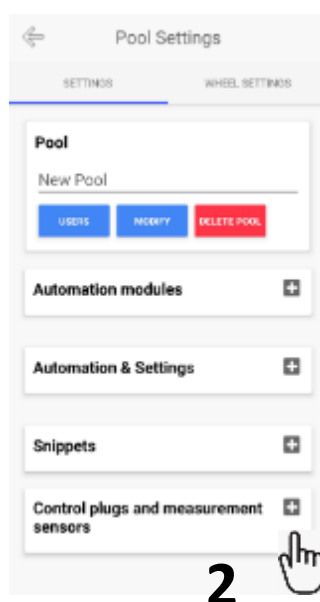

Start scanning



2.6.3 Press “Join” – The telephone will temporarily leave the home network and connect to the device network.

After scanning, a short notification will be displayed indicating that the Wi-Fi pool device is being connected to the phone.

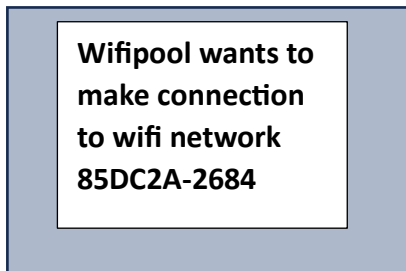

The app will start searching for your WiFi networks, your device would no longer show the WiFi icon at the top right for a short moment.

2.6.4 The telephone prepares linking home and device network, and shows the network list. Select your home network : the network which is most active around your pool.

2.6.5 In the next step you have to select your home network : the network which you will use for your swimming pool equipment.

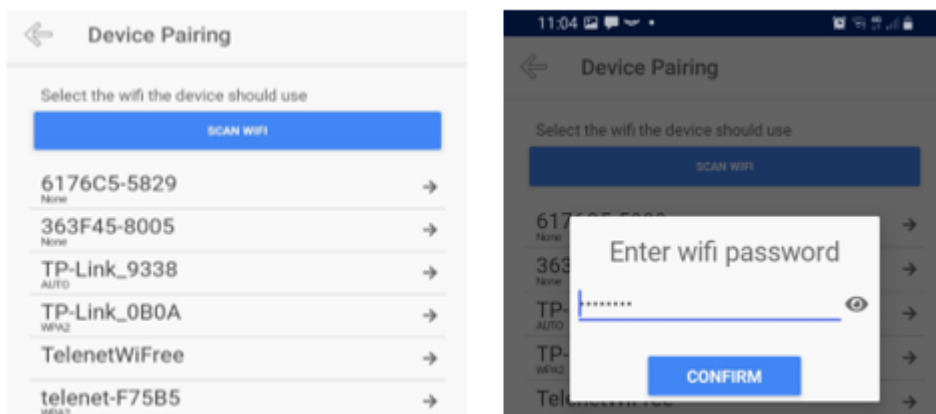

Enter the **correct** password Press the eye and check your password carefully, if you enter the wrong password, the app will go back to the main menu and show the following message: "The pairing process has failed".

The wrong password will now be saved, so if you reuse the saved password on a next attempt, the attempt will fail again.

If the correct password is entered, the phone will now start searching for the network and start the pairing process. During this period, do not interrupt the system, do not move the devices or the phone. Just be patient and wait. It takes usually +- 40 seconds to complete the process, but on other occasions it may take up to 120 seconds.

The last step of this process is a communication from the cloud to your phone (message not visible for end user), that the pairing process was successful.

2.6.6 The device is added and the phone returns to the Pool settings screen



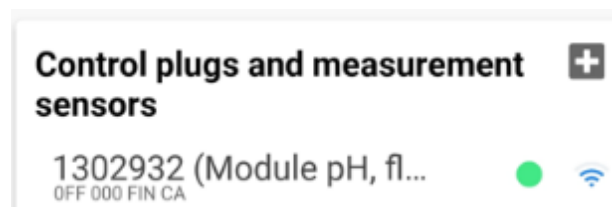



The app will return to the main screen. If not, close the app and open it again. A first device is now paired, and you will see the device in the Pool settings page.



2.6.7 Connect remaining devices

Repeat steps 2.6.1 to 2.6.6 until all devices are paired. You will now see your devices in the Pool settings page. A red circle behind the device indicates the device is not connected to the Wi-Fi. A green circle means the device is connected.

Control plugs and measurement sensors

1302901 (Module pH, fl... OFF 000 FIN CA		
1439745 (Module pH, fl... OFF 000 FIN CA		
1090507 (Plug 16A) OGZ 000 FIN AA		
1352157 (Module Temp... OFF 200 FIN CA		

2.6.8 Checking automatically added automations

Ensure to first verify whether any preprogrammed automations (appendix 1) are already present. This may be the case if you just paired a Gen 2 device. These will conveniently appear under the section titled "Automation & Settings". Should you find that there are no automations listed, take the initiative to manually incRXorate them by scanning the provided barcodes. This step ensures comprehensive control and optimization of your device's functionalities. See the quick start-up manual of the equipment purchased.

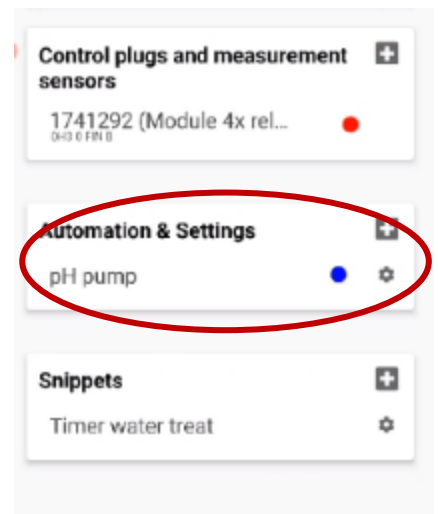

a. Pairing the WIFIPPOOL devices via WIFI on a Android phone

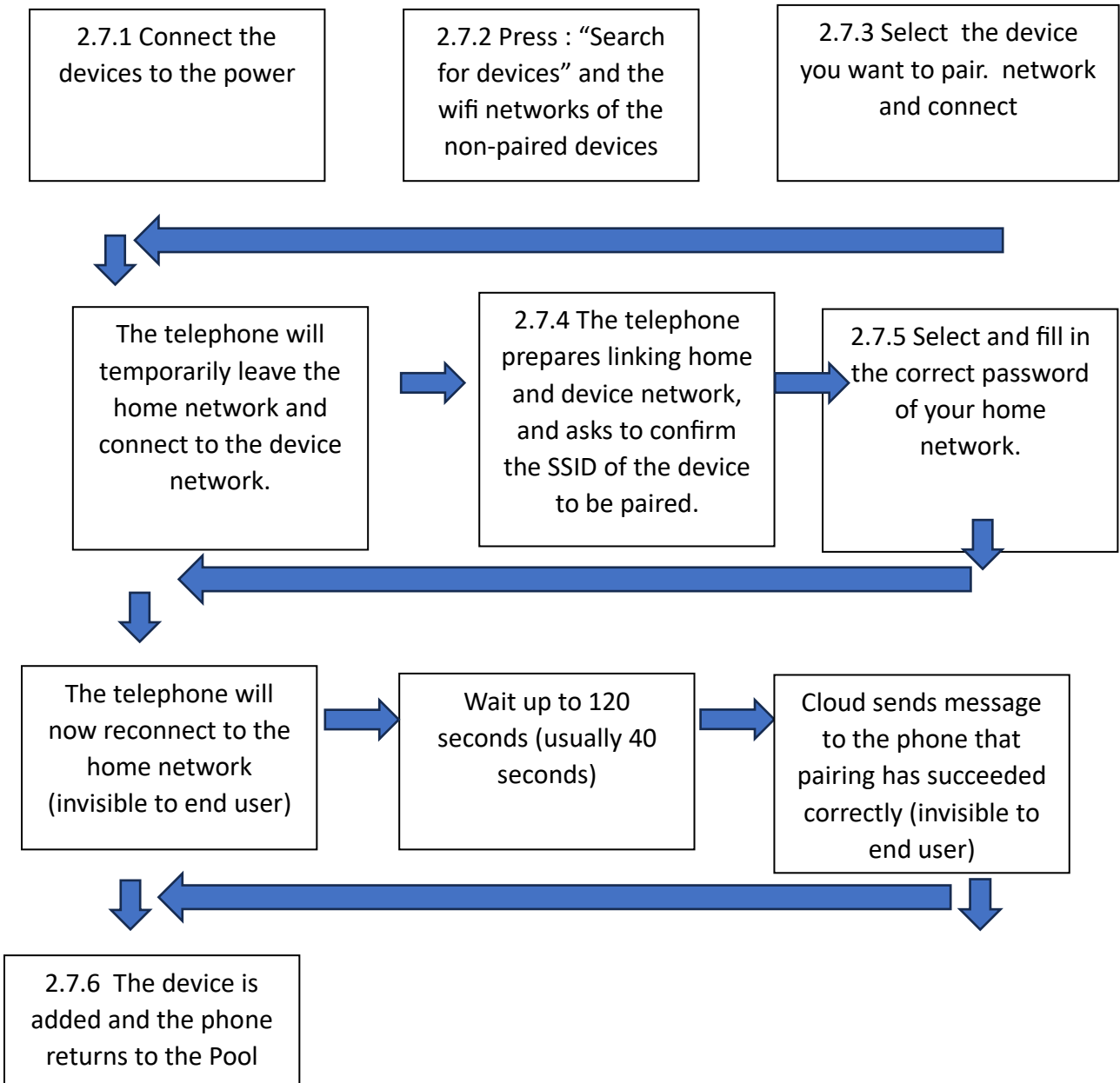

The pairing needs to be completed for all the devices, before the pool automation can be entered into the system

Attention : The manufacturer does NOT give free support for this pairing process if pairing via ethernet or webpage are available for your device.

2.7.1 Connect the devices to the power

After connecting the power, the Wifipool devices will emit a Wi-Fi signal. You will see the SSID of the devices in the available Wi-Fi list of your phone. The SSID is a combination of 6 and 4 letters/digits

- letters/digits
- In this example, there is a SSID for a pH pump, a salt electrolysis, a pH measurement and a Redox measurement.

Please note: If everything is paired successfully,

- you will no longer see these devices in your Wi-Fi settings

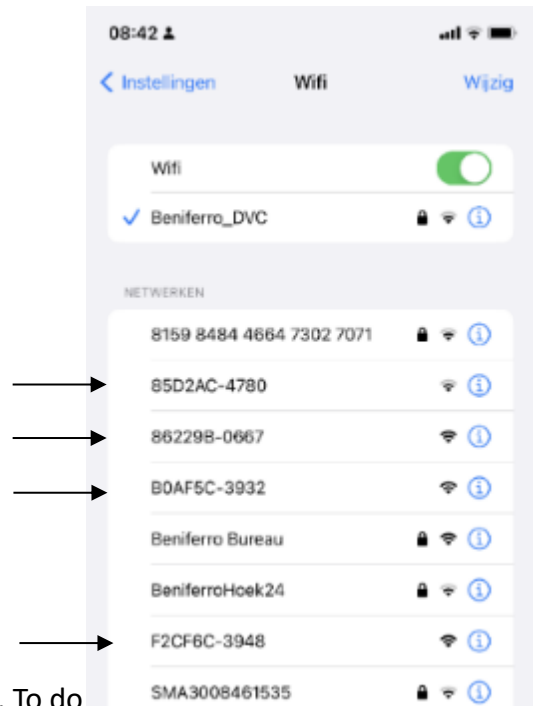

2.7.2 Connect the devices to your phone one by one. To do this, go to the Main screen and tick the Pool name (1), and on the "Control Plugs and Measurement Sensors" section press + (2). Subsequently start the « search for devices »(3), and select the device you want to pair (4).

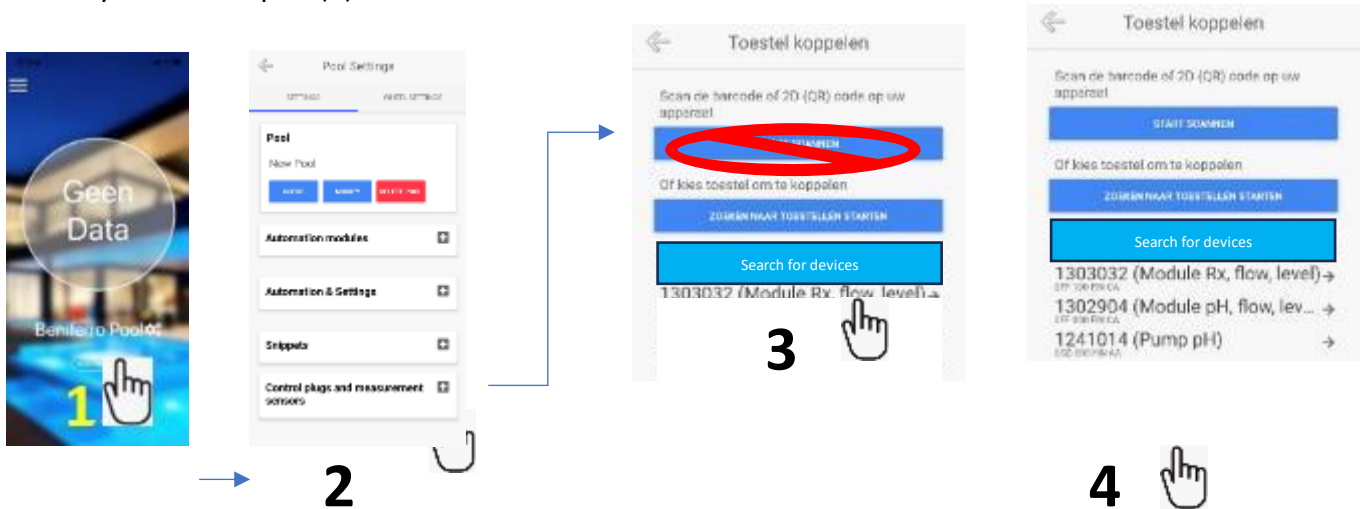

2.7.3 Press "Connect" – The telephone will temporarily leave the home network and connect to the device network.

2.7.4 The telephone prepares linking home and device network, and asks to confirm the SSID of the device to be paired.



2.7.5 In the next step you have to select your home network : the network which you will use for your swimming pool equipment.

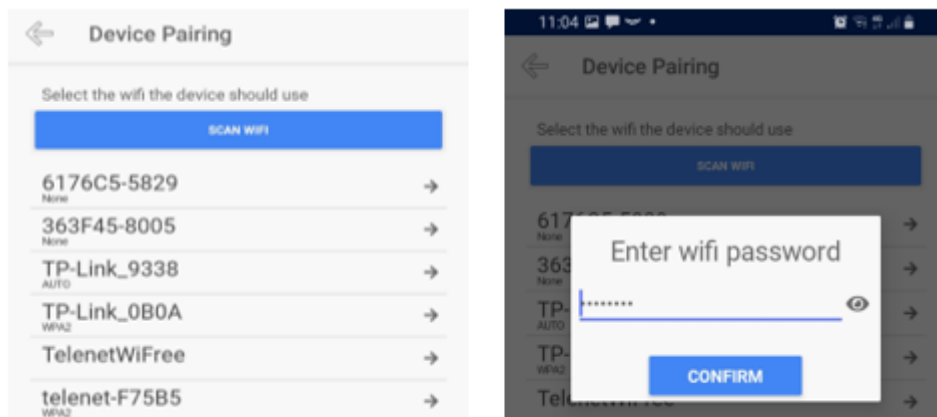

Enter the **correct** password Press the eye and check your password carefully, if you enter the wrong password, the app will go back to the main menu and show the following message: "The pairing process has failed".

If the wrong password is entered and saved, subsequent attempts with the same password will also fail. However, if the correct password is entered, the phone will initiate the network search and begin the pairing process. It's crucial not to interrupt the system during this period or move the devices or phone.

Please be patient and wait. Typically, this process takes approximately 40 seconds to complete, but in some cases, it may take up to 120 seconds. The final step involves a

communication from the cloud to your phone (a message not visible to the end user) confirming that the pairing process was successful.

2.7.6 The device is added and the phone returns to the Pool settings screen or to the main screen. If not, close the app and open it again. A first device is now paired, and you will see the device in the Pool settings page.

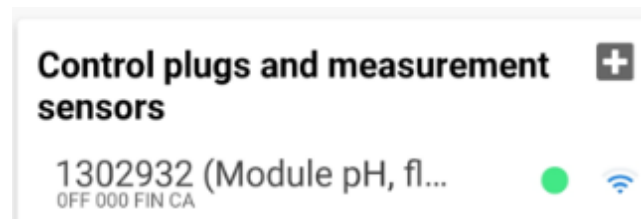

2.7.7 Connect remaining devices

Repeat steps 4.4.1 to 4.4.6 for each device until all devices are paired. Once paired, you will see your devices listed in the Pool settings page. A red circle behind the device indicates that the device is not connected to Wi-Fi, while a green circle signifies that the device is connected.

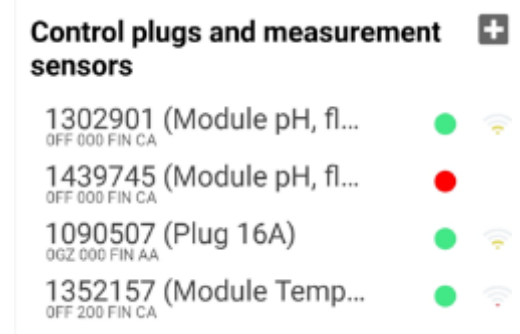

2.7.8 Checking automatically added automations

Ensure to first verify whether any preprogrammed automations (appendix 1) are already present. This is the case for GEN2 devices. These will conveniently appear under the section titled "Automation & Settings". Should you find that there are no automations listed, take the initiative to manually incRXorate them by scanning the provided barcodes. This step ensures comprehensive control and optimization of your device's functionalities. Barcodes and instructions are found in the quick startup manual of the device purchased.

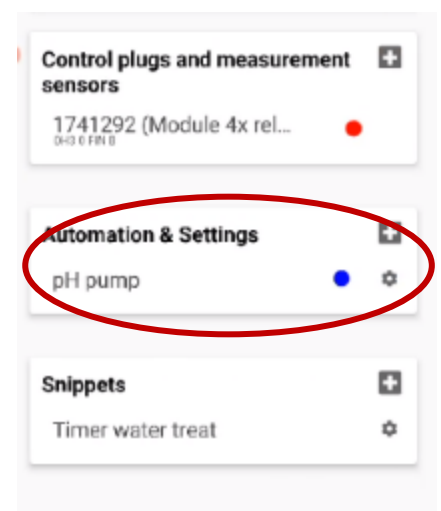

2.8 Pairing Problem solving IOS and Android

Step 2.6.6 / 4.5.6 Error: Wi-Fi connection failed - Possible causes:

- The home Wi-Fi network is not strong enough, unstable or absent in the zone in which you want to pair.

Solution for Gen 1:

Check that your phone is connected to your home network used for the pool. If not, select the appropriate network and ensure the phone remains connected during the pairing process.

Verify that the Wifipool network(s) in the format of 6 Characters/Digits - 4 Characters/Digits (e.g., 85C927-2343) is/are present in your phone's networks. Each unpaired device should display a network. After a power outage, it may take up to 3 minutes for the network to be visible.

If the device network is visible: Attempt to pair again from step 2.6.2.

If the device network is not visible, ensure the device is plugged in correctly (check the USB plug). If plugged in correctly, then reset the device by plugging and unplugging 7 times (each approximately 2 seconds). Wait until the Wifipool network is visible and your phone is connected to the correct home network, then attempt pairing again in the strong network zone from step 2.6.2.

If the error persists, contact your supplier after reading the section: 'What to do if I need to contact the supplier?'

Solution for Gen 2:

Check that your phone is connected to your home network used for the pool. If not, select the appropriate network and ensure the phone remains connected during the pairing process.

Verify that the Wifipool network(s) in the format of 6 Characters/Digits - 4 Characters/Digits (e.g., 85C927-2343) is/are present in your phone's networks, or for gen 2 devices, there can be more characters/digit – 9 digits and 4 characters (e.g., 975C93534-3850) . Each unpaired device should display a network. After a power outage, it may take up to 3 minutes for the network to be visible.

If the device network is visible: Attempt to pair again from step 2.6.2.

If the device network is not visible, ensure the device is plugged in correctly (check the USB plug). Unplug the device and wait 40 seconds and plug it back in. Wait until the Wifipool network is visible and your phone is connected to the correct home network, then attempt pairing again in the strong network zone from step 2.6.2.

If the error persists, contact your supplier after reading the section: 'What to do if I need to contact the supplier?'"

There is no assistance for WiFi connection problems, so pairing via ethernet is recommended

Step 2.6.6 / 2.7.6 Error: Pairing failed

Possible causes:

The home and/or device Wi-Fi network isn't strong enough or absent from the zone where you want to pair. Make sure your phone is near both home Wi-Fi and device Wi-Fi. Best is to do the pairing in-house before installing the pool equipment.

Solution:

1 Wait another 60 seconds after seeing the error message and verify if the device is not paired after all. If so, you will see your device on the Pool Setting page.

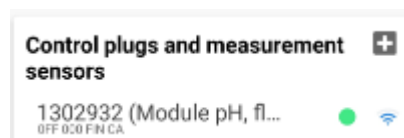

2. Check that the Wifipool network(s) in the formats 6 Characters/Digits - 4 Characters/Digits - For example, 85C927-2343 is/are present in your phone's networks. For each unpaired device, a network is visible. After a power outage, it takes up to 3 minutes for the network to be visible.

If the device network is visible : Try to pair again from step 2.6.2 / 2.7.2

If the device network is not visible, verify that the device is indeed plugged-in (also check that the USB plug is working correctly). If plugged in correctly, then reset the device by plugging in and unplugging 7 times (each +- 2 seconds). Then wait until you can see the Wifipool network and that your phone is connected to the correct home network, and try again to pair in the strong network zone from step 2.6.2 / 2.7.2

If the operation 7 times (each +- 2 seconds) has not worked, verify that the home network is indeed powerful at the location of the device. If the device is left for 15 minutes in the strong network zone to which it was paired (or partially paired), the device may reset itself.

If this error returns, contact your supplier after reading the section : What to do if I need to contact the supplier ?

Step 2.6.6 . 2.7.6 Error: Pairing Process failed - Possible causes:

Possible cause : The password you use for your home Wi-Fi network was entered incorrectly (and the wrong password was saved).

After a 120 minutes waiting time, a error message will display : The pairing process failed. Home network instability, or not strong enough in the pairing zone or too much distance between device, home network and phone.

Solution: Enter the password manually and verify the password when pairing the devices.

Step 2.6.6 / 2.7.6 : Error: "wrong password"

Issue 3: "Wrong Wifi password"

Possible causes:

1. You entered the wrong password
2. You switched the pairing methods from Ethernet to non-Ethernet

Solution:

1. Try pairing again and make sure to fill in the right password.
2. Reset the plug or the measuring box by disconnecting it from the power outlet for 30 seconds and then plugging it back in.

If you are connecting with Ethernet, make sure to plug in your cable before pairing. If you are connecting with Wifi, make sure there is definitely no Ethernet cable connected before pairing.

Step 2.6.2 / 2.7.2 : "Unable to connect to network 'Wi-Fi pool device name'

Possible causes:

The Wi-Fi pool device Wi-Fi network is not strong enough or absent in the zone in which you want to perform the pairing.

Your phone is too far from the Wi-Fi pool device



Solution:

1. Check that the Wifipool network(s) in the formats 6 Characters/Digits - 4 Characters/Digits - For example, 85C927-2343 is present in your phone's networks. For gen2 there can be more characters/digits. For each unpaired device, there is a network. After a power outage, it takes 3 minutes for the network to be visible.

If the network is visible: retry to pair from step 2.6.2 / 2.7.2 in a zone where all the networks (Wifipool networks and your home pool network) are strong.

If the device network is not visible, verify that the device is indeed plugged-in (also check that the USB plug is working correctly). If plugged in correctly, then reset the device by plugging in and unplugging 7 times (each +- 2 seconds). Then wait until you can see the Wifipool network and that your phone is connected to the correct home network, and try again to pair in the strong network zone from step 2.6.2

If the operation 7 times (each +- 2 seconds) has not worked, verify that the home network is indeed powerful at the location of the device. If the device is left for 15 minutes in the strong network zone to which it was paired (or partially paired), the device may reset itself.

If this error returns, contact your supplier after reading the section : What to do if I need to contact the supplier ?

Step b2 2.6.2 : Home Wi-Fi network is not visible

Solution: On iPhone the network screen doesn't always show up over the full length of the device. Scroll down the network list to check if you can see the network.

Step b2 2.6.2 : Wi-Fi network are not displaying correctly (undefined NaN dBm)

Solution: press the "scan Wi-Fi" button multiple times until your networks are accurately detected and displayed.

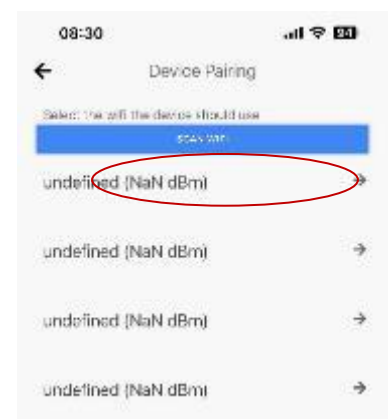

Step 2.6.2 / 2.7.2 : "The device cannot be paired because it is already connected to another pool"

Solution:

Check if you can see the device in the pool settings page . If this is the case, everything is fine.

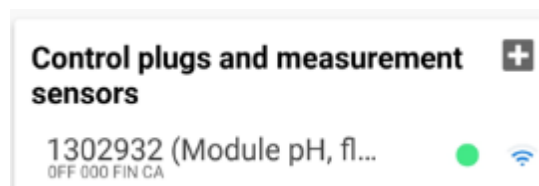
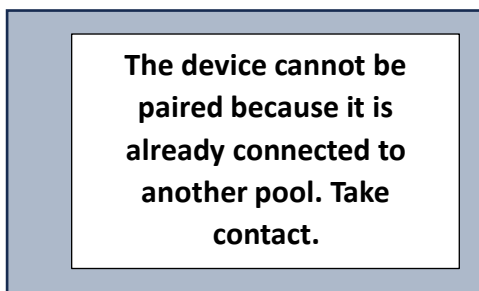

If the device network is not visible, verify that the device is indeed plugged-in (also check that the USB plug is working correctly). If plugged in correctly, then reset the device by plugging in and unplugging 7 times (each +- 2 seconds). Then wait until you can see the Wifipool network and that your phone is connected to the correct home network, and try again to pair in the strong network zone from step 2.6.2 / 2.7.2

If this error returns, contact your supplier. It can remotely perform an additional reset of the Wi-Fi pool device.

What to do if I need to contact the supplier ?

Please act as follows:

1. Plug in and out the devices that are not working
2. Please send a photo of the barcodes provided for pairing. These can be found on the Connect Go/Pro control box or on the pairing instruction sheet included with the delivery.



3. Send a screenshot with all your home networks. All devices should be shown on the screenshot.

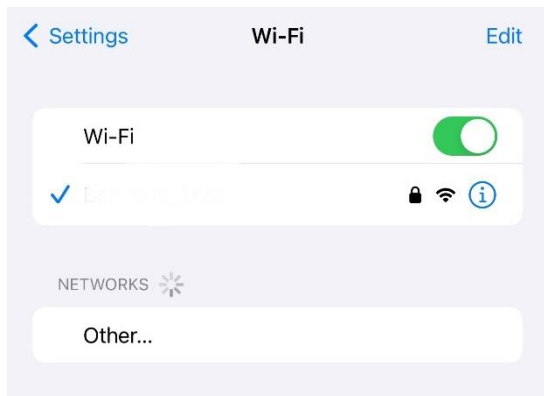

Please wait until all the networks are displayed, and then send a screenshot of the entire list.

4. Send a screenshot of the pool settings where we can see the control plugs and measurement sensors that are paired

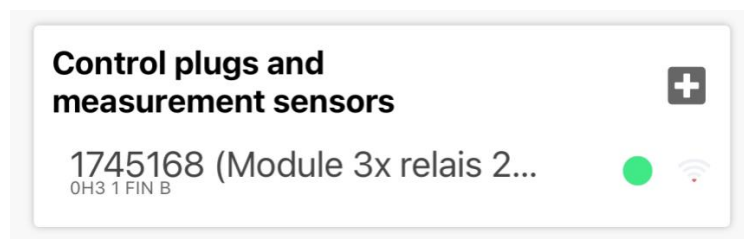

5 Add info@beniferro.eu as user to your pool, promote 2 times to the level of co-owner.

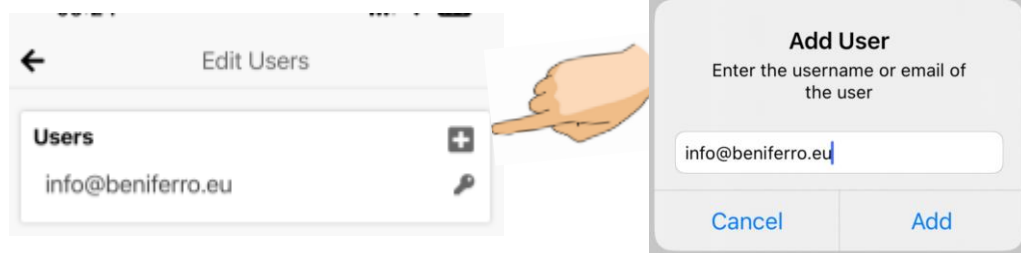

See section 3.1.1.2.1 below

Please send this information along with the problem description and the name of your pool to info@beniferro.eu.

3. Using the Wifipool app

3.1. Pool Settings

The Pool settings page is the page with which you will add new equipment (such as plugs and measurement boxes) , and define how your pool will be controlled. Via this page you can add additional users, edit the pool characteristics and verify the status of devices and automations.

There are 2ways to enter the Pool settings page :

From the main page click directly on your swimming pool name or on the 3 bars in the top left corner

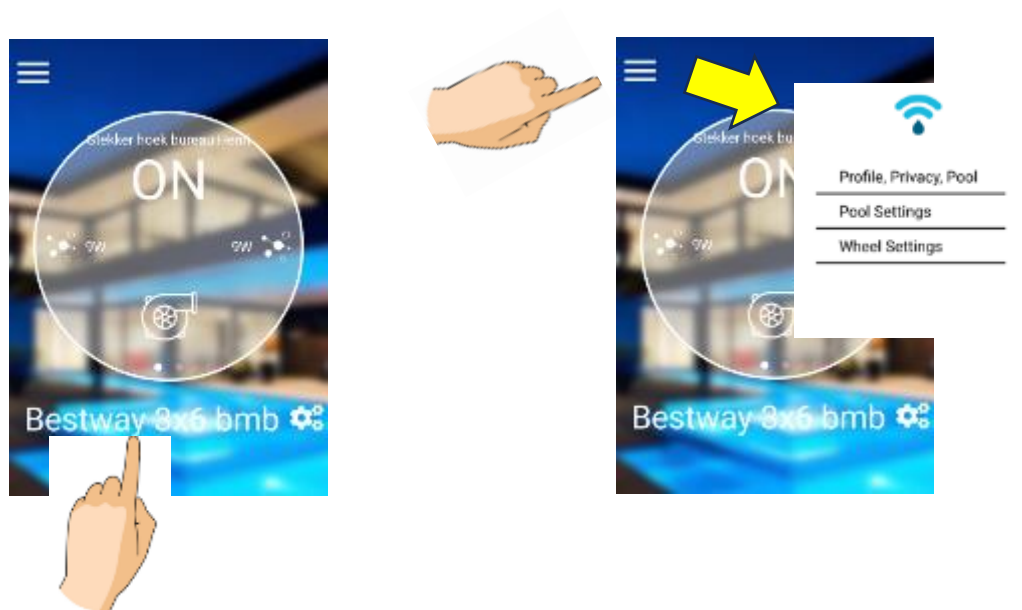

3.1.1. Pool

3.1.1.1. Pool Name

Give your swimming pool a name. In case you share your pool with other people (see “users”, it is important to choose a recognizable and original name. Type in your new pool name in the text field.

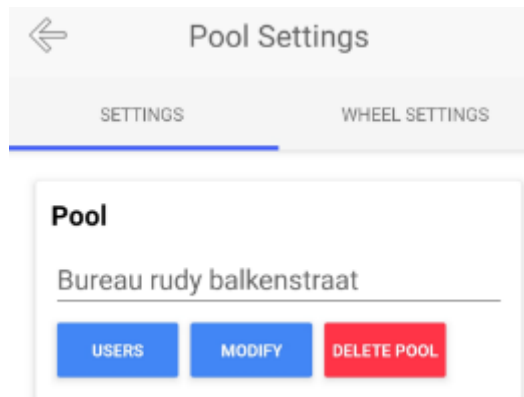

3.1.1.2. Users

3.1.1.2.1. Adding users

Via the "Users" tab, you can let other people watch or control your pool.

Go to the pool settings page and select users

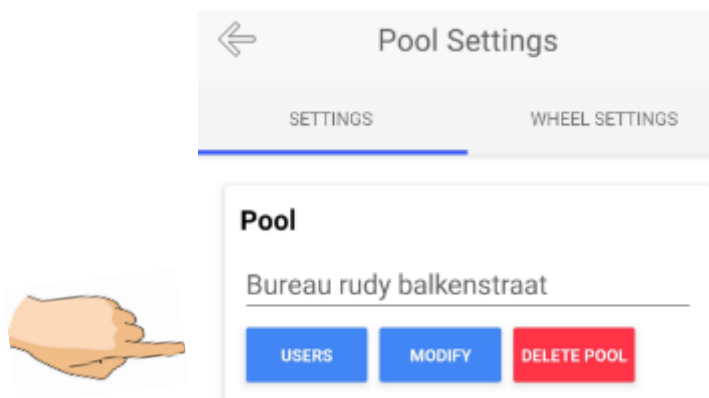

You can now add users to your pool. Click on the little plus symbol in the right top corner of the screen. The user is directly added to the pool. This user is "Read only" (3.1.1.2.1).

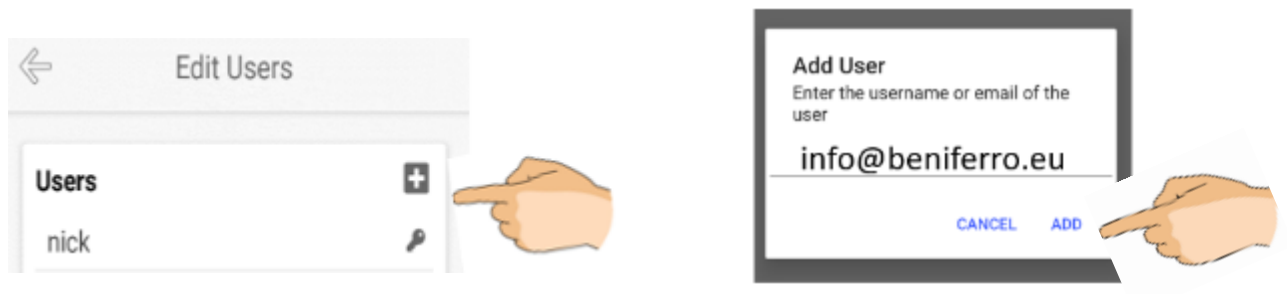



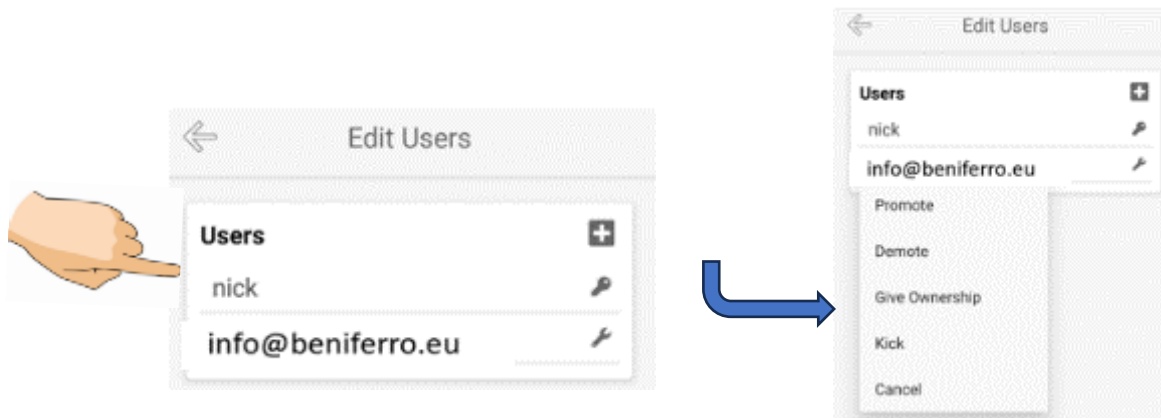

A popup window appears where you can type in the Wifipool username of the person you want to add.

3.1.1.2.1. Manage user rights

Click on the name of a user from the menu



There are 4 levels of restrictions you can add for each User

-  Owner : can control the swimming pool, add, promote, give ownership and kick out users
-  Co-owner : can control the swimming pool and add and promote users
-  Partner : can look at the swimming pool and receive notifications
-  Read only

Be aware that once you give up your own rights as an owner and this user now has the rights to kick you out as a user.

By promoting info@beniferro.eu to the level of co-owner, you can give the manufacturer access to your pool. This is a helpful feature in case help or troubleshooting is requested. In this case, make sure your pool has a recognizable and original name.

3.1.1.3. Modify Pool Characteristics

By pressing the modify button, you can edit and change your Pool characteristics. Filling in the Pool characteristics (such as Pool volume / Pool type...), will allow the app, to send you advice on your pool.

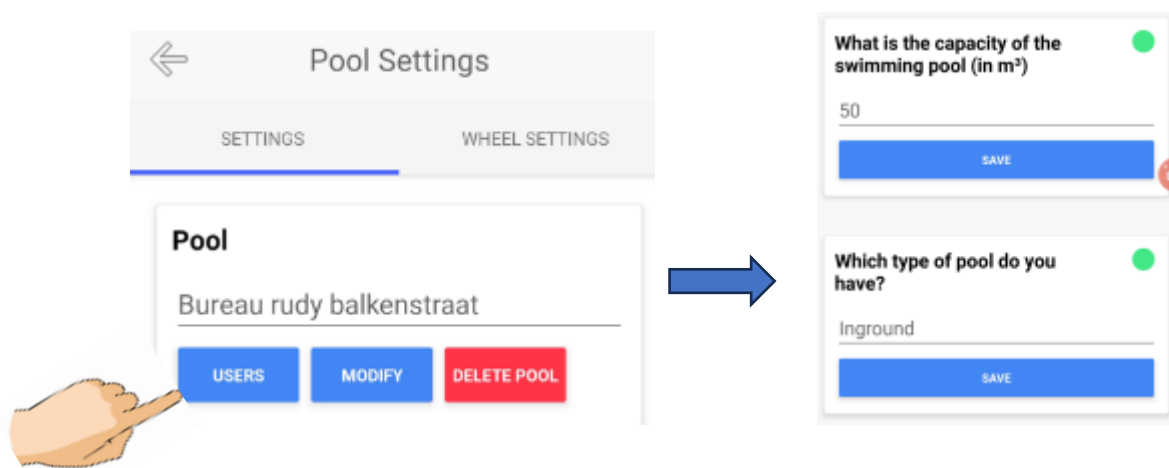

3.1.1.4. Delete Pool

Using this option will fully delete your pool, all pairing and automations. This action cannot be restored.

Please note: if you happened to delete your pool by accident. You have to manually reset your devices connected to the swimming pool.

3.1.2. Control plugs and measurements

The “Control plugs and measurements” section allows the user to have a quick overview of the devices in the swimming pool and their connection to the wifi network.

In addition, some direct controls such as calibration, manual control etc. are initiated via this section.

Before a device can be used, it needs to be paired with your home network and telephone. The pairing process of the control plugs and measurement devices has been described above.

After pairing, all devices are listed. The green circle indicates the device is connected to Wi-Fi, a red circle is not connected to the Wi-Fi. The number in front of each device is the serial number of the device.

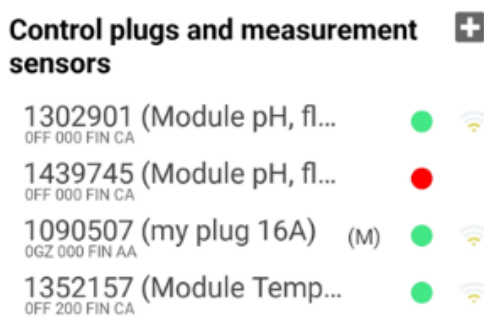

3.1.2.1. Unpair

The unpair / delete option will „delete“ a device, and make it available for other users / other swimming pools; Tick on the device name in “control plugs and measurement sensors”, followed by “unpair or delete”.

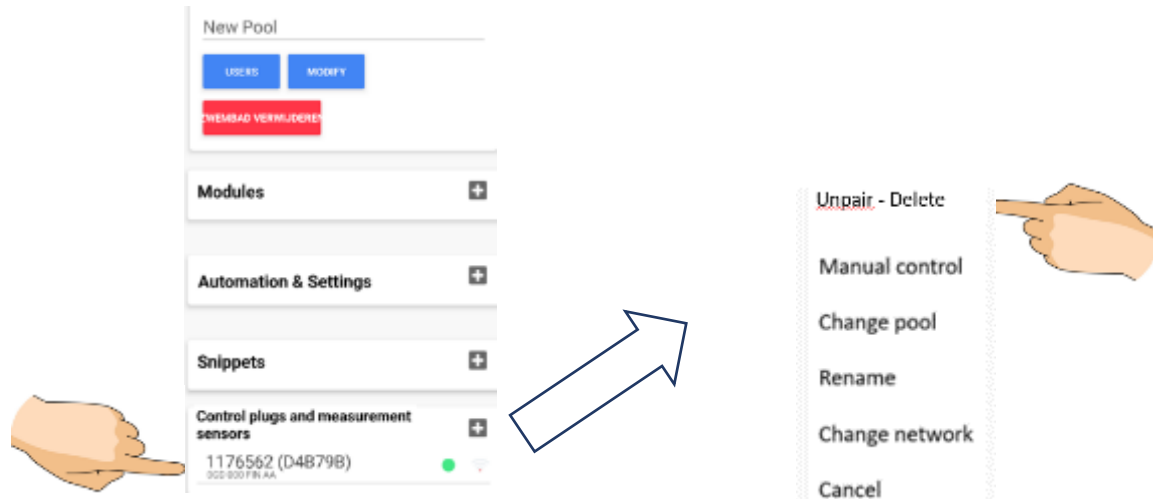

3.1.2.2. Manual control

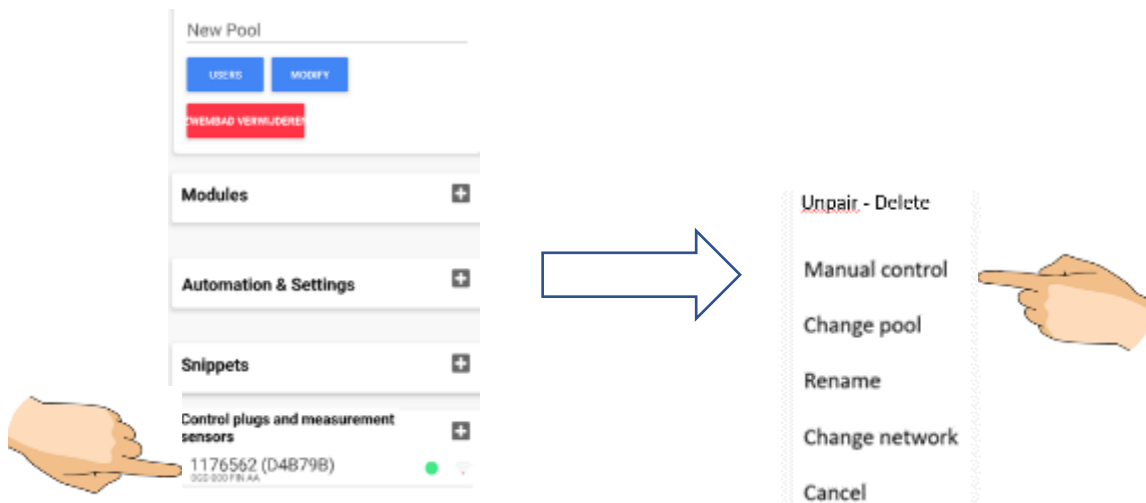

Click on manual control to switch from automatic to manual control. When using manual control, the owner, co-owner and partner of the Wifipool account, can start and stop manually the plug or smart switch. Although manual control can be helpful, it also contains risks. In case the pH peristaltic pump is started manually, it will keep on dosing liquid into the pool, regardless if this is needed or not.

Therefore, it is necessary to acknowledge that you have been informed of the risks associated with manual control, before you can access the control itself.

Once entered the manual control, it is possible to return to automatic via the green “switch to automatic button” . You can toggle the pump (or other device) on or off by tapping or swiping the grey toggle to the left or to the right.

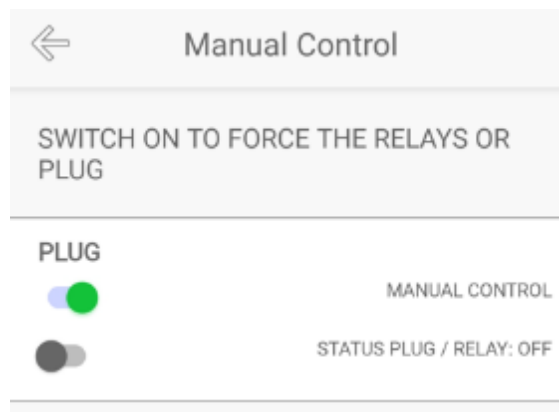

On the Pool setting screen, plugs and smart switches in manual mode, will be indicated with a “M” .Upon hitting the device name, a menu will unfold, by which it is possible to return to the automatic mode



3.1.2.3. Rename

Select Rename and enter in the new name for your plug. It is advisable to select a name which makes it clear which equipment this plug is controlling (eg Filter pump, pH peristaltic pump

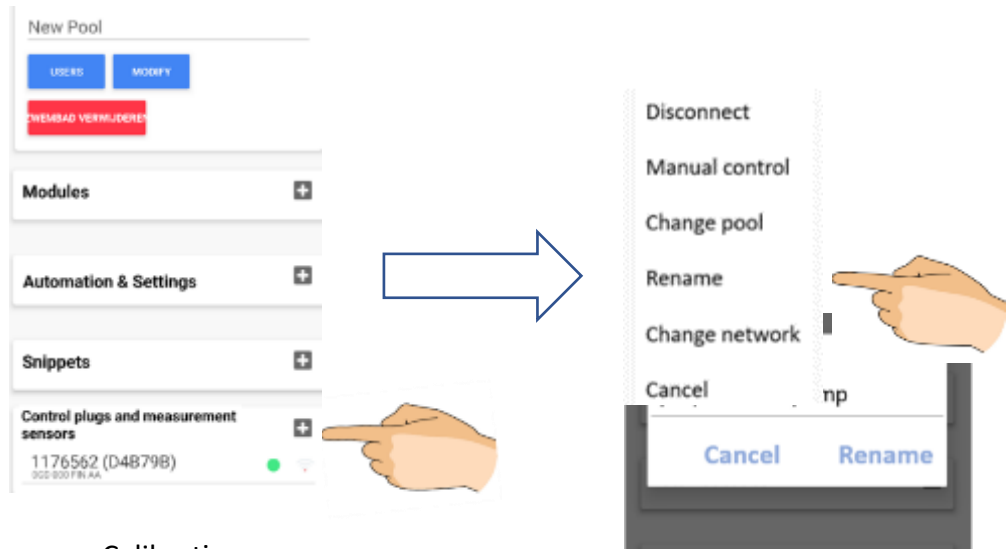

3.1.2.4. Calibration

To initiate the calibration process, tap on the pH or RX module line ("Module" in title) is between brackets. Once selected, the menu options will unfold, revealing a tab labeled "Calibration." Ensure you are prepared to remove the pH or RX probe from the installation and place it in the pH or RX calibration solution.

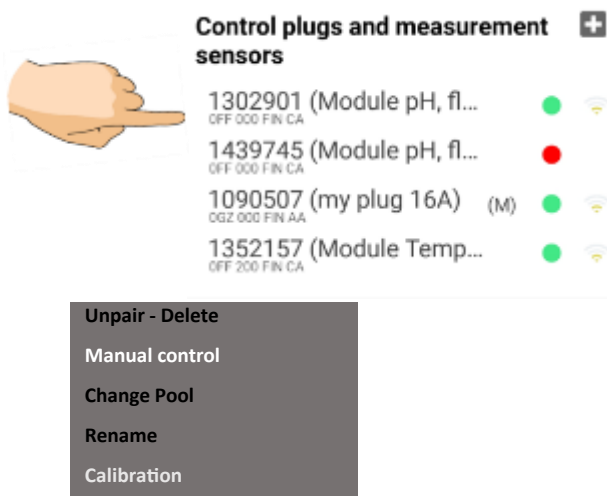

Follow the instructions on the screen to proceed with calibration.

3.1.2.5. Change Pool

3.2. Automation & Setting

With Gen 2, preprogrammed automations streamline the process by eliminating the need for manually adding automations check appendix 1 for extra info.

An automation makes the link between the measurements of a pool and a smart plug (or smart switch). Using the measurement results, we will start-stop a plug or smart switch. It is also possible to set up a timer and/or notifications in the automations

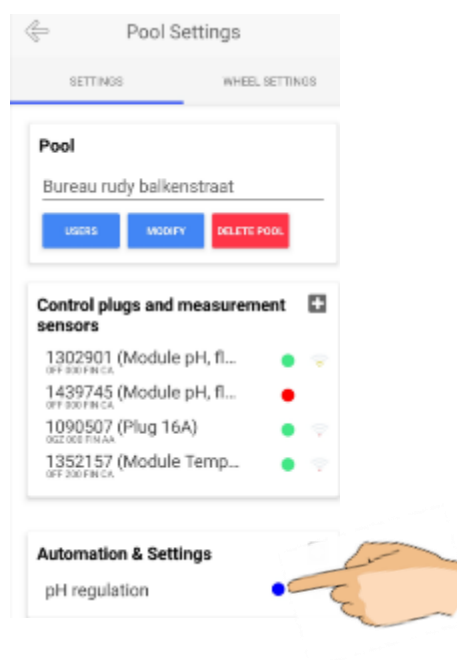

A blue circle behind the automation indicated the automation is not active because the target value has been reached, or because one of the conditions (e.g. a timer) stops the automation from running.

A green circle indicates the automation is running (e.g. pH pump is running).

The Wifipool automations have a feature called « duty cycle » .

A duty cycle of 30% / 60 seconds means that the power to the device being controlled will be on during 18 seconds each 60 seconds.

By enabling the duty cycle, it is possible to slow down the dosing of peristaltic pumps, enabling efficient water treatment in small volume pools and spas.

Attention:

The duty cycle parameter should not be adjusted by standard users. Altering this value can significantly disrupt the functionality and accuracy of your dosing device. Any modifications to these settings should only be performed by qualified personnel. Therefore, we strongly advise against making any changes to these parameters.

The Duty Cycle should never be used in combination with salt electrolysis or other pieces of equipment containing a control PCB.

The software is programmed with hysteresis. Hysteresis is a feature that helps prevent the device from switching on and off too frequently. Think of it like a buffer zone: it allows the device to wait for a small range before making adjustments, ensuring smoother and more stable operation. For example, in our system, the hysteresis for pH is set at 0.01, and for redox, it is set between at 10. This means the device will only make changes if the pH or redox levels move beyond these small ranges, preventing constant switching and ensuring accurate control.

3.2.1. Existing automation module

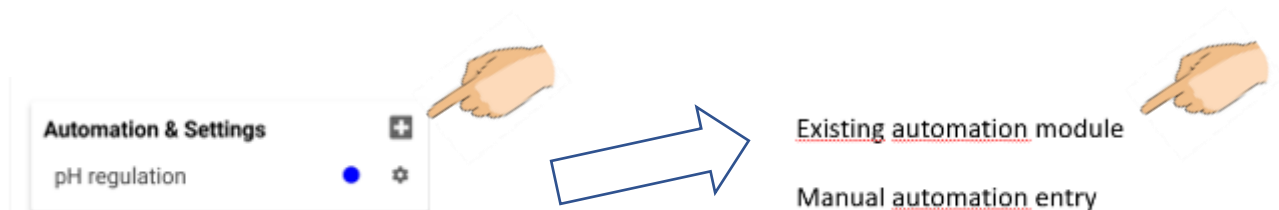

The existing automation module option allows the user to use a pre-defined automation module. The customer can choose between selecting a pre-defined automation or can scan a barcode from the manual joint to the product purchased.



Scanning the barcode or pressing the “Water treatment Liquid chlorine and acid for swimming pool, flow and level switch” link will have the same result : the full pre-defined automation will be installed on your swimming pool.

In this example, the regulation will be as follows :

pH and RX regulation (pH master)
 Daily Scheduler for water treatment between 9:30 and 17:30
 Notification sent to the phone if pH or RX is very high (>9) or low (<5.5) or no flow or low level.
 Safety stop if no flow or pH > 9 or RX >950 or level switch = low.

Appendix 1 gives an overview of the automation barcodes available.

The pre-defined automations contain all elements necessary to control correctly the equipment, including timers, notifications, safety stops if pool values deviate abnormally etc ...

We recommend to use a pre-defined automation and, if desired, adjust the values to your wishes. In the example below : press the « 7.6 » to modify the pH target value.

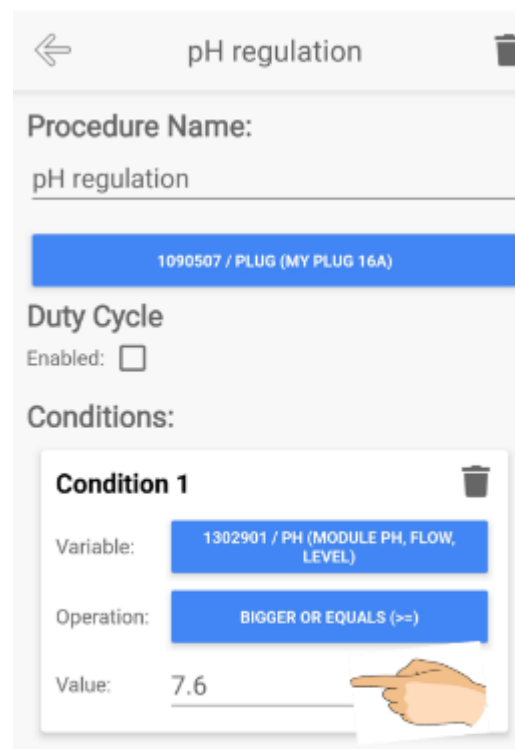

3.2.2. Manual automation entry

The automations can be entered manually as follows :

- Click on the **+** sign in the right corner, next to automations your pool settings tab which opens the “new procedure” page. Enter a name for you procedure

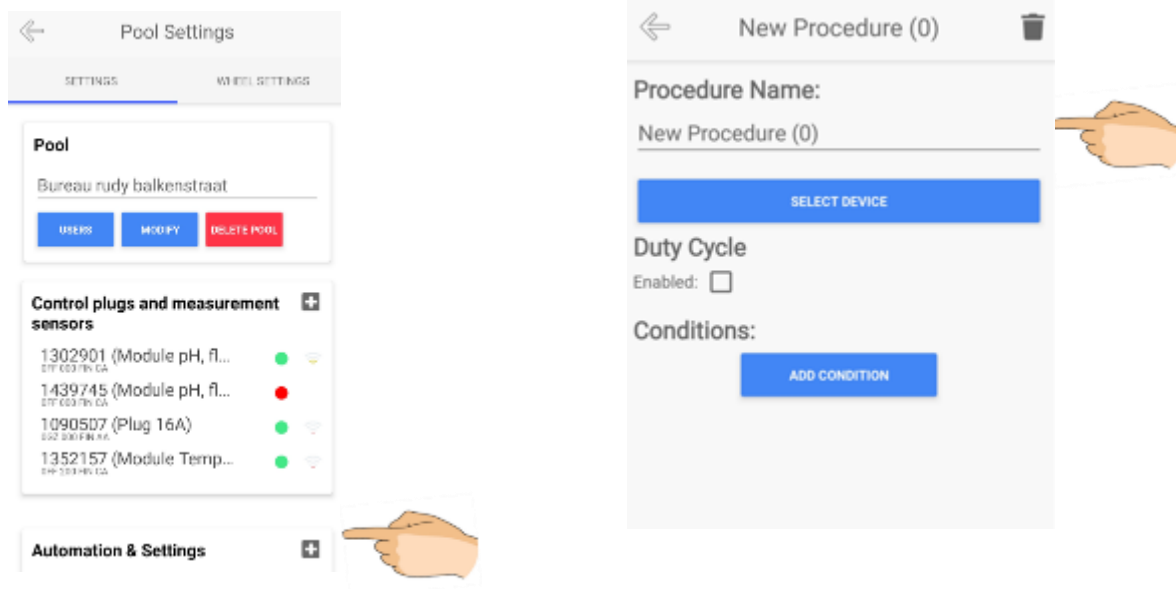

- Select the Wifipool device (plug , smart switch (or equipment containing a smart switch such as a peristaltic pump) you want to start and stop.

OR

- Select Push notifications to define de conditions under which you have to receive a notification.

In the example below, we create the procedure “pH control” by selecting our pH peristaltic pump as action device



- Define the condition

By pressing the “Add condition” button, we can select conditions at which the pH pump has to turn on. In our pH control example, we choose to start the pH pump (when the pH is larger or equal to (\geq)7.6 AND (by adding once again a condition) the flow switch detects flow.

In the example below, the pH pump will run only if $\text{pH} \geq 7.6$ AND the flow switch detects flow.

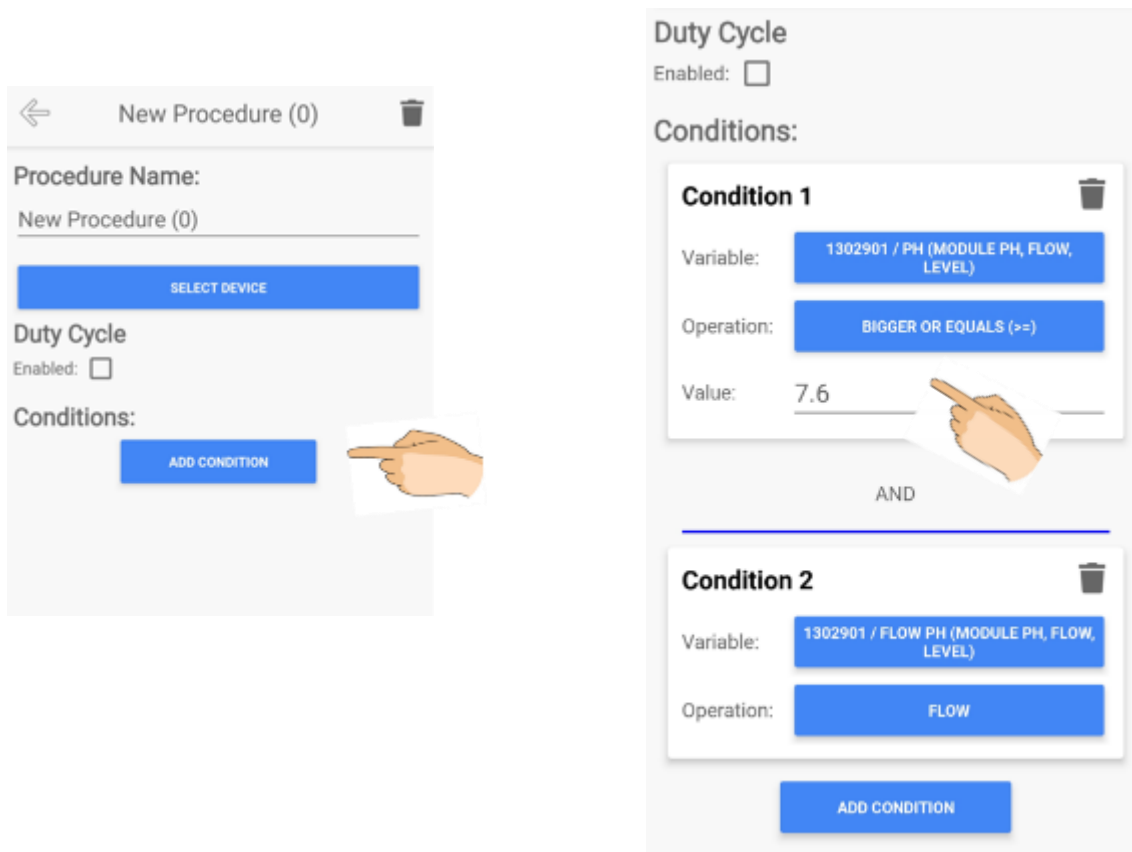

A unlimited number of conditions can be added

- Duty cycle:

With the duty cycle you are able to select the intensity for your device (output) to run on.
For example: Duty cycle % 30 Period (s) 60

This means that during the period of 60 seconds your device will run for 18sec in total (30% of the interval)

Click on enabled if you would like to use the duty cycle and in the values for your desired duty cycle

← pH regulation 🗑️

Procedure Name:
pH regulation

1090507 / PLUG (PH REGULATION PLUG 16A)

Duty Cycle
Enabled:

Duty Cycle (%): 30

Period (s): 60

In our example , the pH pump will run 30% of 60 seconds (= 18 secondes) per minute IF the pH > 7.6 AND flow is detected.

The duty cycle is typically used to reduce the dosing speed of peristaltic pumps.

Attention : never use the duty cycle with instruments which start up via a control PCB such as a salt electrolysis, frequency regulator, heat pump etcThe duty cycle will cause the instrument to switch on and off very frequently. This may cause electroic failure.

- Timer - scheduler

When selecting a condition, “Scheduler” is a option. When selecting the scheduler, a weekly schedule can be filled in.

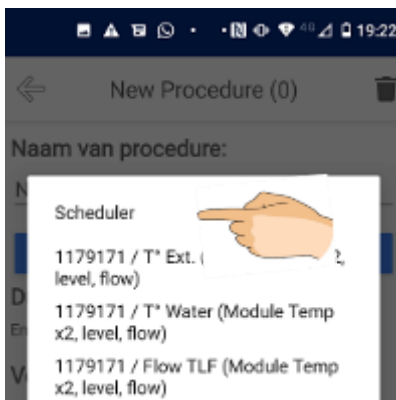

A weekly schedule will open, in which different time slots per day can be programmed

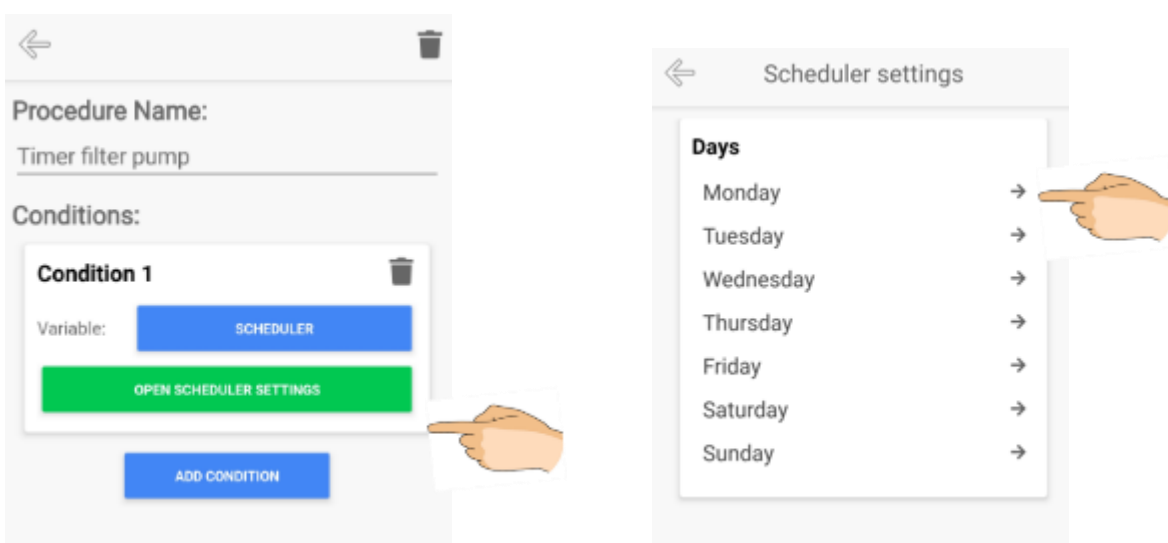

A alternative option for the scheduler, is to define a scheduler within the Snippets, and then selecting the Snippet as a condition. This has the advantage that the same timer can be used for several plugs / smart swtichtes.

3.3. Snippets

Snippets are “schedulers » which repeat themselves in several automations. As an example : the „Filter pump scheduler“, can be used for the filter pump as well as for the UV lamp plug.

Activate the Snippets by pressing the + sign, and complete and save the snippet just as described above in the “timer“ section

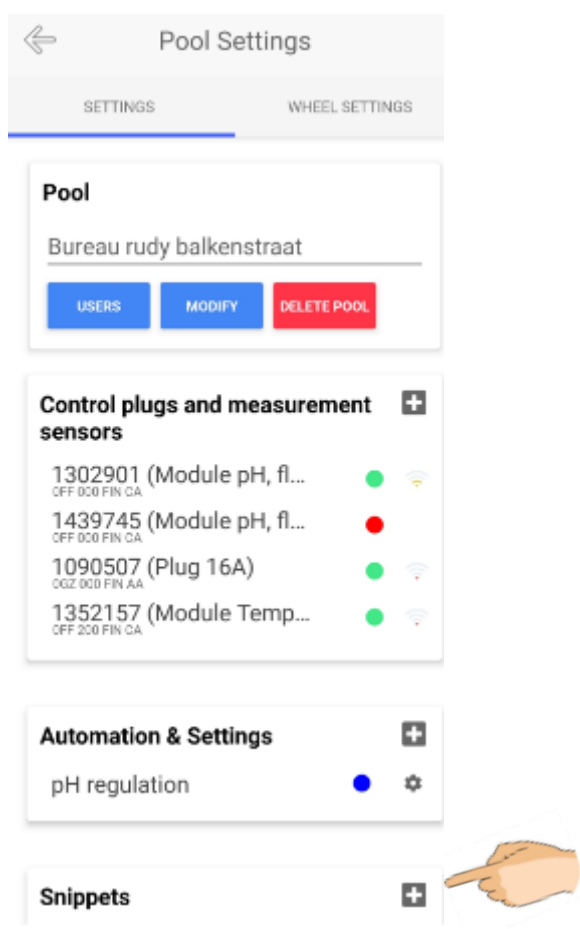

3.4. Notification scheduler

Adding a notification schedule

1. Scroll down to snippets. And press the plus icon. This will add a new snippet. Press the new snippet and change the “Procedure name” to something more appropriate (e.g. Notification scheduler). And press “Add condition”.

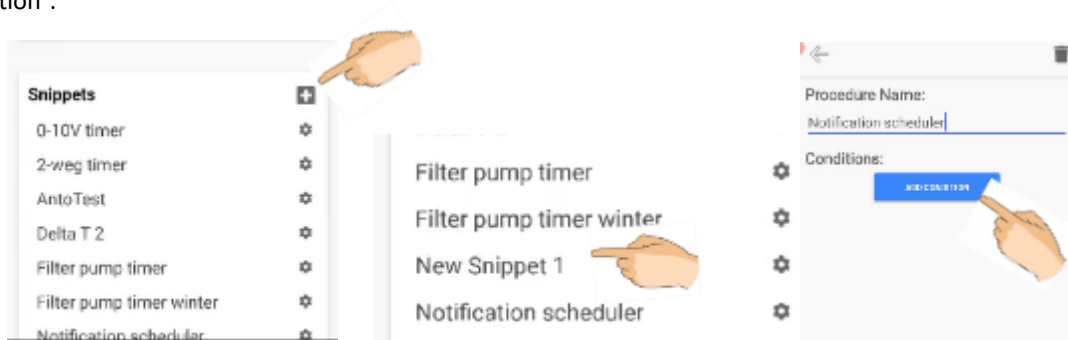

2. In the newly added condition just press “Select measurement”. All the way on top you’ll see an option with “Schedule” just select this.

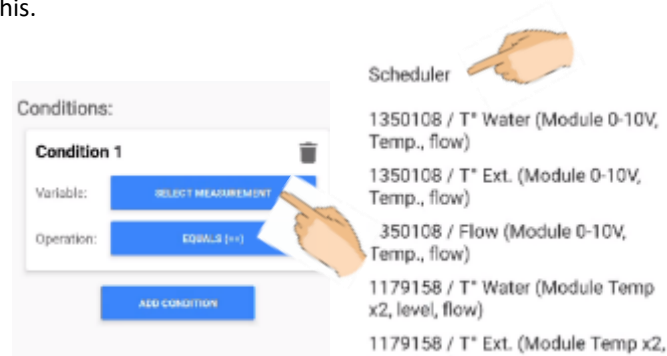

3. You can open the schedule settings now by pressing “Open schedule settings”. All days of the week will be displayed. Open for example Monday, and tab “add more” to add a new interval.

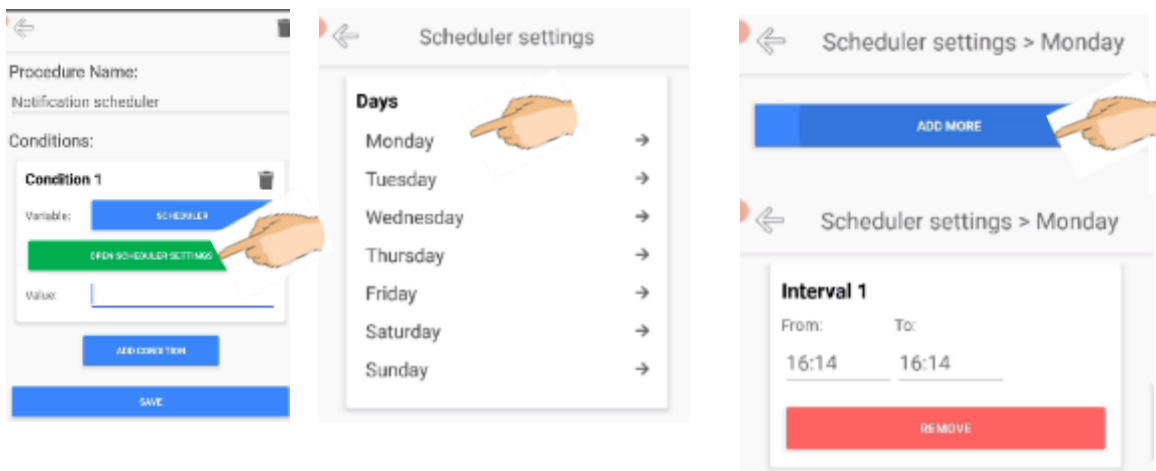

4. Modify the interval time “from” (when to start your operation) and “to” (when to stop your operation). E.g. 10:00 to 16:00. You have to manually change this for each day of the week. And press “OK”.

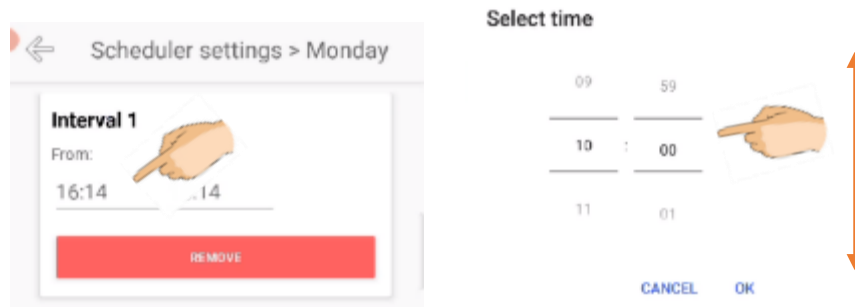

5. Once that's complete just navigate back to your Procedure settings and press save. After that you can go back to your pool settings and follow the instructions below to add an alarm notification.

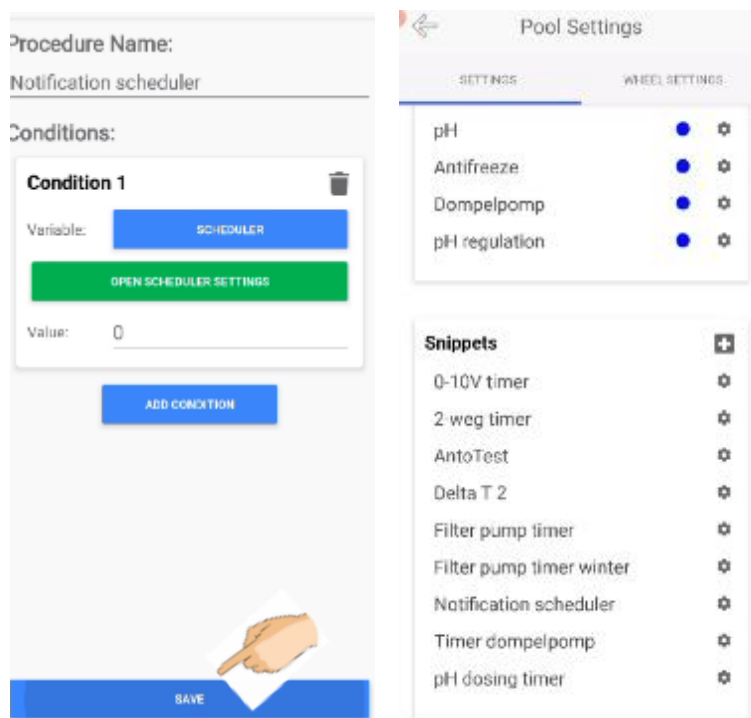

Adding alarm notification.

Make sure you also add an alarm notification in the manually entry itself.

6. In automations press the plus icon tab manual automation entry. Change the procedure name (e.g. pH > 9 alarm) and press “select device”.

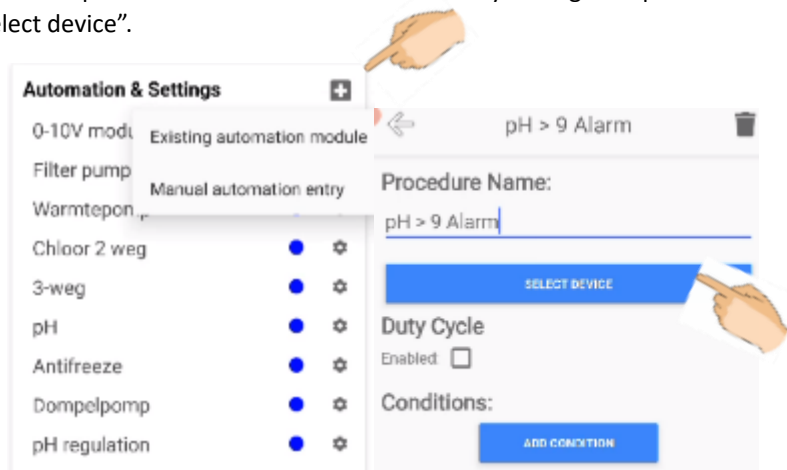

7. In select open “Alarm notification”. And change alarm message (e.g. pH > 9). Make sure to tab “add condition” and select, for example, your pH module.

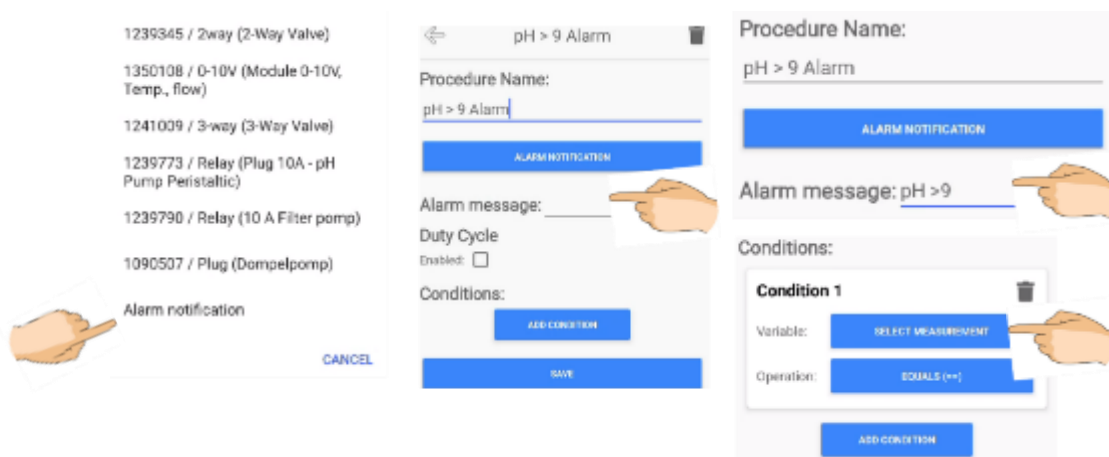

8. In here you can modify your operation and value.

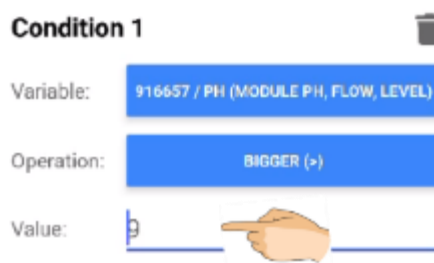

9. Finally press save.

3.5. Wheel Setting

Via the wheel setting page, you will be able to modify how the wheel on the main page looks like. You can choose icons, change the order, decide what you see and don't see in the wheel.

Via the wheel page, you can access the graphs pages.

As a special feature, you will be able to set the « fail safe » of your action devices.

You can access the wheel settings page via 2 routes :

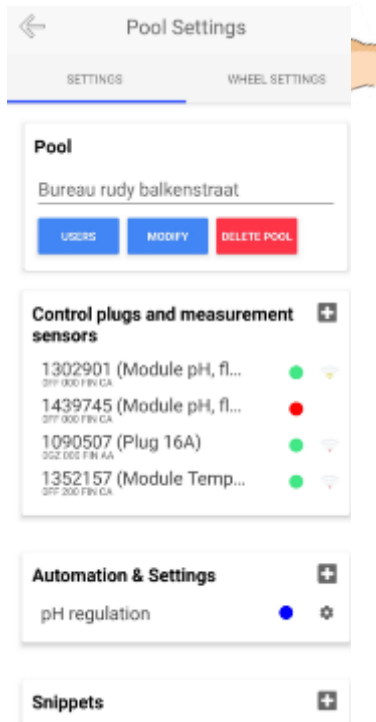

On Android phones

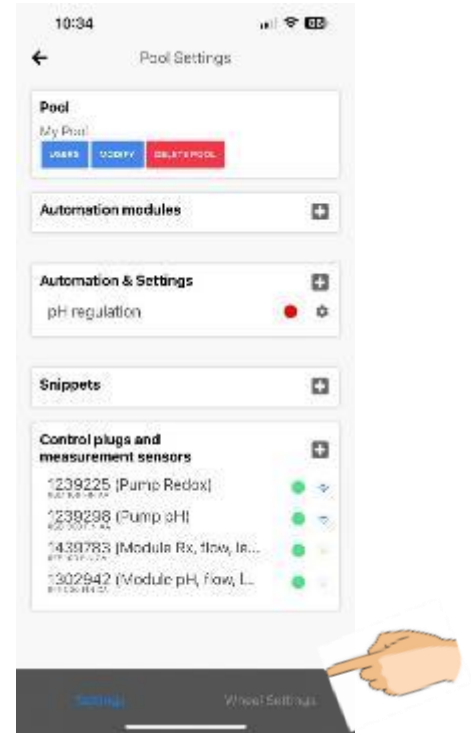

On iPhones

In the wheel, 3 variables are visible. By tapping the arrows, you can scroll through the pool variables displayed on the wheel. By tapping the graph symbol, you will see the graphical display of the last hour / 24H/3 days / week.

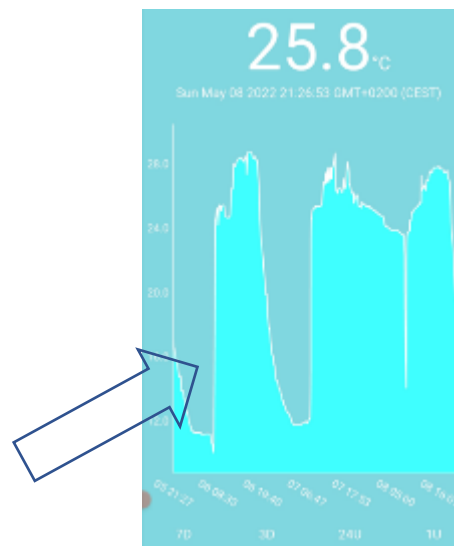
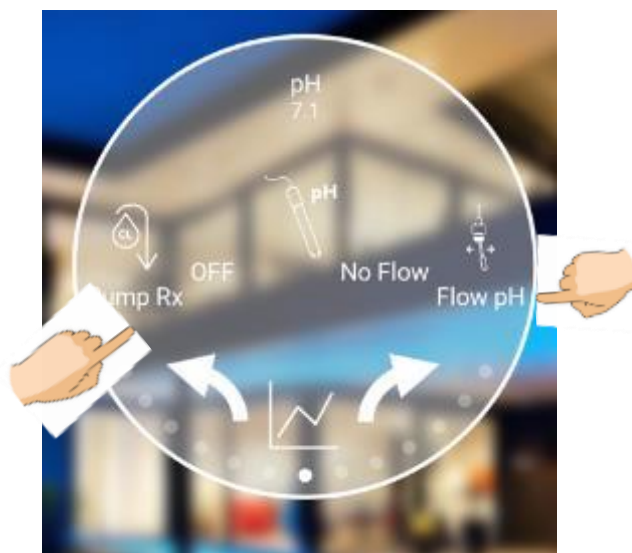

3.5.1. Wheel editing

Drag the items you want to make visible on your wheel dashboard from not visible to visible, by grabbing and dragging the 3 thin lines (sometimes you will need to hold your finger 3 seconds before dragging) at the right corner of your device. Make the reverse operation to make “invisible” items visible.

Moving items up or down within the visible zone, will change the order in which the devices are displayed on the wheel

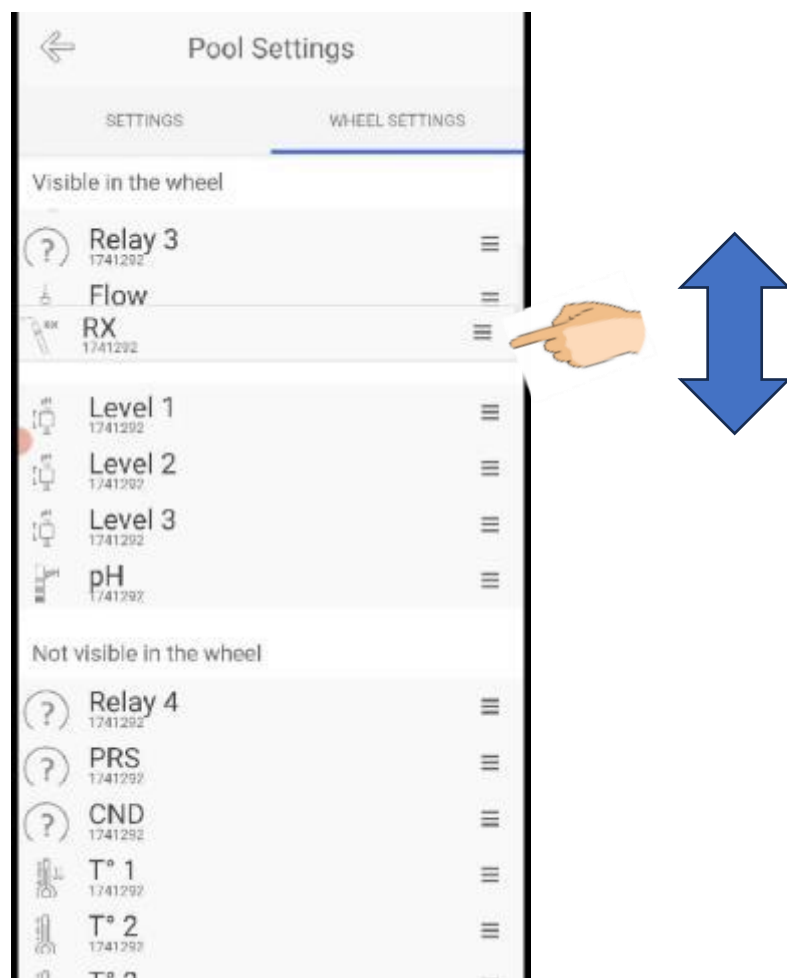

3.5.2. Icon selection

Tap on the device name in the “Wheel setting” page.

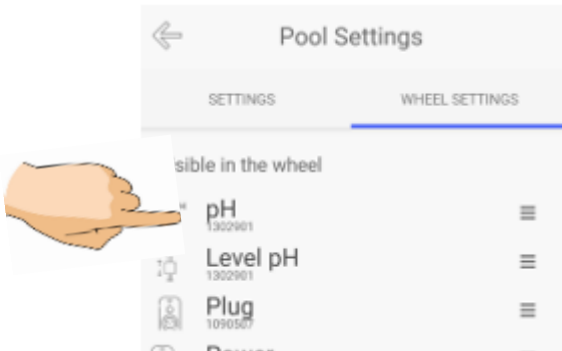

Select your favorite icon for your device. Go back by clicking on the top left corner arrow

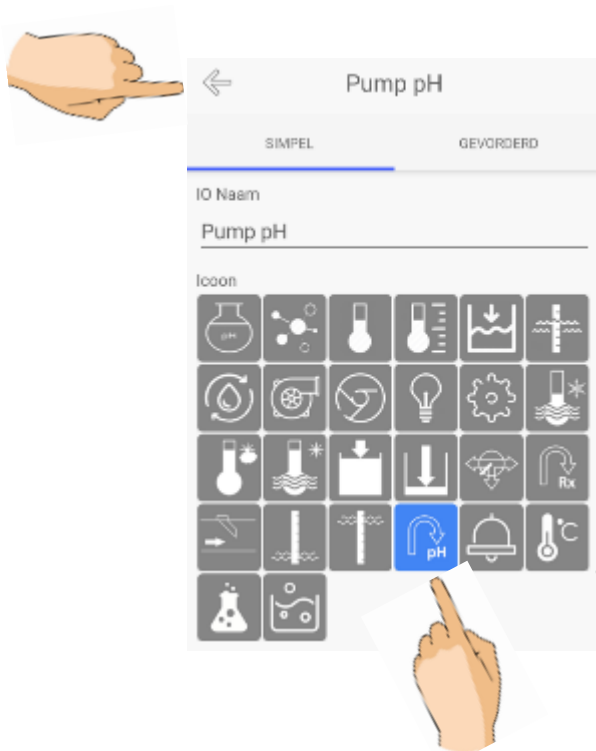

3.5.3. Failsafe mode

The Failsafe mode is used to define, what the device has to do in case wifi (or other) connection is lost : stop working or continue to work.

The failsafe mode can only be set for “action devices” such as plugs ,smart switches, pumps and automatic valves and not for measurement boxes.

To enter the failsafe menu, tap on the name of the device name once, followed by “advanced”.

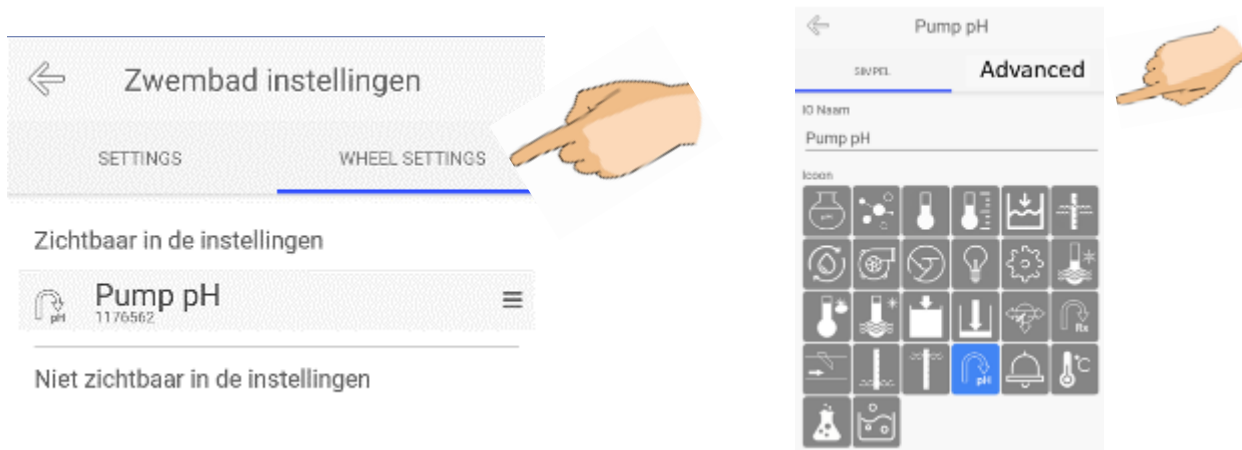

On the safety mode page, we can enter value 0 or 1.



At a failsafe setting of 0, the plug or smart switch will turn OFF during a system failure (e.g., loss of Wi-Fi). This setting is suitable for devices like a pH peristaltic pump. During a Wi-Fi loss, the pump needs to stop pumping.

At a failsafe setting of 1, the plug or smart switch will turn ON during a system failure (e.g., loss of Wi-Fi). This setting is appropriate for a winterizing filter pump, programmed to operate when outside temperatures drop below 2°C. If Wi-Fi is lost, the pump needs to continue running to prevent freezing.

Caution = be aware of the risk when switching failsafe on or off.

Example: set the pH dosing pump to failsafe 1, can cause pH- to be pumped nonstop to your swimming pool when internet connection is lost

The failsafe mode can only be set for “action devices” such as plugs ,smart switches, pumps and automatic valves and not for measurement boxes.

3.6. Action devices : Plugs and switches

Gen 2

In gen 2, there are no plugs or switches bur relays built right into the device itself. The Gen 2 connects straight to its power supply, as well as the pH pump and RX pump, making everything simple and straightforward.

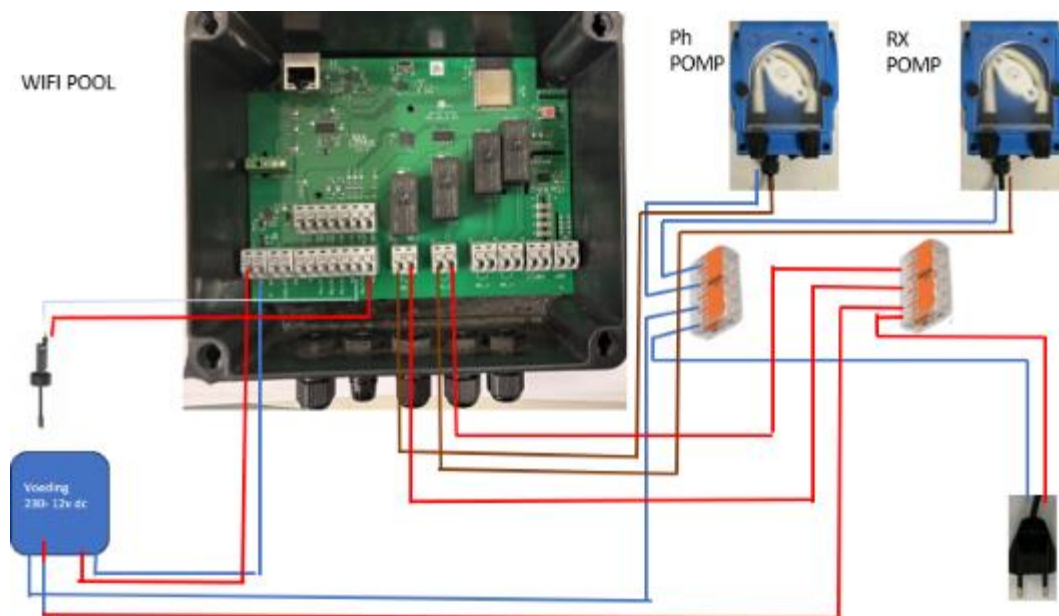

Gen 1:

Action devices, are devices with which you can start, stop, activate or deactivate a piece of equipment.

The Wifipool products are compatible with Shelly action devices, but only when the Wifipool software has been injected in the shelly devices

3.6.1. Plugs



Control plug 16A



Control plug 10A

The plugs operate on 230V

These plugs and switches will allow a pool equipment, such as a filter pump, UV lamp, peristaltic pump etc. to switch on or off. They are excellent for retrofitting existing equipment (such as a filter pump, peristaltic pump, lighting etc.) in the Wifipool app.

The plugs measure the power consumed.

3.6.2. Smart switches



Smart switch 16A



Smart switch 16A



Smart switch Plus 2 PM

Depending on the smart switch, they operate on 12, 24 and/or 230V.

These switches will allow pool equipment, such as a filter pump, UV lamp, peristaltic pump etc. to switch on or off. The Shelly smart switch 2 PM is used to switch a piece of equipment (e.g. an automatic valve) between position A and B. In some cases you will find these switches “hidden” in the Wifipool equipment.

Only the “red” smart switch; measures the consumed power.

The smart switches need to be connected to the pool equipment as follows :

Connection with on-off switch
For smart plug ZWPX0010

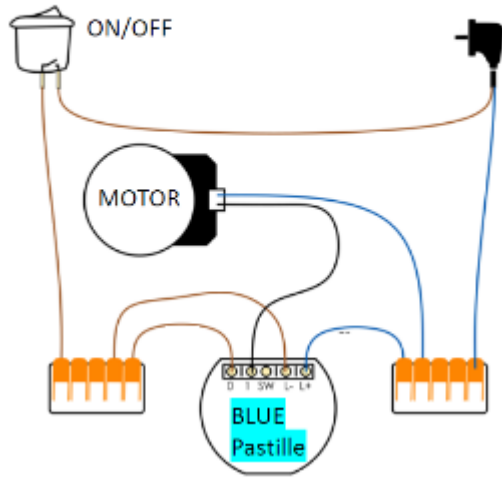

Connection without on-off switch
For smart plug ZWPX0010

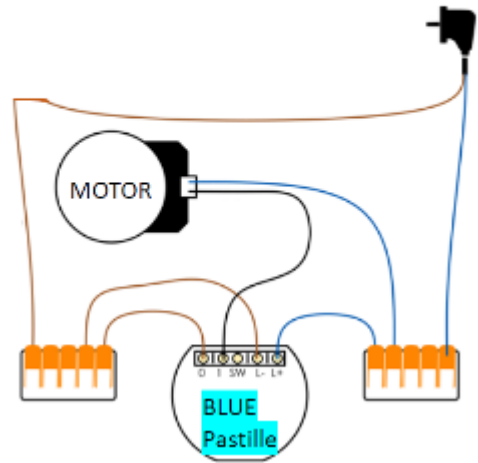

Connection with on-off switch
For smart plug ZWPX0020

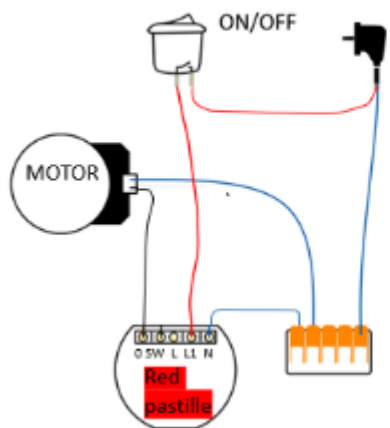

Connection without on-off switch
For smart plug ZWPX0020

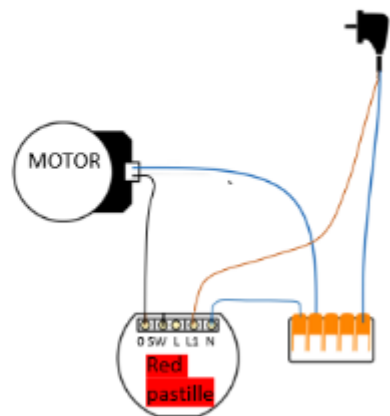

Equipment dependant
open/close connections

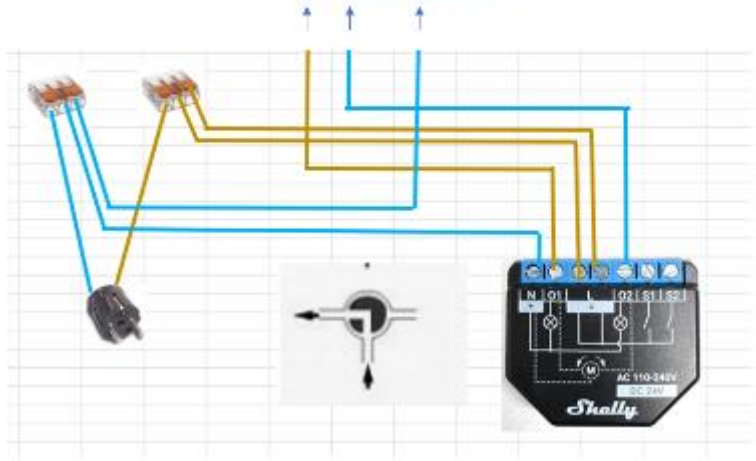

For the Shelly 2PM module,
the exact wiring depends on
the specific product.

3.7. Measurement devices

3.7.1. pH, RX and Temp

Our system contains 3 measurement boxes



pH, level, flow



Redox, level, flow



Temperature (x2), level, flow (TLF)

The units operate on a 5V USB plug, and consume less than 1 Amp.

The pH and RX probes have a regular and standard BNC connection

Level switch, flow switch and temperature probes have a male/female 3 or 2 pole water-tight Higo connection which are color coded so no mistake is possible.

These measurement boxes will allow you to measure various pool characteristics, which will be displayed on the mobile phone. Via the automation menu, it will be possible to steer the plugs and smart switches, depending on the measurements.

When adding a new measurement (flow or level switch) : disconnect the measurement box from the power, plug in the sensor, and connect to the power while the sensor is off position (no flow, low level)

For the temperature measurement box, it is necessary to plug in the measurement probes, before connecting the box to the power. If you see that the outside temperature and water temperature are "switched", then unplug the temp unit from the power, switch the temperature probes and plug the temp module into the power.

3.7.2. Combined measurement and control devices

3.7.2.1. 0-10V and 4-20mA

The 0-10V and 4-20mA modules contains both a “action” part and a “measurement part”

The modules can emit a constant voltage between 0 and 10V, or a constant current between 4 and 20mA. The modules can be used to control a external device.

The frequency regulator is controlled by applying a voltage to the regulator, where 0V = 0 rpm and 10V = 2950 rpm.



Both modules have one flow and two temperature measurement connections.

3.7.2.2. All-in Gen 2 – 2024

In gen 2 there are no more plugs and switches to worry about. Now, everything you need is built right into the device itself.



In a Gen 2 equipment , there are following measurements :
pH, RX, temperature (x3), level (x2), flow, pressure and conductivity (salt content).

There are 4 relays which can control 12-240V powered devices.

Additionally, Gen 2 introduces new connectivity options. Alongside Wi-Fi pairing, there's now Ethernet pairing available. While Wi-Fi is an option, it's important to note that the company prefers Ethernet connections. In the event of Wi-Fi issues, users may be subject to charges, so it's recommended to utilize Ethernet for optimal performance.

Not only is Gen 2 more connected, but it's also quicker to install. In previous generations, users had to scan each module separately during setup. However, with Gen 2, only one barcode needs to be scanned, and it's ready to go. This streamlined process minimizes installation time and hassle, getting users up and running faster than ever before.

Moreover, Gen 2 comes equipped with preprogrammed automations, further enhancing its user-friendly nature. These built-in automations simplify tasks and workflows, providing added convenience and efficiency for users. With Gen 2, automation is at your fingertips, ready to streamline operations and maximize productivity.

4 Problem Solving

4.1 Resetting your Wi-Fi equipment

After a “miscommunication” between cloud and device, it may be necessary to reset your device. To reset your smart plug you have to follow the Reset Procedure.

Gen 2:

To reset your Gen 2 WiFiPool device, please follow these detailed steps:

1. Open the Lid: Start by carefully opening the lid of your WiFiPool device. This will give you access to the internal components.
2. Locate the Red Button on the PCB: Once the lid is open, locate the red reset button on the printed circuit board (PCB). It is essential to identify this button correctly to proceed with the reset process.

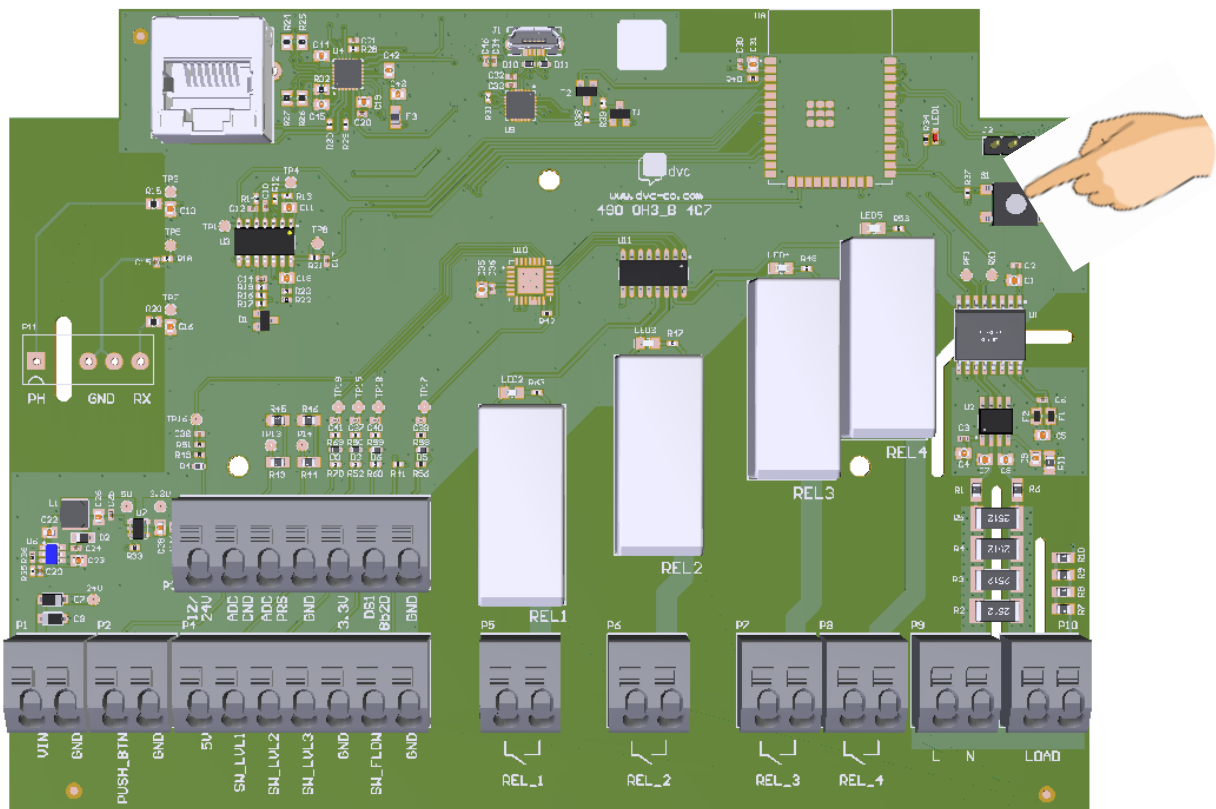

3. Hold the Reset Button: Press and hold the red reset button for exactly 40 seconds. Use a timer or a stopwatch to ensure that you hold the button for the full duration. Timing this step accurately is crucial for a successful reset.
4. Verify the Reset: After holding the reset button for 40 seconds, release it and observe the device. The reset process should now be complete.
5. By following these steps, your WiFiPool device should be successfully reset and ready for use.

Gen 1:

- Plug your smart plug in the outlet
- Plug out the USB for 10 sec
- Plug in-out the plug 7x

1. Plug your USB briefly in (1sec) and then pull out your USB for 2 Sec
2. Plug your USB briefly in (1sec) and then pull out your USB for 2 Sec
3. Plug your USB briefly in (1sec) and then pull out your USB for 2 Sec
4. Plug your USB briefly in (1sec) and then pull out your USB for 2 Sec
5. Plug your USB briefly in (1sec) and then pull out your USB for 2 Sec
6. Plug your USB briefly in (1sec) and then pull out your USB for 2 Sec
7. Plug your USB in and leave it in on the 7th time



Repeat 7 X



The same procedure applies also for the smart plug



Repeat 7 X



... procedure correctly than y... app and scan for devices : your phone will be searching for the plug.

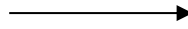
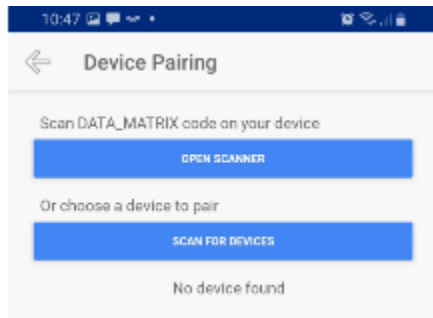

4.2 Notifications do not arrive consistently

On most devices, an app has background processes that allow it to do things like get notifications, which will remain active even when the app is closed.

Certain manufacturers (including OPPO & Xiaomi) have made their own versions of Android for their devices, so that notifications are not forwarded or only occasionally.

Fortunately, the settings that ensure that the app cannot forward notifications can be adjusted. The following article explains how you can make these adjustments for various devices (including of course OPPO) and thus hopefully receive the notifications as expected: <https://help.pushwoosh.com/hc/en-us/articles/360028478751-Android-device-cannot-receive-push-notifications-when-an-application-is-force-stopped-killed->

4.3 Pairing

Pairing problems have been addressed above

4.4 Contact troubleshooting

For troubleshooting, contact your supplier or contact info@beniferro.eu .

To make sure you can be helped efficiently, make sure info@beniferro.eu has become a user level co-owner of your pool (see section 3.1.1.2)

Appendices

Appendix 1: Preprogrammed Automations

In Gen 2, automations occur automatically after pairing your device. These are already set up by the system upon installation.

You can view the preprogrammed automations in "Automation & Settings". Most of these preprogrammed automations are based on conditions that work for most pools. Automations ensure that your modules are activated when certain conditions are met. For example, if your pH level is above 7.6, then your pH pump will start, or when there's flow or no flow, high or low redox levels, etc.

You can manually modify these automations or add your own. To modify the automations, tap on the automation title, and in the menu, you can adjust the conditions to your preferences. Only modify these settings if you understand what you're doing.

To create new automations, simply tap the plus icon and follow similar steps to modification as described in the previous paragraph.

For Gen 1 devices, preprogrammed automations exist but these need to be scanned in via a barcode. See the quick start manual of the device purchased.

Appendix 2 : Pairing instruction sheet example

Pairing and automation Wifipool water treatment

Thank you for choosing our Wifi water treatment. For an easy and quick start, we recommend the following:

1 Install the wifipool app. Instructions for installing the app can be found in the attached Wifipool App Quick Start Guide and Simple Equipment.

2 Pair the device with your phone

It's best to do this indoors in an area with a good Wi-Fi network connection (the same network you'll use for your pool) and a modem with a network cable connection (ethernet cable)

3 Connect the Wifipool control box to your modem via a network cable (ethernet cable) and start pairing. If you want to pair over a Wi-Fi connection (not recommended), refer to the Wifipool App Quick Start Guide and Simple Equipment. Please note: Beniferro does not provide free support for pairing via Wi-Fi, if you have a device with a network cable connection

3.1: Go to the "Pool Settings" app page,
tap on the plus icon next to
"Sockets & Measurement Sensors".

3.2: Select "Scan" and scan this
barcode:



3.3: Select the Wi-Fi network you want to use for your pool equipment

Once pairing is complete, you can continue with or without a network cable. Without a network cable, a good connection to your Wi-Fi network is required.

4 During pairing, automation was also loaded.

5 Once you've calibrated the pH and RX sensors, you're ready to use your device.

Appendix 3a : Gen 2 technical specifications

ETHERNET CONNECTION	Desired for pairing Possible for daily operation
STABLE WIFI	Required if ethernet cable is not available - standard extender or powerline compatible
WIFI CONNECTION PROTOCOL	802.11b, 802.11g and 802.11n
WI-FI RADIO FREQUENCY	2412 - 2484 MHz
WI-FI RADIO SIGNAL POWER	<1mW
WIFI DISTANCE OUTDOORS	up to 50 m outdoors and up to 30 m indoors (depending on the building materials)

PCB WITH ETHERNET CONNECTION – GEN 2	pH, RX measurement Extendible with Temperature measurement (x3), flow switch, level switch(x3), pressure measurement, conductivity measurement 4 ON-OFF relays 12-240V
TEMPERATURE SPECIFICATION	-20°C to + 70°C
CONFIGURATION	Via mobile phone (preconfigured)
AVAILABLE LANGUAGES	NL, EN, FR, DE, IT, ES
RELAY CONTROL	12-240V
POWER SUPPLY	12-240V(relai) 12 or 24V (PCB power)

Appendix 3 b : Gen 1 technical specifications

STABLE WIFI	Required - standard extender or powerline compatible
WIFI CONNECTION PROTOCOL	802.11b, 802.11g and 802.11n
WI-FI RADIO FREQUENCY	2412 - 2484 MHz

WI-FI RADIO SIGNAL POWER	<1mW
WIFI DISTANCE OUTDOORS	up to 50 m outdoors and up to 30 m indoors (depending on the building materials)

TEMPERATURE SPECIFICATION	-20°C to + 70°C
CONFIGURATION	Via mobile phone (preconfigured)
AVAILABLE LANGUAGES	NL, EN, FR, DE, IT, ES

ETHERNET CONNECTION	Desired for pairing Possible for daily operation
STABLE WIFI	Required if ethernet cable is not available - standard extender or powerline compatible
WIFI CONNECTION PROTOCOL	802.11b, 802.11g and 802.11n
WI-FI RADIO FREQUENCY	2412 - 2484 MHz
WI-FI RADIO SIGNAL POWER	<1mW
WIFI DISTANCE OUTDOORS	up to 50 m outdoors and up to 30 m indoors (depending on the building materials)

PCB WITH ETHERNET CONNECTION – GEN 2	pH, RX measurement Extendible with Temperature measurement (x3), flow switch, level switch(x3), pressure measurement, conductivity measurement 4 ON-OFF relays 12-240V
TEMPERATURE SPECIFICATION	-20°C to + 70°C
CONFIGURATION	Via mobile phone (preconfigured)
AVAILABLE LANGUAGES	NL, EN, FR, DE, IT, ES
RELAY CONTROL	12-240V
POWER SUPPLY	12-240V(relai)

12 or 24V (PCB power)



BENIFERRO.eu
plug & play products

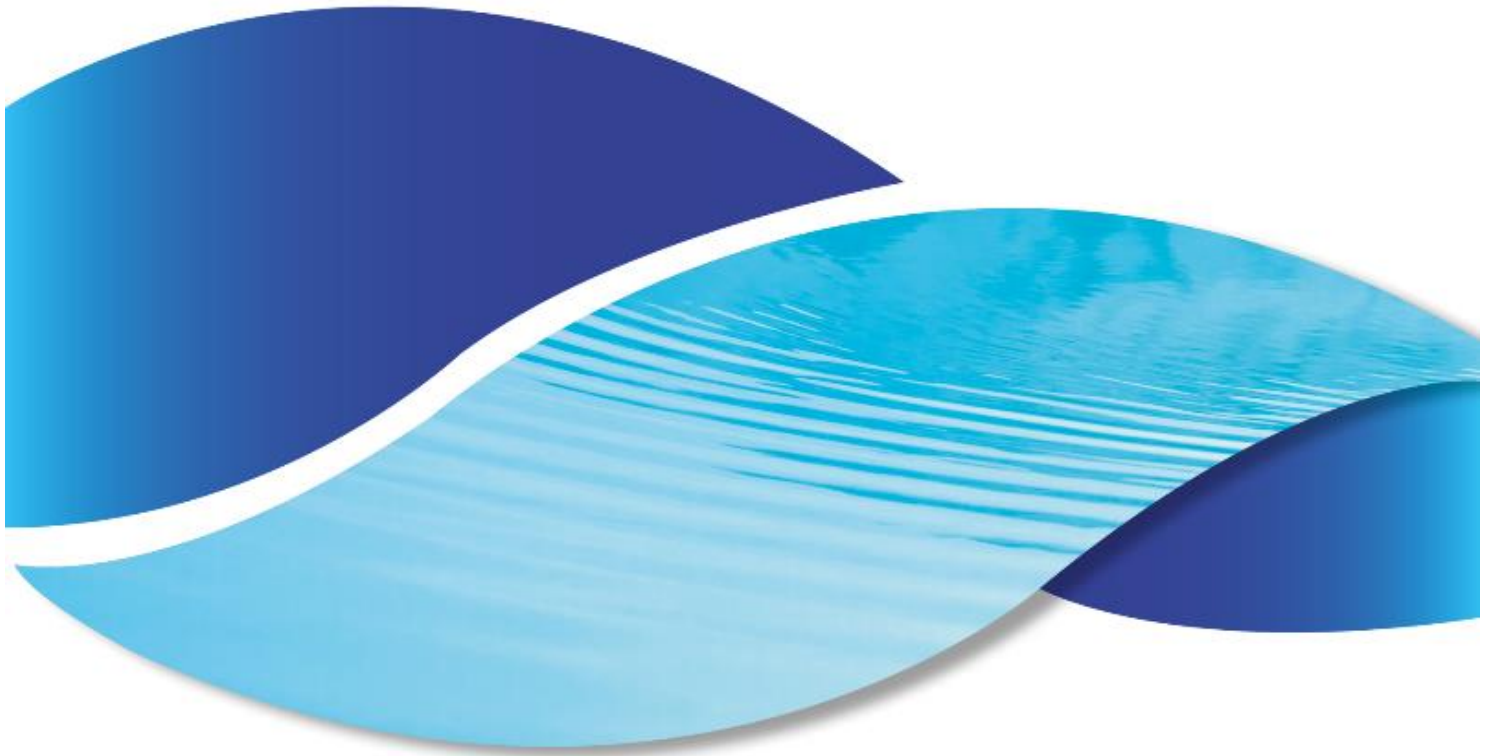

Wifipool App and Simple Devices – full manual

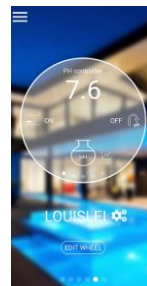

Contents

Introduction

1. The Wifipool app.....
 - 1.1. Introduction
 - 1.2. Installation of the app
 - 1.3. Changing your password, profile and privacy settings
 - 1.4. 1.4 Log out
- 2 Pairing.....
 - 2.1 What is pairing.....
 - 2.2 Problems with pairing.....
 - 2.3 Before pairing.....
 - 2.4 Pairing via ethernet connection.....
 - 2.5 Pairing via website.....
 - 2.6 Pairing via smartphone for IOS.....
 - 2.7 Pairing via smartphone of for Android.....
 - 2.8 Pairing trouble shooting.....
- 3 Using the Wifipool app.....
 - 3.1 Pool Settings
 - 3.1.1 Pool
 - 3.1.2 Control plugs and measurements
 - 3.1.3 Unpair
 - 3.1.4 Rename
 - 3.1.5 Calibration
 - 3.2 Automation & Setting
 - 3.2.1 Existing automation module
 - 3.2.2 Manual automation entry
 - 3.3 Snippets
 - 3.4 Wheel settings
 - 3.4.1 Wheel editing
 - 3.4.2 Icon selection
 - 3.4.3 Fail safe
 - 3.5 Action devices : Plugs and switches
 - 3.5.1 Plugs
 - 3.5.2 Switches
 - 3.6 Measurement devices
 - 3.6.1 pH
 - 3.6.2 RX
 - 3.6.3 Temp
 - 3.6.4 Control devices
 - 3.6.5 0-10V

3.6.6 Combined measurement and action devices

3.6.6.1 0-10V

3.6.6.2 All-in Gen 2 – 2024

4 Problem Solving

5 Appendices

5.1 Appendix 1 : automation barcodes

5.2 Appendix 2 : automation details

5.3 Technical specifications

Introduction:

The "Wifipool" app can be used to monitor and control your pool using the Wifipool Connect Pro Measurement and Control Box, smart plugs, and various sensors such as pH, Redox, and Temperature, along with associated accessories such as pH probes and temperature sensors.

To install and use the measurement and control box, you need to follow a series of steps:

- 1 Installing the Wifipool App
- 2 Connecting the Measurement and Control Box to the Wi-Fi Network and Phone
- 3 pH and RX calibration (if applicable) & automation



After completing these three steps, your device will be operational.

This manual describes the installation and use of the Wifipool app (step 1) and explains basic hardware functions (step 2)

The detailed specific operation of Wifipool filter pumps, water treatment modules, calibration and heating equipment are explained in the device manuals.

With Wifipool, it is possible to truly use one app for the control of your swimming pool.

We hope the product will contribute to a perfect pool control experience and great swimming pool pleasure

The Wifipool Team

1. The Wifipool app.

1.1.Introduction

The "Wifipool" app can be used to control your pool using the Wi-Fi pool measuring devices for pH and Redox, in combination with the Wi-Fi pool control devices such as smart plugs / smart switches, peristaltic pumps, and salt electrolysis.

The main page of the app features a wheel interface, displaying measurement values such as temperature, pH, etc. Swiping left or right on the wheel enables users to switch between multiple pools or create additional ones. **1** Tapping in the middle of the wheel or on the arrows allows users to toggle between different parameters of the selected pool, such as pH value, temperature, etc. **2** Tapping on the pool name redirects users to the pool's settings menu. **3** Selecting 'Edit Wheel' permits users to modify the content and order of the values displayed in the wheel.

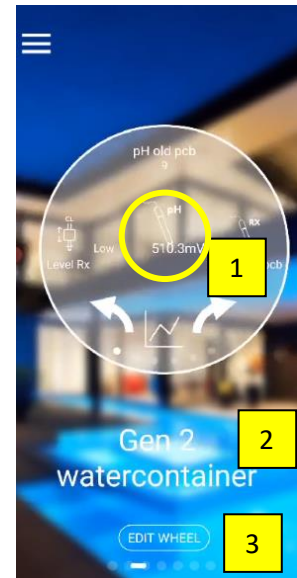

On the initial screen, **1** users can observe the status of your current value, whether it is on or off. Additionally, **2** there is a button for accessing statistics. Tapping the statistics button reveals how the current values are changing over time. **3** Two arrows, pointing left and right, facilitate navigation through the various pages. These pages include sections for pH, Rx, pH flow, and Rx flow.

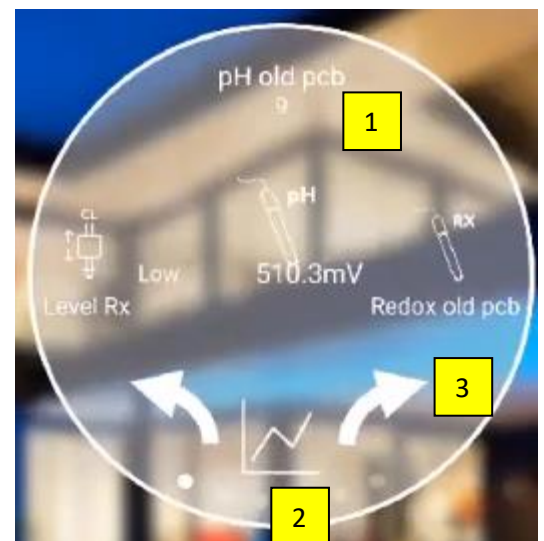

In addition to the Wifipool app, you need measuring boxes with accessories (probes, sensors etc.) to measure and display the pH, Redox, temperature etc. and smart plugs or other Wi-Fi pool control devices to turn your equipment on or off.



Before being able to use the app, you will need to install it. Then, you'll need to pair the Wifipool devices with your home Wi-Fi network and your phone. Finally, you will need to install the automations.

There are two versions of the Wifipool device: Gen 1 and, as of 2024, Gen 2. Gen 2 combines measuring and control devices on one PCB. Gen 1 operates via Wifi,, Gen 2 devices operate via Wifi and ethernet.





To connect the device, you first need to pair it to your phone and home network. Pairing via a ethernet cable is significantly more rapid and easier than pairing over Wifi.



1.2. Installation of the Wifipool application

1.2.1 Download the app

Android

1.  Go to the Google Play Store on your mobile device.
2.  Search for Wifipool
3. Click Download
4. Open the app and tab on the “Create one!” link. This will enable you to create an account. If you already have an account, you are not required to do so again. Continue following the instructions.

IOS (Apple)

1.  Go to the App Store on your mobile device.
2.  Search for Wifipool
3. Click Get
3. Open the app and tab on the “Create one!” link. This will enable you to create an account. If you already have an account, you are not required to do so again. Continue following the instructions.

1.2.2 Creating Wifipool Account

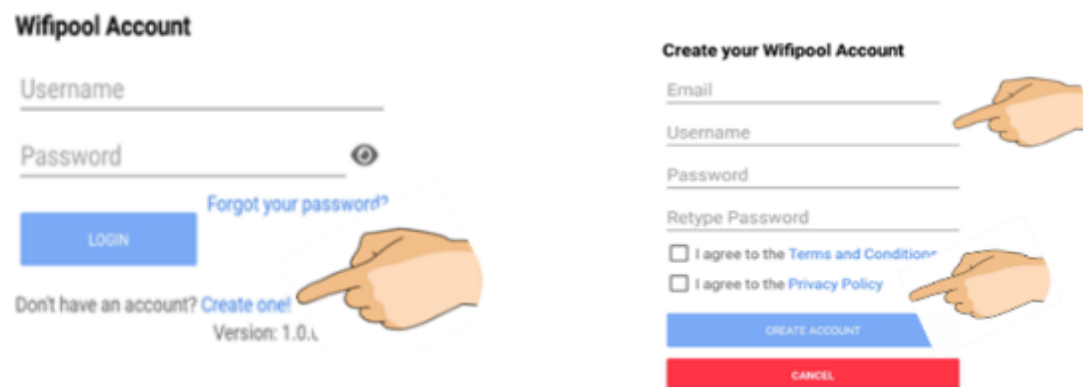

Wifipool Account

Username _____

Password _____ 

[Forgot your password?](#)

LOGIN

Don't have an account? [Create one!](#)

Version: 1.0.1

Create your Wifipool Account

Email _____

Username _____

Password _____

Retype Password _____

I agree to the [Terms and Condition](#)

I agree to the [Privacy Policy](#)

CREATE ACCOUNT

CANCEL

4. Enter your personal details and consent to the terms and conditions as well as the Privacy Policy to create a Wifipool account.
5. Press create account. The app will then send a verification email to your email address.
6. Proceed to your personal email account to confirm your email address. Check your 'spam' folder, as the email may end up there. If you haven't received an email, there might be a typing error in the email address or password. Consider trying to create the account again

1.2.3 Checking Wifipool version

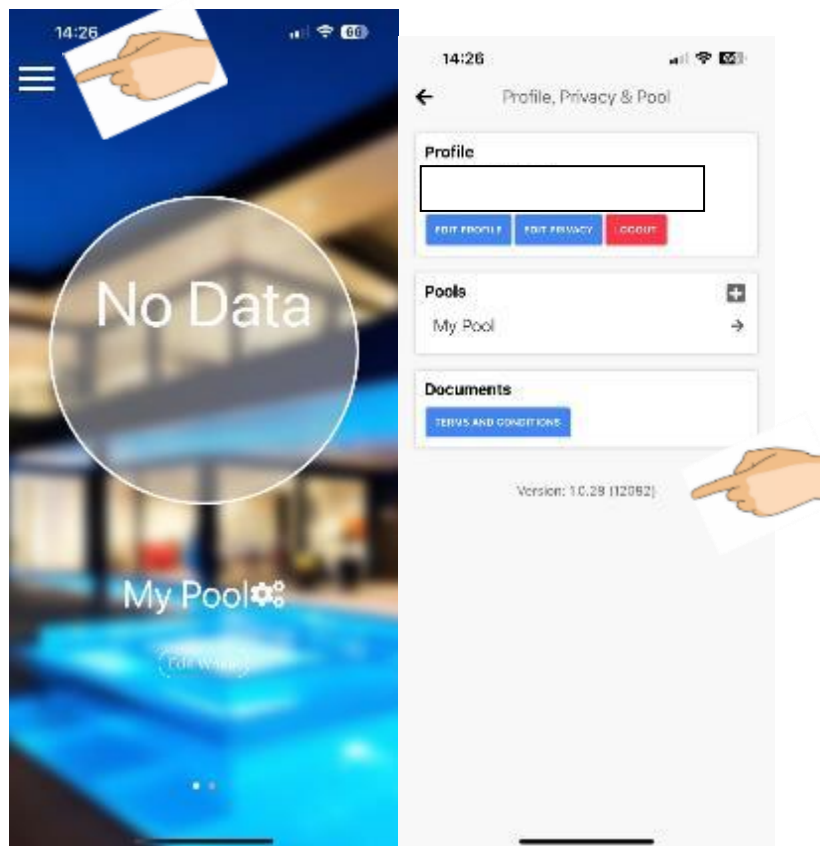

1. Always ensure you have the latest version of the app.
2. To do so, press \equiv in the top right corner of your screen.
3. This action will open the Profile, Privacy & Pool settings.
4. At the bottom of this screen, you will find the current version of the app.

Please note: The version displayed in the photo may not be the latest version of the app. Do not be alarmed if your version happens to be newer.

1.3.Changing your password, profile and privacy settings

Edit Profile and password

1. Click on the top left corner to go to the open the navigation bar and tab "Edit profile, privacy, logout".

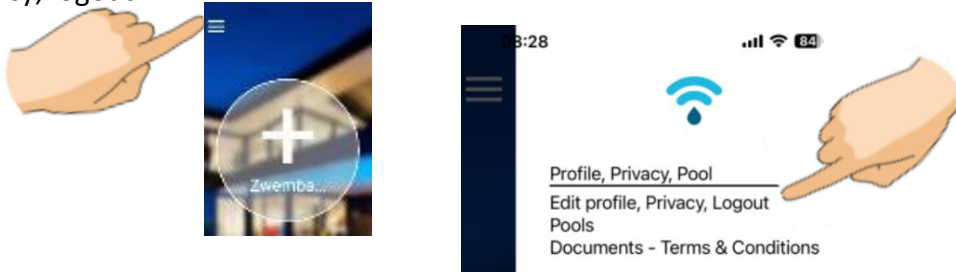

2. Click "Edit Profile"

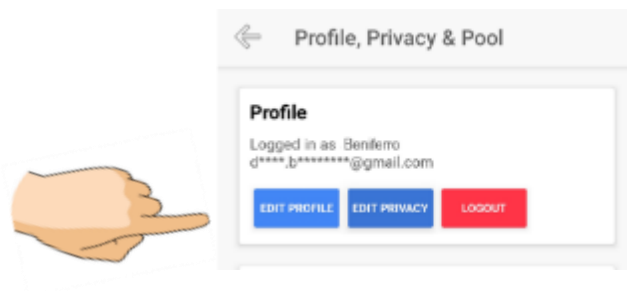

- 3 Change your personal information

- 4 Scroll down and click "Update" to confirm your changes

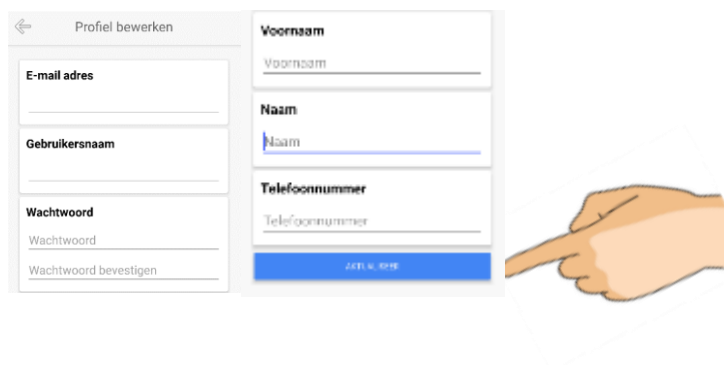

Privacy settings

1. Click on the top left corner to go to the open the navigation bar and tab “Edit profile, privacy, logout”.
2. Click "Edit Privacy"

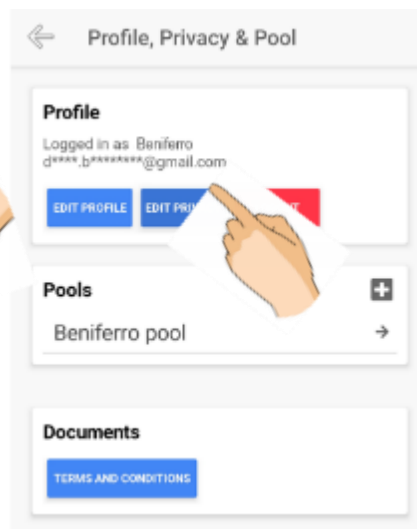
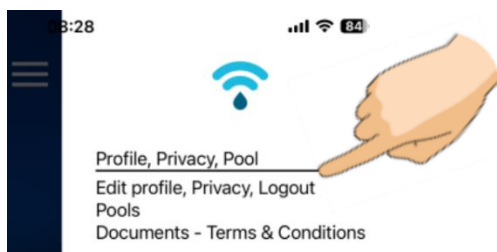
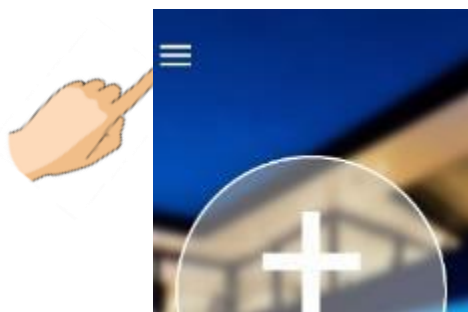

3. You can adjust your privacy settings by toggling the checkboxes.
4. Scroll down and click "Update" to confirm your changes



Please note: The above privacy settings may not display the complete list. They might not reflect the latest version. For the most up-to-date privacy settings, refer to the settings available on your phone.

1.4. Log out

1. Click on the top left corner to go to Profile, Privacy and Pool
2. Click "logout"

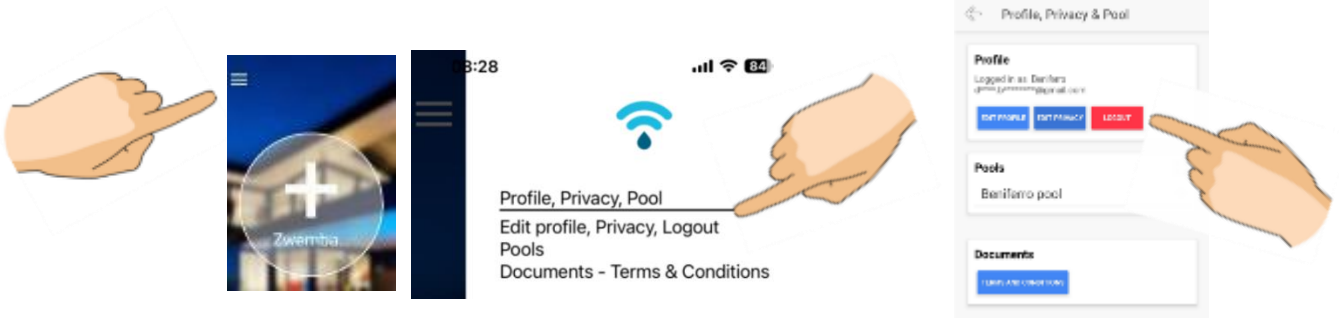

2 Pairing

2.1. What is pairing ?

Each Wifipool device emit a Wi-Fi signal. During the pairing process, we establish a connection between the Wi-Fi signal emitted by the Wifipool devices and the Wifipool cloud through our home network. We use our phone and ethernet connection (GEN2 only) to facilitate this connection.

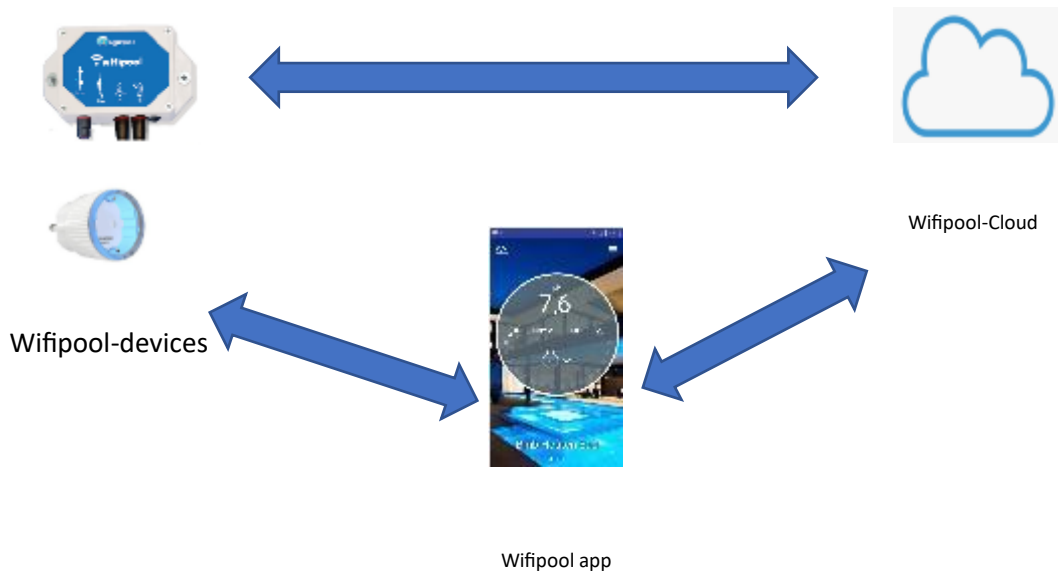

After pairing, the Wifipool devices will send data to the cloud, and they will receive instructions from the cloud. The communication occurs over the home Wi-Fi network and can be configured and monitored via the mobile phone.

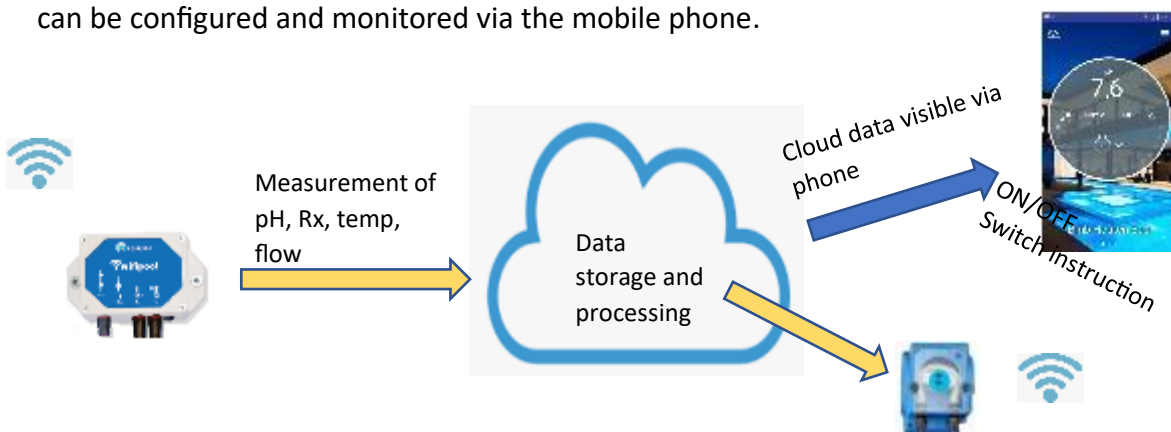

2.2. Problems with pairing

To ensure successful pairing, it's crucial to follow each step accurately. Both Android and iOS programmers have implemented intricate security measures, complicating the pairing process with several invisible security checks that must be confirmed.

The primary reason for pairing failures often stems from the instability of the home network. We strongly recommend conducting the pairing process indoors, close to the network source, and PRIOR to the physical installation of the devices. If you have a Gen2 Wifipool device, we recommend to pair via a ethernet connection.

Generally, pairing with Android proves to be easier compared to iOS. It's feasible to initially pair pool devices with an Android phone and then transfer ownership to an iOS device using the "Add user" feature (as mentioned above).

Once the pairing is complete, network stability becomes less critical. With Gen 2, these steps have been significantly streamlined, requiring only one-time pairing. Furthermore, it's not mandatory to pair via Wi-Fi; a cable connection is also an option, enhancing both the ease and reliability of the process.

2.3. Before pairing

If the board is not yet connected to a pool and no Ethernet connection has been established, the LED in the top right corner of the board will flash. In all other scenarios, it will not flash. This is the case when the board is already connected to a pool, either via Ethernet or WiFi. In this case, the LED will not flash, regardless of the type of connection (Ethernet or WiFi). It is important to note that if the LED on the board is flashing when the Ethernet connection is present, this does not mean that a connection to the Internet is available. If the Ethernet port is not flashing, no Internet connection is available.

Gen 1 (without) Ethernet

Led flashes when they are not paired and lights up 100% of the time after pairing. If they do not light up, they have no power, or the programming is wrong.

In previous generations, the red Shellys do not flash when they are not paired. However, the blue Shellys flash to indicate that they are ready to pair.

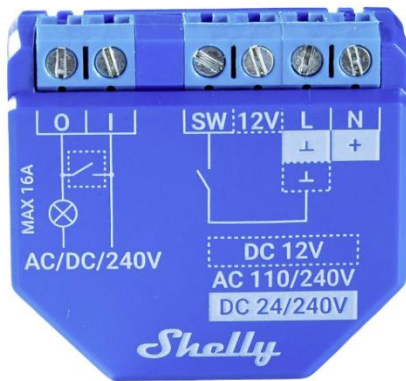

Both the small and the large plugs flash blue



First, ensure that the "Auto-join" feature in your Wi-Fi settings is activated. Without enabling this option on your smartphone, the network won't automatically reconnect, potentially causing issues when pairing your device. To activate this feature, navigate to the Settings app on your smartphone, then select "Wi-Fi" and tap the information ("i") icon. From there, toggle the "Auto-join" option to on, and proceed with the instructions below.

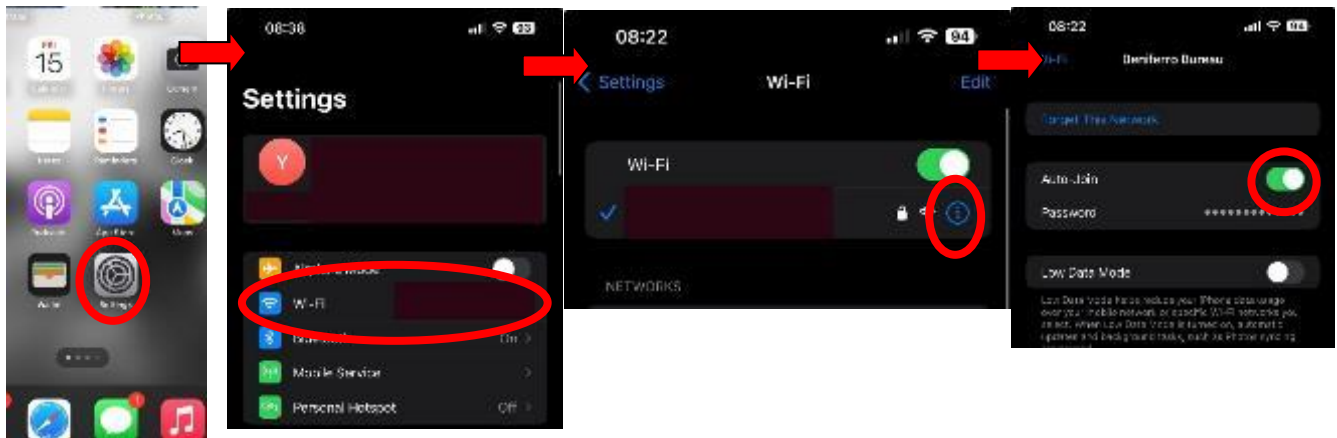

Before pairing with ethernet-connection:

1. Install the Wifipool app on your phone (as mentioned above).
2. Ensure you have an ethernet cable and connected to your device.



3. Make sure you have the instruction page (included with your order) with the device serial number and barcode. (See appendix 1).

Before pairing without ethernet connection:

1. Install the Wifipool app on your phone (as mentioned above).
2. Ensure you know the network names and password of your Wi-Fi network that you will use for your swimming pool.
3. Make sure you have the instruction page (included with your order) with the device serial number and barcode. (See appendix 1).

Additional Notes:

1. Take your time. The pairing process will take 5-30 minutes, depending on the number of devices to pair and the technique used.
2. Make sure the wifi products are used within the required technical specifications (see appendix 3), such as 2.4GHz wifi network, -20 to 70°C, dry environment, etc.
3. If the circuit board is not yet connected to a swimming pool and no Ethernet connection has been established, the LED on the top right corner of the circuit board will flash. In any other scenario, it will not flash. This applies when the circuit board is already connected to a pool, either via Ethernet or WiFi. In this situation, the LED will not flash, regardless of the connection type (Ethernet or WiFi). It is important to note that the flashing of the LED with the Ethernet connection on the circuit board is does not mea that a connection to internet is available. When the ethernet connector does not flas, no internet connection is available.

2.4.Pairing via ethernet

Pairing via ethernet is the preferred pairing method. The method is only available for Wifipool devices containing an ethernet connection, produced from 2024 onwards.

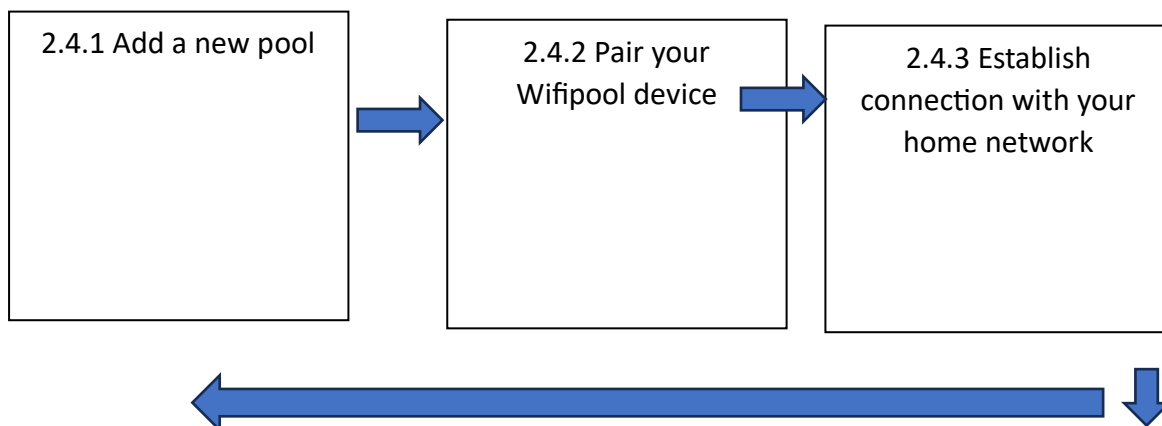

2.4.4 The device is added , automations are loaded and the phone returns to the Pool settings screen



2.4.5 Finalizing installation

2.4.1 Add new pool

Firstly, make sure you add a new pool, give it a unique name .

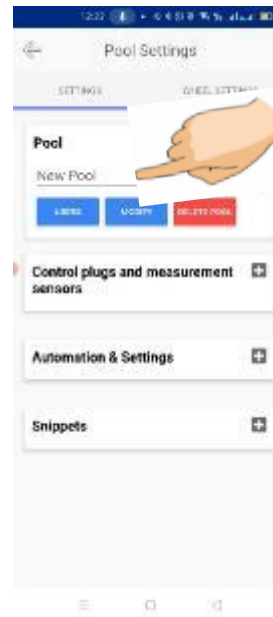
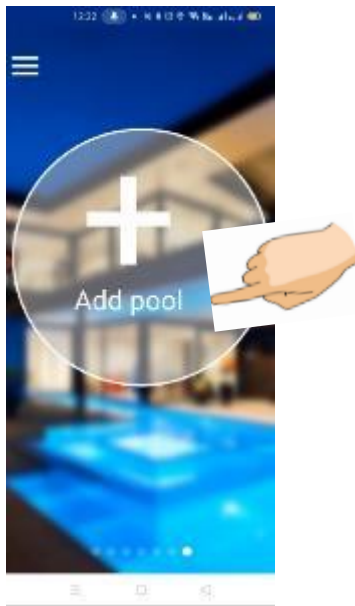

2.4.2 Pairing Wifipool device

Tap the plus icon next to "Control plugs and measurement sensors."

Always ensure that you connect your device using an Ethernet cable to establish a stable connection. If your router flashes a light, it indicates that the connection is successful.

Then, where it says "Scan the bar or 2D (QR) code on your device," tap "Start scanning" and proceed to scan the barcode on your device or on the "Startup information sheet" included in the box.

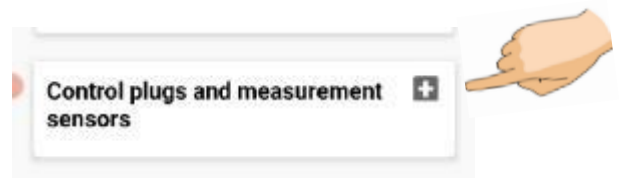

2.4.3 Connect to home network

The next step is different for Android vs IOS.

Android : you have to select your home network : the network which you will use for your swimming pool equipment.

IOS : You will have to enter the Swimming pool network name (SSID) and password manually.

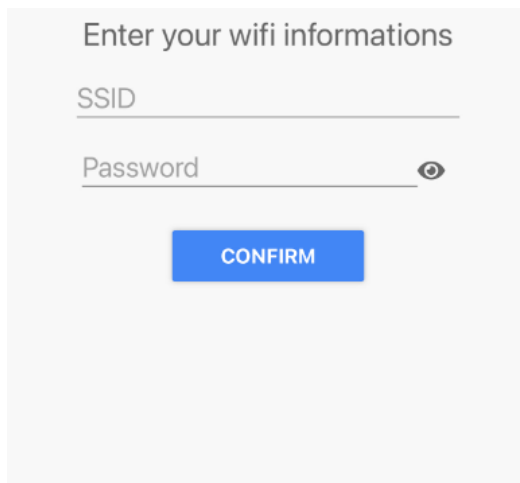
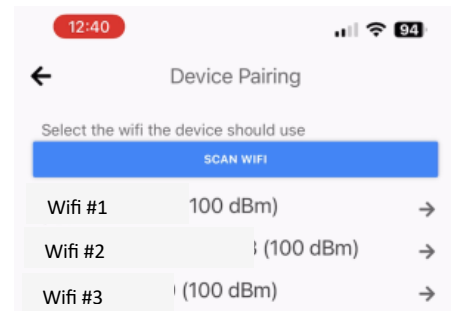
A screenshot of a web-based form titled "Enter your wifi informations". It contains two input fields: "SSID" and "Password". The "Password" field has a small eye icon to its right, indicating a toggle for visibility. Below the fields is a blue button labeled "CONFIRM".

Enter the correct password. Press the eye and check your password carefully, if you enter the wrong password, the app will go back to the main menu and your device will only remain connected as long as the device has ethernet connection. As soon as the ethernet cable is removed, connection will be lost.

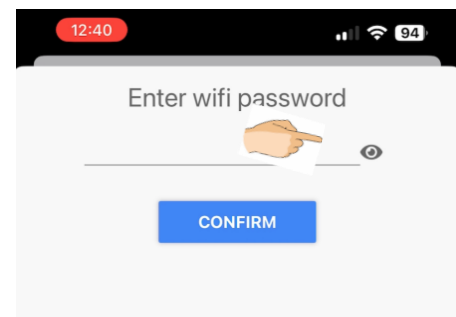

2.4.4 The device is added and the phone returns to the Pool settings screen

The app will return to the main screen. If not, close the app and open it again. A first device is now paired, and you will see the device in the Pool settings page.



2.4.4.1 Predefined Automation & Settings

With Gen 2, there may be predefined automation settings already configured. After installation, you can find them under "Automation & Settings." These settings are automatically activated once you start using them.

2.4.4.2 Wrong Wi-Fi password entered (ethernet)

In case your device is connected via ethernet, there won't be any error message if you have entered the wrong password. The menu will show a red signal next to your connection. Just unpair the device from the Wifipool app and go back to step 2.4.2



2.4.5 Finalizing installation

After the installation process is finished, go back to your pool settings.

Check if your control plugs and measuring modules are paired and functioning. If the indicator light turns green, it means they are paired. If it's red, it means there's (still) no connection. Always wait a moment until the indicator light turns green as it may take some time.



Note: Beniferro does not offer free technical support for pairing issues via Wi-Fi if you have an Ethernet device.

In case you have pH and RX probes, you need to calibrate your Wifipool device. This simple calibration process is explained in the quickstart manual of the equipment purchased

(More info about calibration, see chapter: Calibration) Once calibrated, you can seamlessly proceed with the physical installation of the device, ensuring optimal performance and accuracy in monitoring your pool's environment.

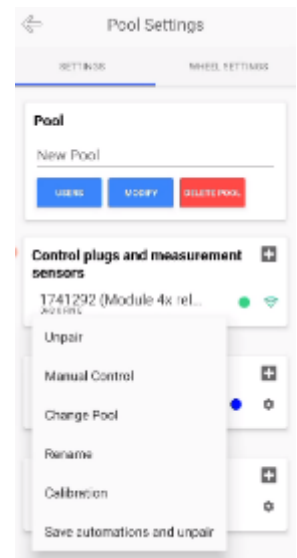

2.6. Pairing of the WIFIPOL-devices via Wifi for iOS devices.

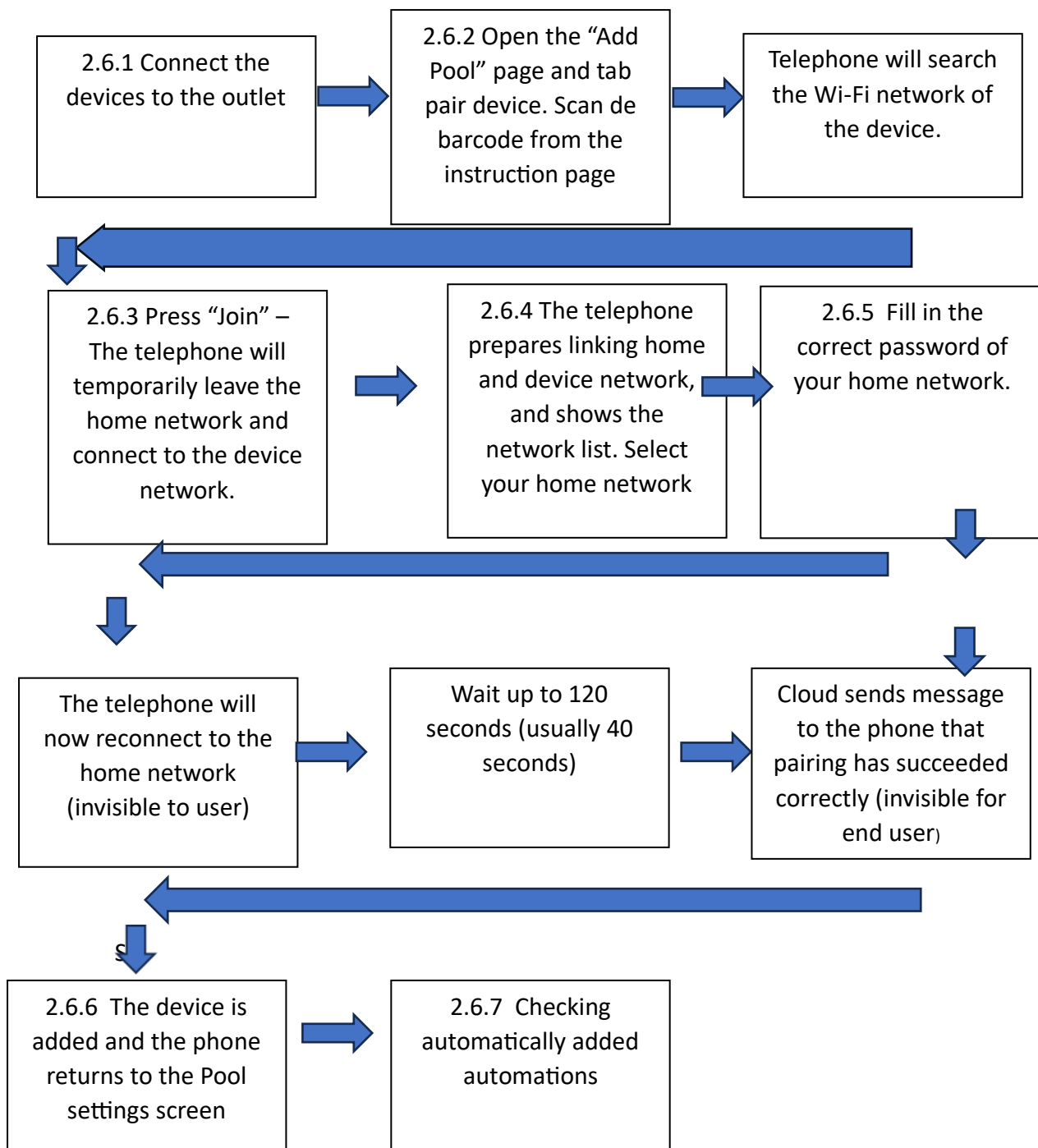

This pairing method is mandatory for Gen 1 devices (no ethernet connections) and is optional (but not recommended) for GEN 2 devices with ethernet connector.

The pairing needs to be completed for all the devices, before the pool automation can be entered into the system Please note: The manufacturer does NOT give free support for this pairing process if pairing via ethernet of webpage are available for your device.

2.6.1 Connect the devices to the outlet

After connecting the power, the Wifipool devices will emit a Wi-Fi signal. You will see the SSID of the devices in the available Wi-Fi list of your phone. The SSID is a combination of 6 and 4 letters/digits

In this example, there is a SSID for a pH pump, a salt electrolysis, a pH measurement and a Redox measurement.

Please note: If everything is paired successfully, you will no longer see these devices in your Wi-Fi settings

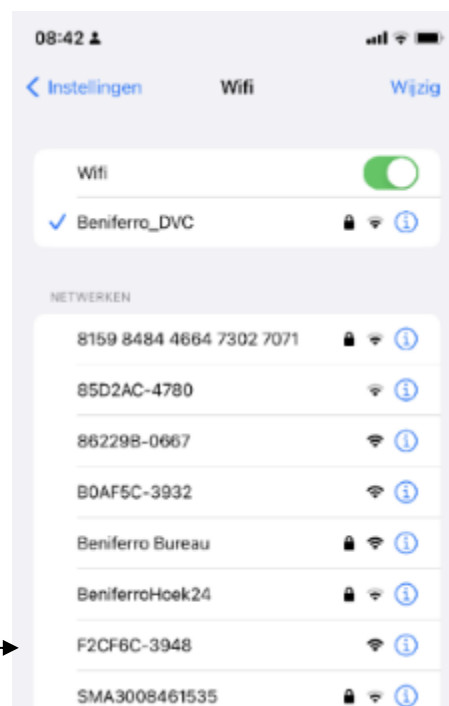

2.6.2 Connect the devices to your phone one by one. To do this, go to the pool settings on the Main screen and tick the Pool name (1), and press 2 on the "Control Plugs and Measurement Sensors" section and press + (press 2). Scan the first barcode on the instruction sheet that came with the products you purchased.

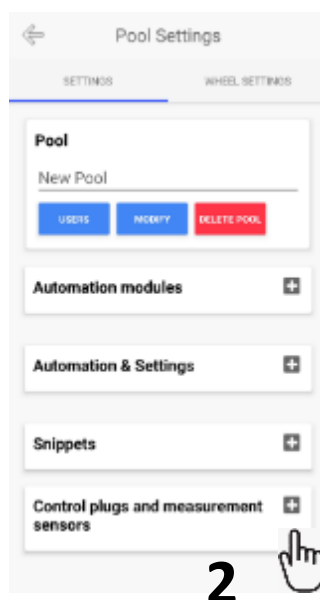

Start scanning



2.6.3 Press “Join” – The telephone will temporarily leave the home network and connect to the device network.

After scanning, a short notification will be displayed indicating that the Wi-Fi pool device is being connected to the phone.



The app will start searching for your WiFi networks, your device would no longer show the WiFi icon at the top right for a short moment.

2.6.4 The telephone prepares linking home and device network, and shows the network list. Select your home network : the network which is most active around your pool.

2.6.5 In the next step you have to select your home network : the network which you will use for your swimming pool equipment.

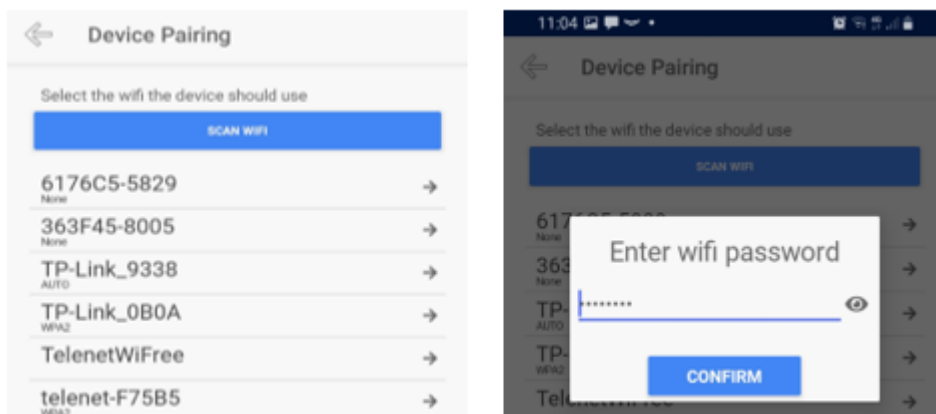

Enter the **correct** password Press the eye and check your password carefully, if you enter the wrong password, the app will go back to the main menu and show the following message: "The pairing process has failed".

The wrong password will now be saved, so if you reuse the saved password on a next attempt, the attempt will fail again.

If the correct password is entered, the phone will now start searching for the network and start the pairing process. During this period, do not interrupt the system, do not move the devices or the phone. Just be patient and wait. It takes usually +- 40 seconds to complete the process, but on other occasions it may take up to 120 seconds.

The last step of this process is a communication from the cloud to your phone (message not visible for end user), that the pairing process was successful.

2.6.6 The device is added and the phone returns to the Pool settings screen



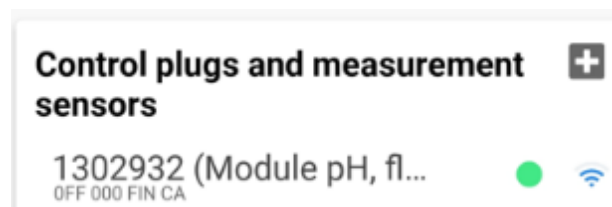



The app will return to the main screen. If not, close the app and open it again. A first device is now paired, and you will see the device in the Pool settings page.



2.6.7 Connect remaining devices

Repeat steps 2.6.1 to 2.6.6 until all devices are paired. You will now see your devices in the Pool settings page. A red circle behind the device indicates the device is not connected to the Wi-Fi. A green circle means the device is connected.

Control plugs and measurement sensors

1302901 (Module pH, fl... <small>OFF 000 FIN CA</small>		
1439745 (Module pH, fl... <small>OFF 000 FIN CA</small>		
1090507 (Plug 16A) <small>OGZ 000 FIN AA</small>		
1352157 (Module Temp... <small>OFF 200 FIN CA</small>		

2.6.8 Checking automatically added automations

Ensure to first verify whether any preprogrammed automations (appendix 1) are already present. This may be the case if you just paired a Gen 2 device. These will conveniently appear under the section titled “Automation & Settings”. Should you find that there are no automations listed, take the initiative to manually incRXorate them by scanning the provided barcodes. This step ensures comprehensive control and optimization of your device's functionalities. See the quick start-up manual of the equipment purchased.

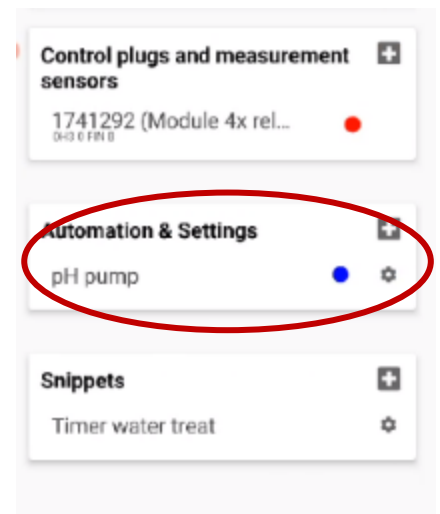

a. Pairing the WIFIPPOOL devices via WIFI on a Android phone

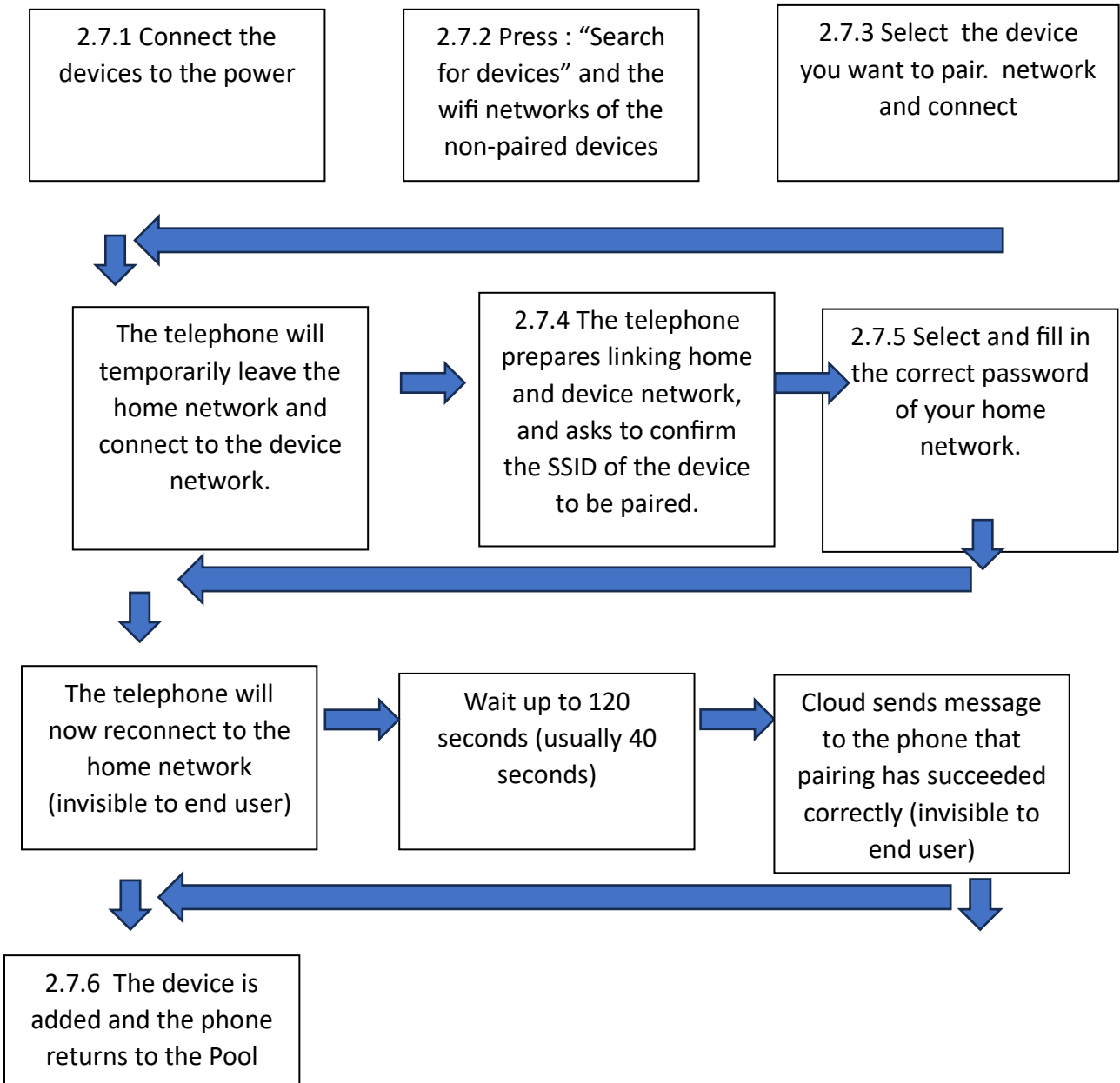

The pairing needs to be completed for all the devices, before the pool automation can be entered into the system

Attention : The manufacturer does NOT give free support for this pairing process if pairing via ethernet or webpage are available for your device.

2.7.1 Connect the devices to the power

After connecting the power, the Wifipool devices will emit a Wi-Fi signal. You will see the SSID of the devices in the available Wi-Fi list of your phone. The SSID is a combination of 6 and 4 letters/digits

- letters/digits
- In this example, there is a SSID for a pH pump, a salt electrolysis, a pH measurement and a Redox measurement.

Please note: If everything is paired successfully,

- you will no longer see these devices in your Wi-Fi settings

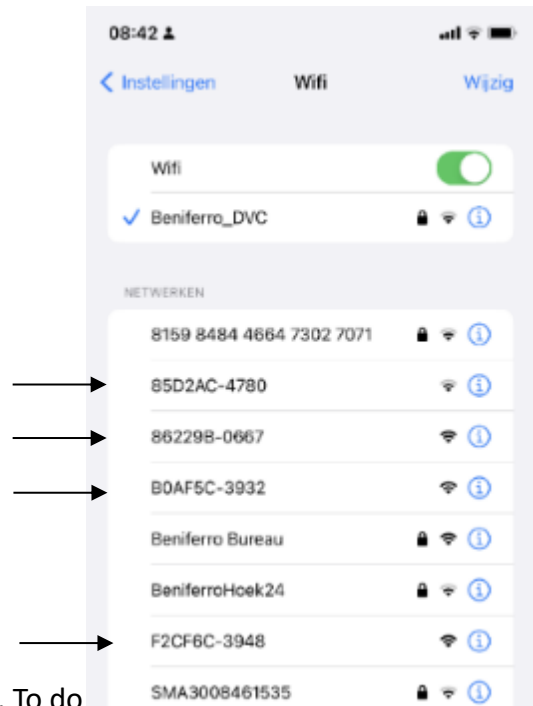

2.7.2 Connect the devices to your phone one by one. To do this, go to the Main screen and tick the Pool name (1), and on the "Control Plugs and Measurement Sensors" section press + (2). Subsequently start the « search for devices »(3), and select the device you want to pair (4).

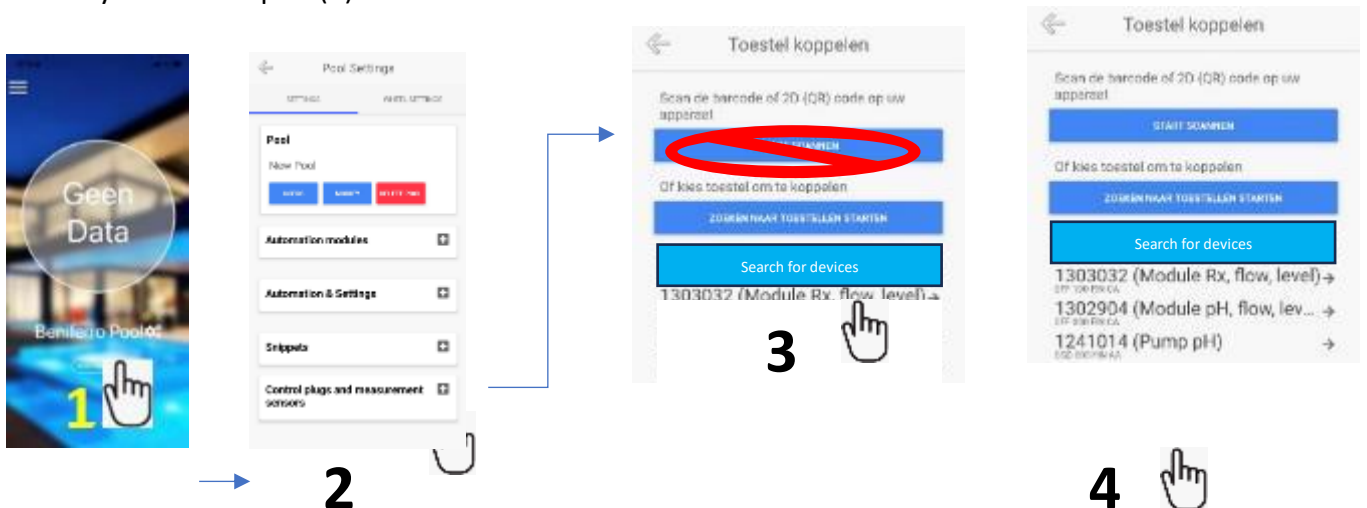

2.7.3 Press "Connect" – The telephone will temporarily leave the home network and connect to the device network.

2.7.4 The telephone prepares linking home and device network, and asks to confirm the SSID of the device to be paired.



2.7.5 In the next step you have to select your home network : the network which you will use for your swimming pool equipment.

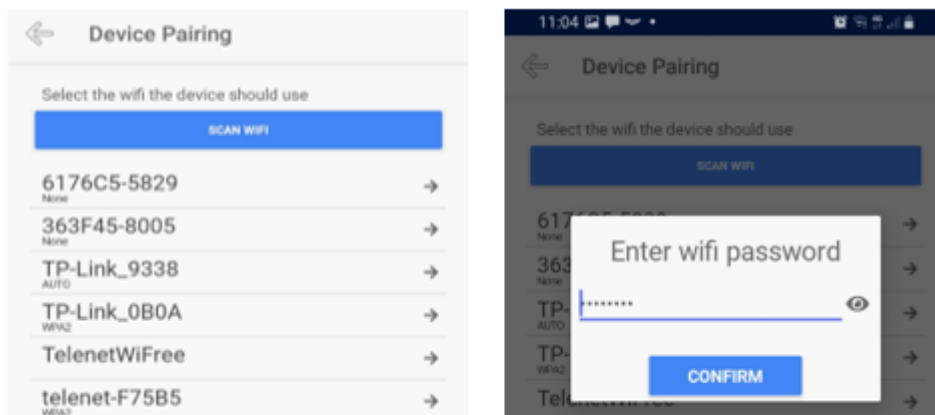

Enter the **correct** password Press the eye and check your password carefully, if you enter the wrong password, the app will go back to the main menu and show the following message: "The pairing process has failed".

If the wrong password is entered and saved, subsequent attempts with the same password will also fail. However, if the correct password is entered, the phone will initiate the network search and begin the pairing process. It's crucial not to interrupt the system during this period or move the devices or phone.

Please be patient and wait. Typically, this process takes approximately 40 seconds to complete, but in some cases, it may take up to 120 seconds. The final step involves a

communication from the cloud to your phone (a message not visible to the end user) confirming that the pairing process was successful.

2.7.6 The device is added and the phone returns to the Pool settings screen or to the main screen. If not, close the app and open it again. A first device is now paired, and you will see the device in the Pool settings page.

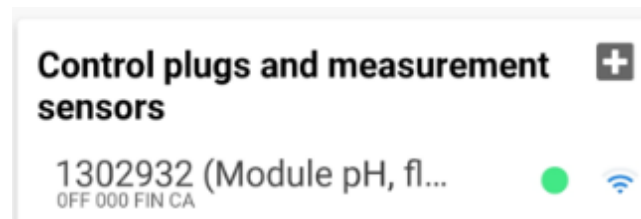

2.7.7 Connect remaining devices

Repeat steps 4.4.1 to 4.4.6 for each device until all devices are paired. Once paired, you will see your devices listed in the Pool settings page. A red circle behind the device indicates that the device is not connected to Wi-Fi, while a green circle signifies that the device is connected.

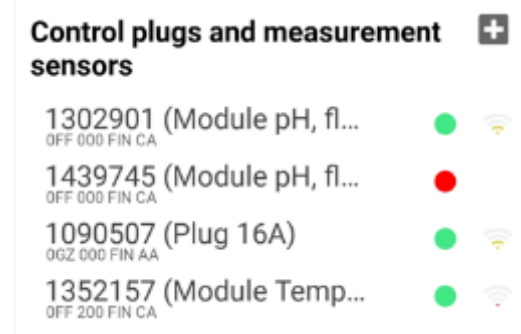

2.7.8 Checking automatically added automations

Ensure to first verify whether any preprogrammed automations (appendix 1) are already present. This is the case for GEN2 devices. These will conveniently appear under the section titled "Automation & Settings". Should you find that there are no automations listed, take the initiative to manually incRXorate them by scanning the provided barcodes. This step ensures comprehensive control and optimization of your device's functionalities. Barcodes and instructions are found in the quick startup manual of the device purchased.

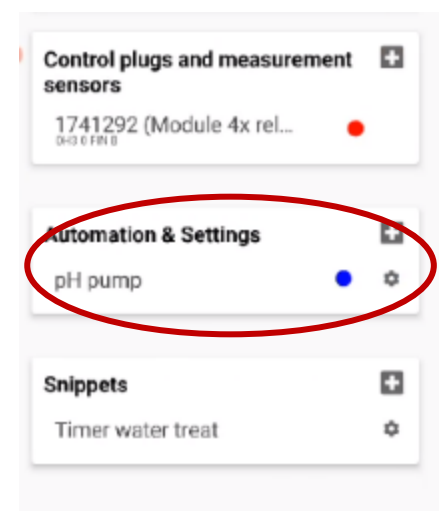

2.8 Pairing Problem solving IOS and Android

Step 2.6.6 / 4.5.6 Error: Wi-Fi connection failed - Possible causes:

- The home Wi-Fi network is not strong enough, unstable or absent in the zone in which you want to pair.

Solution for Gen 1:

Check that your phone is connected to your home network used for the pool. If not, select the appropriate network and ensure the phone remains connected during the pairing process.

Verify that the Wifipool network(s) in the format of 6 Characters/Digits - 4 Characters/Digits (e.g., 85C927-2343) is/are present in your phone's networks. Each unpaired device should display a network. After a power outage, it may take up to 3 minutes for the network to be visible.

If the device network is visible: Attempt to pair again from step 2.6.2.

If the device network is not visible, ensure the device is plugged in correctly (check the USB plug). If plugged in correctly, then reset the device by plugging and unplugging 7 times (each approximately 2 seconds). Wait until the Wifipool network is visible and your phone is connected to the correct home network, then attempt pairing again in the strong network zone from step 2.6.2.

If the error persists, contact your supplier after reading the section: 'What to do if I need to contact the supplier?'

Solution for Gen 2:

Check that your phone is connected to your home network used for the pool. If not, select the appropriate network and ensure the phone remains connected during the pairing process.

Verify that the Wifipool network(s) in the format of 6 Characters/Digits - 4 Characters/Digits (e.g., 85C927-2343) is/are present in your phone's networks, or for gen 2 devices, there can be more characters/digit – 9 digits and 4 characters (e.g., 975C93534-3850) . Each unpaired device should display a network. After a power outage, it may take up to 3 minutes for the network to be visible.

If the device network is visible: Attempt to pair again from step 2.6.2.

If the device network is not visible, ensure the device is plugged in correctly (check the USB plug). Unplug the device and wait 40 seconds and plug it back in. Wait until the Wifipool network is visible and your phone is connected to the correct home network, then attempt pairing again in the strong network zone from step 2.6.2.

If the error persists, contact your supplier after reading the section: 'What to do if I need to contact the supplier?'"

There is no assistance for WiFi connection problems, so pairing via ethernet is recommended

Step 2.6.6 / 2.7.6 Error: Pairing failed

Possible causes:

The home and/or device Wi-Fi network isn't strong enough or absent from the zone where you want to pair. Make sure your phone is near both home Wi-Fi and device Wi-Fi. Best is to do the pairing in-house before installing the pool equipment.

Solution:

1 Wait another 60 seconds after seeing the error message and verify if the device is not paired after all. If so, you will see your device on the Pool Setting page.

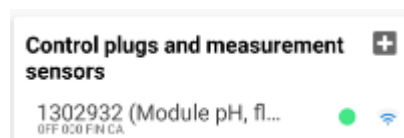

2. Check that the Wifipool network(s) in the formats 6 Characters/Digits - 4 Characters/Digits - For example, 85C927-2343 is/are present in your phone's networks. For each unpaired device, a network is visible. After a power outage, it takes up to 3 minutes for the network to be visible.

If the device network is visible : Try to pair again from step 2.6.2 / 2.7.2

If the device network is not visible, verify that the device is indeed plugged-in (also check that the USB plug is working correctly). If plugged in correctly, then reset the device by plugging in and unplugging 7 times (each +- 2 seconds). Then wait until you can see the Wifipool network and that your phone is connected to the correct home network, and try again to pair in the strong network zone from step 2.6.2 / 2.7.2

If the operation 7 times (each +- 2 seconds) has not worked, verify that the home network is indeed powerful at the location of the device. If the device is left for 15 minutes in the strong network zone to which it was paired (or partially paired), the device may reset itself.

If this error returns, contact your supplier after reading the section : What to do if I need to contact the supplier ?

Step 2.6.6 . 2.7.6 Error: Pairing Process failed - Possible causes:

Possible cause : The password you use for your home Wi-Fi network was entered incorrectly (and the wrong password was saved).

After a 120 minutes waiting time, a error message will display : The pairing process failed. Home network instability, or not strong enough in the pairing zone or too much distance between device, home network and phone.

Solution: Enter the password manually and verify the password when pairing the devices.

Step 2.6.6 / 2.7.6 : Error: "wrong password"

Issue 3: "Wrong Wifi password"

Possible causes:

1. You entered the wrong password
2. You switched the pairing methods from Ethernet to non-Ethernet

Solution:

1. Try pairing again and make sure to fill in the right password.
2. Reset the plug or the measuring box by disconnecting it from the power outlet for 30 seconds and then plugging it back in.

If you are connecting with Ethernet, make sure to plug in your cable before pairing. If you are connecting with Wifi, make sure there is definitely no Ethernet cable connected before pairing.

Step 2.6.2 / 2.7.2 : "Unable to connect to network 'Wi-Fi pool device name'

Possible causes:

The Wi-Fi pool device Wi-Fi network is not strong enough or absent in the zone in which you want to perform the pairing.

Your phone is too far from the Wi-Fi pool device



Solution:

1. Check that the Wifipool network(s) in the formats 6 Characters/Digits - 4 Characters/Digits - For example, 85C927-2343 is present in your phone's networks. For gen2 there can be more characters/digits. For each unpaired device, there is a network. After a power outage, it takes 3 minutes for the network to be visible.

If the network is visible: retry to pair from step 2.6.2 / 2.7.2 in a zone where all the networks (Wifipool networks and your home pool network) are strong.

If the device network is not visible, verify that the device is indeed plugged-in (also check that the USB plug is working correctly). If plugged in correctly, then reset the device by plugging in and unplugging 7 times (each +- 2 seconds). Then wait until you can see the Wifipool network and that your phone is connected to the correct home network, and try again to pair in the strong network zone from step 2.6.2

If the operation 7 times (each +- 2 seconds) has not worked, verify that the home network is indeed powerful at the location of the device. If the device is left for 15 minutes in the strong network zone to which it was paired (or partially paired), the device may reset itself.

If this error returns, contact your supplier after reading the section : What to do if I need to contact the supplier ?

Step b2 2.6.2 : Home Wi-Fi network is not visible

Solution: On iPhone the network screen doesn't always show up over the full length of the device. Scroll down the network list to check if you can see the network.

Step b2 2.6.2 : Wi-Fi network are not displaying correctly (undefined NaN dBm)

Solution: press the "scan Wi-Fi" button multiple times until your networks are accurately detected and displayed.



Step 2.6.2 / 2.7.2 : "The device cannot be paired because it is already connected to another pool"

Solution:

Check if you can see the device in the pool settings page . If this is the case, everything is fine.

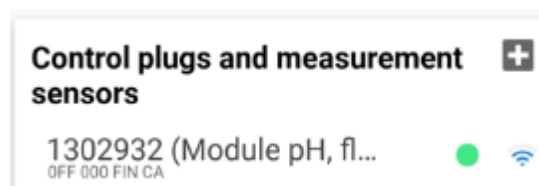
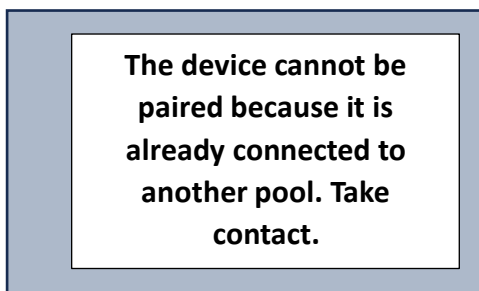

If the device network is not visible, verify that the device is indeed plugged-in (also check that the USB plug is working correctly). If plugged in correctly, then reset the device by plugging in and unplugging 7 times (each +- 2 seconds). Then wait until you can see the Wifipool network and that your phone is connected to the correct home network, and try again to pair in the strong network zone from step 2.6.2 / 2.7.2

If this error returns, contact your supplier. It can remotely perform an additional reset of the Wi-Fi pool device.

What to do if I need to contact the supplier ?

Please act as follows:

1. Plug in and out the devices that are not working
2. Please send a photo of the barcodes provided for pairing. These can be found on the Connect Go/Pro control box or on the pairing instruction sheet included with the delivery.



3. Send a screenshot with all your home networks. All devices should be shown on the screenshot.

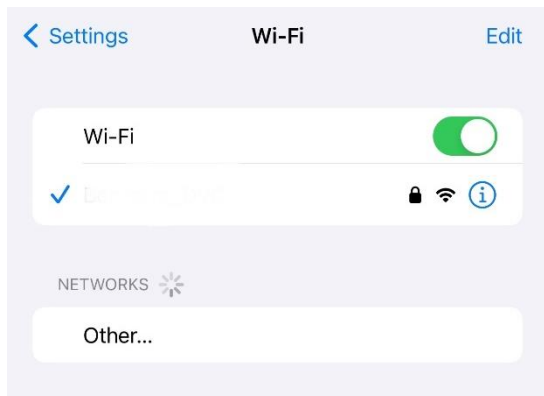

Please wait until all the networks are displayed, and then send a screenshot of the entire list.

4. Send a screenshot of the pool settings where we can see the control plugs and measurement sensors that are paired

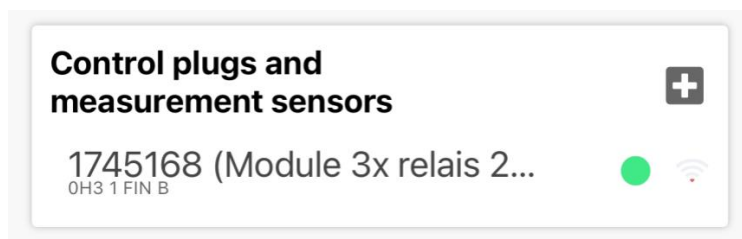

5 Add info@beniferro.eu as user to your pool, promote 2 times to the level of co-owner.

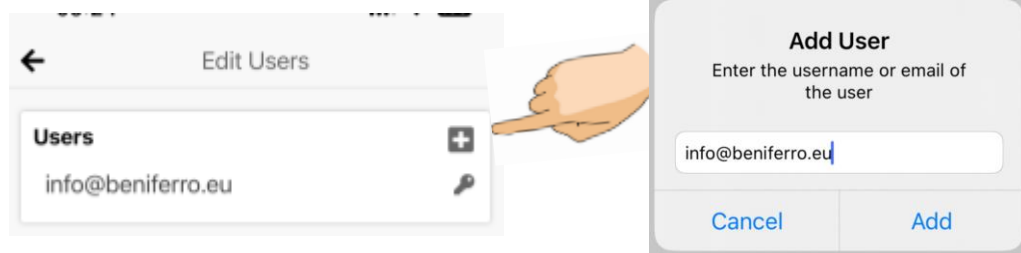

See section 3.1.1.2.1 below

Please send this information along with the problem description and the name of your pool to info@beniferro.eu.

3. Using the Wifipool app

3.1. Pool Settings

The Pool settings page is the page with which you will add new equipment (such as plugs and measurement boxes) , and define how your pool will be controlled. Via this page you can add additional users, edit the pool characteristics and verify the status of devices and automations.

There are 2ways to enter the Pool settings page :

From the main page click directly on your swimming pool name or on the 3 bars in the top left corner

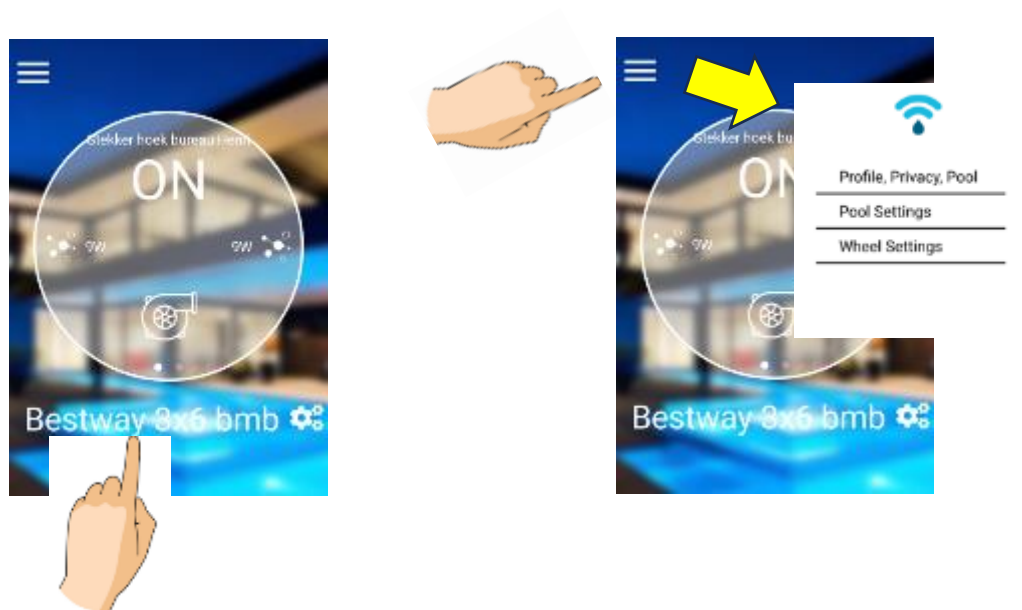

3.1.1. Pool

3.1.1.1. Pool Name

Give your swimming pool a name. In case you share your pool with other people (see “users”, it is important to choose a recognizable and original name. Type in your new pool name in the text field.

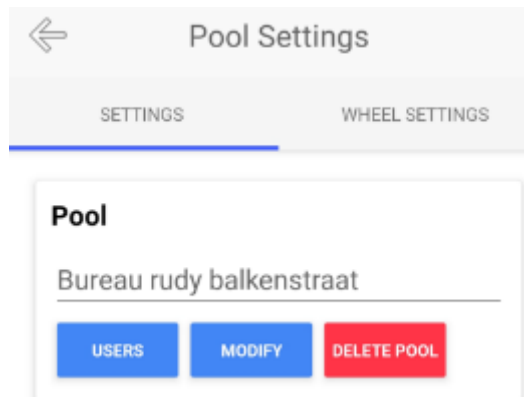

3.1.1.2. Users

3.1.1.2.1. Adding users

Via the "Users" tab, you can let other people watch or control your pool.

Go to the pool settings page and select users

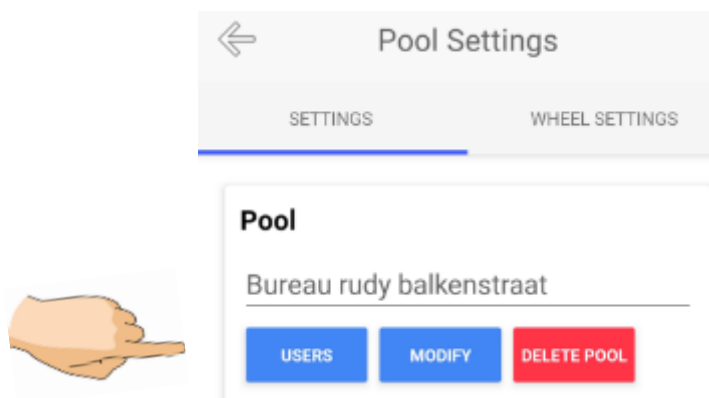

You can now add users to your pool. Click on the little plus symbol in the right top corner of the screen. The user is directly added to the pool. This user is "Read only" (3.1.1.2.1).

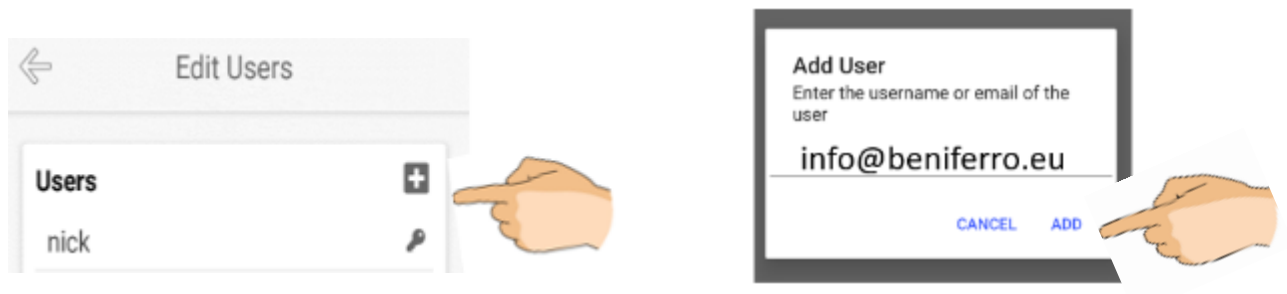



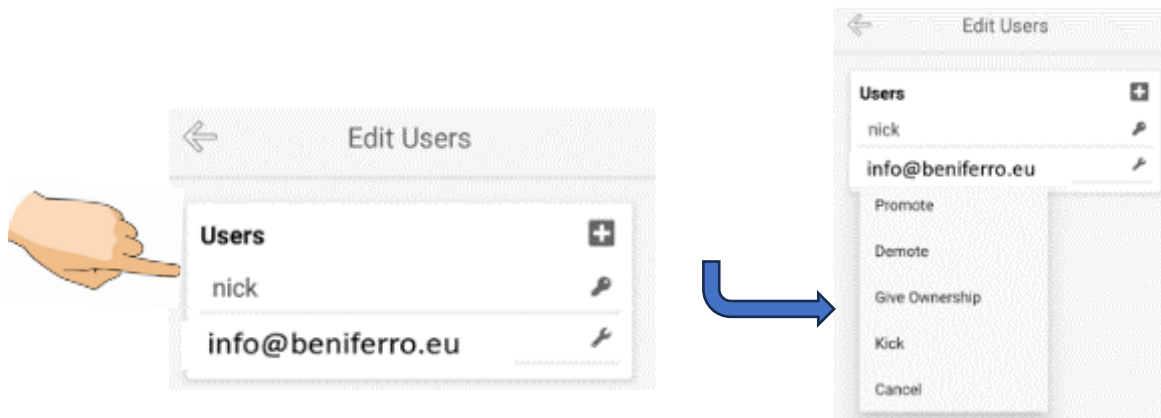

A popup window appears where you can type in the Wifipool username of the person you want to add.

3.1.1.2.1. Manage user rights

Click on the name of a user from the menu



There are 4 levels of restrictions you can add for each User

-  Owner : can control the swimming pool, add, promote, give ownership and kick out users
-  Co-owner : can control the swimming pool and add and promote users
-  Partner : can look at the swimming pool and receive notifications
-  Read only

Be aware that once you give up your own rights as an owner and this user now has the rights to kick you out as a user.

By promoting info@beniferro.eu to the level of co-owner, you can give the manufacturer access to your pool. This is a helpful feature in case help or troubleshooting is requested. In this case, make sure your pool has a recognizable and original name.

3.1.1.3. Modify Pool Characteristics

By pressing the modify button, you can edit and change your Pool characteristics. Filling in the Pool characteristics (such as Pool volume / Pool type...), will allow the app, to send you advice on your pool.

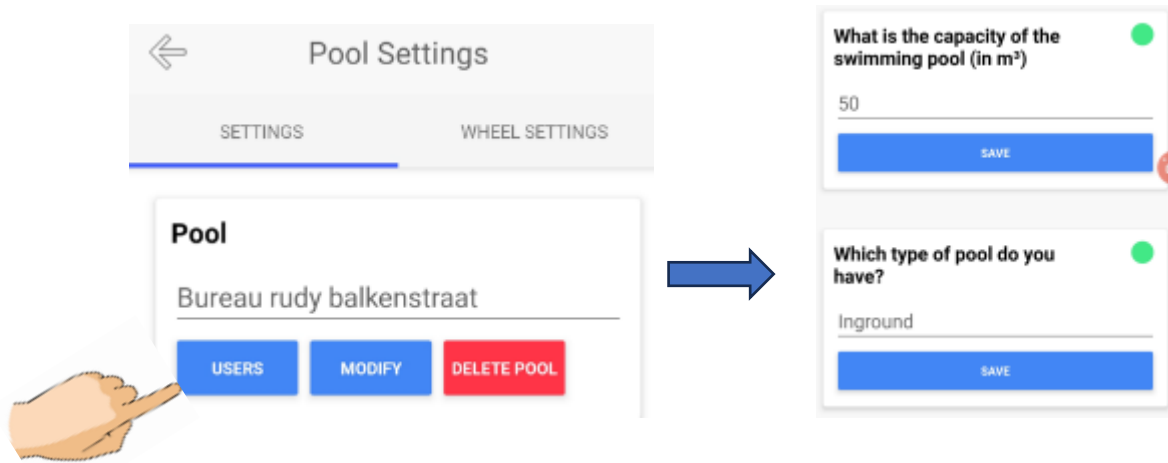

3.1.1.4. Delete Pool

Using this option will fully delete your pool, all pairing and automations. This action cannot be restored.

Please note: if you happened to delete your pool by accident. You have to manually reset your devices connected to the swimming pool.

3.1.2. Control plugs and measurements

The “Control plugs and measurements” section allows the user to have a quick overview of the devices in the swimming pool and their connection to the wifi network.

In addition, some direct controls such as calibration, manual control etc. are initiated via this section.

Before a device can be used, it needs to be paired with your home network and telephone. The pairing process of the control plugs and measurement devices has been described above.

After pairing, all devices are listed. The green circle indicates the device is connected to Wi-Fi, a red circle is not connected to the Wi-Fi. The number in front of each device is the serial number of the device.

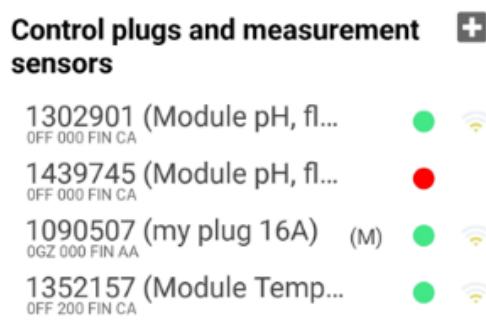

3.1.2.1. Unpair

The unpair / delete option will „delete“ a device, and make it available for other users / other swimming pools; Tick on the device name in “control plugs and measurement sensors”, followed by “unpair or delete”.

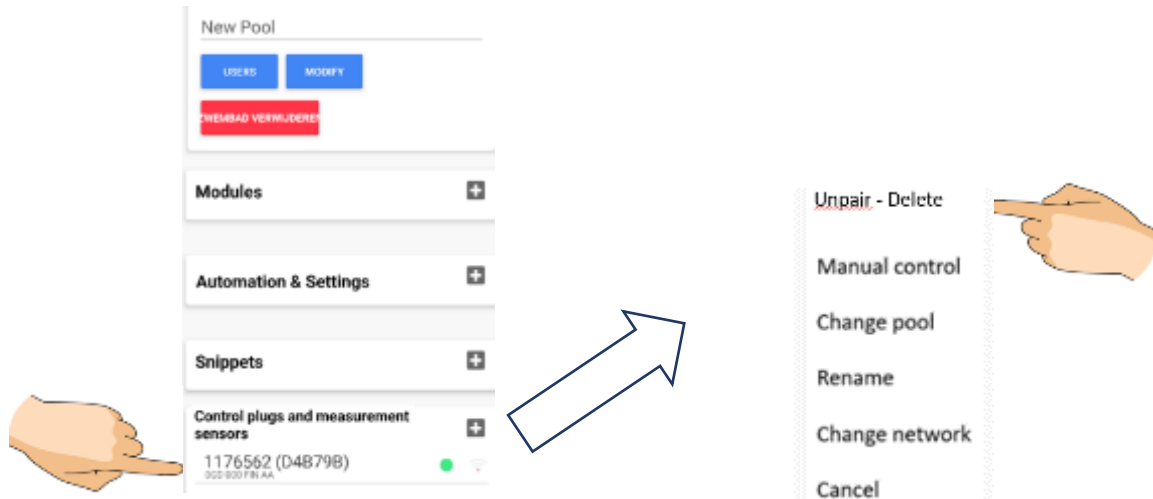

3.1.2.2. Manual control

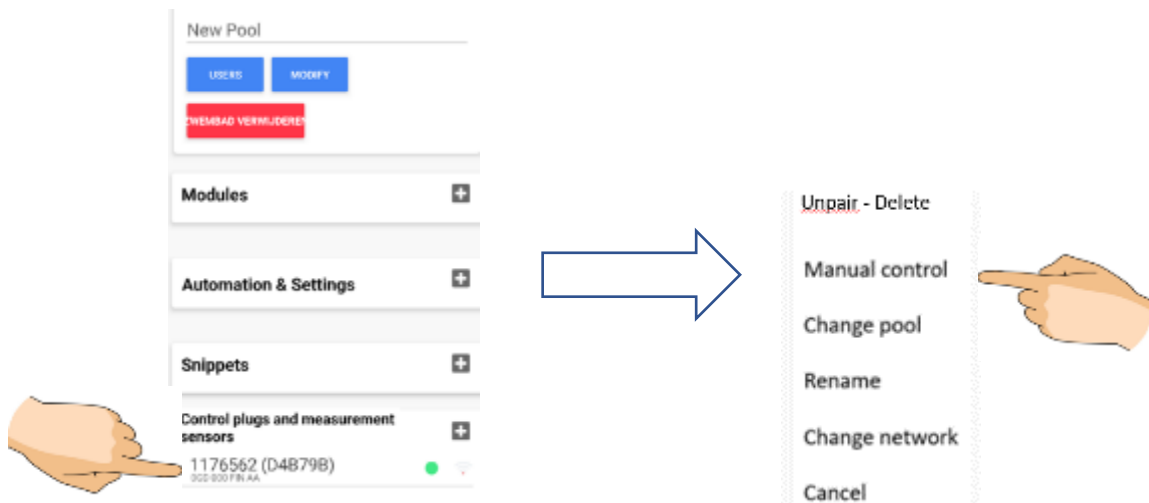

Click on manual control to switch from automatic to manual control. When using manual control, the owner, co-owner and partner of the Wifipool account, can start and stop manually the plug or smart switch. Although manual control can be helpful, it also contains risks. In case the pH peristaltic pump is started manually, it will keep on dosing liquid into the pool, regardless if this is needed or not.

Therefore, it is necessary to acknowledge that you have been informed of the risks associated with manual control, before you can access the control itself.

Once entered the manual control, it is possible to return to automatic via the green “switch to automatic button” . You can toggle the pump (or other device) on or off by tapping or swiping the grey toggle to the left or to the right.

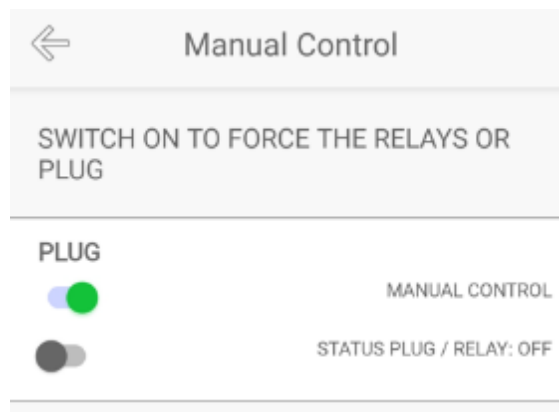

On the Pool setting screen, plugs and smart switches in manual mode, will be indicated with a “M” .Upon hitting the device name, a menu will unfold, by which it is possible to return to the automatic mode



3.1.2.3. Rename

Select Rename and enter in the new name for your plug. It is advisable to select a name which makes it clear which equipment this plug is controlling (eg Filter pump, pH peristaltic pump)

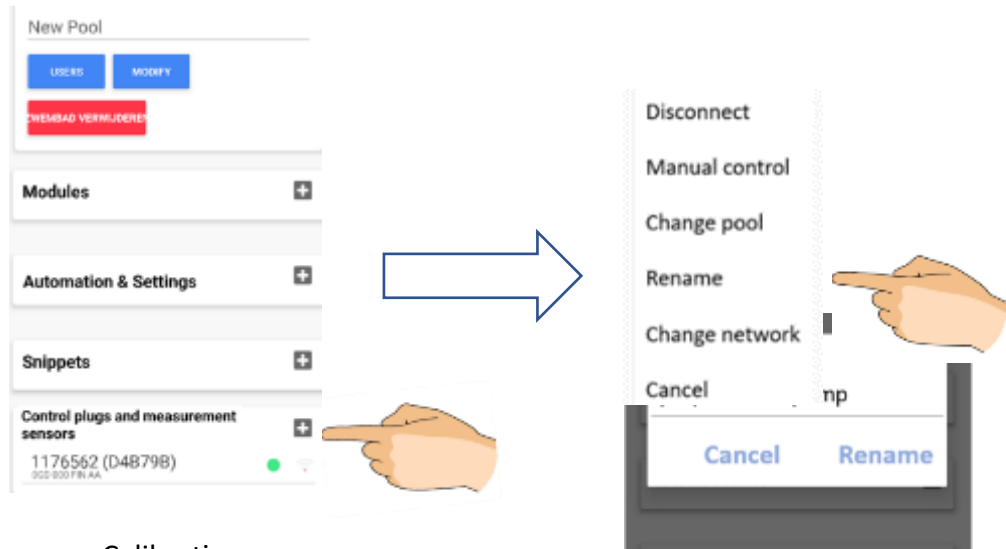

3.1.2.4. Calibration

To initiate the calibration process, tap on the pH or RX module line ("Module" in title) is between brackets. Once selected, the menu options will unfold, revealing a tab labeled "Calibration." Ensure you are prepared to remove the pH or RX probe from the installation and place it in the pH or RX calibration solution.

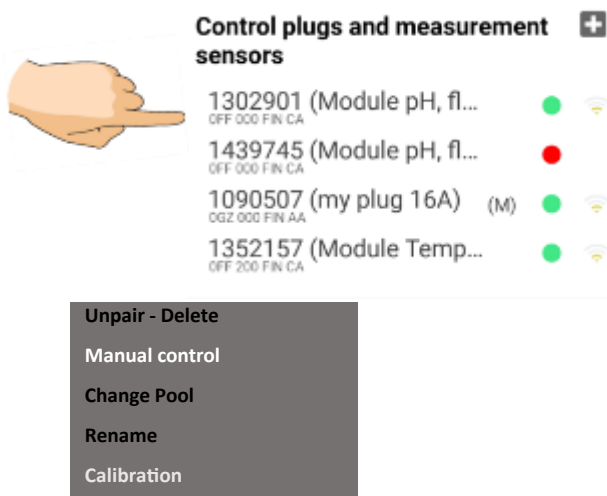

Follow the instructions on the screen to proceed with calibration.

3.1.2.5. Change Pool

3.2. Automation & Setting

With Gen 2, preprogrammed automations streamline the process by eliminating the need for manually adding automations check appendix 1 for extra info.

An automation makes the link between the measurements of a pool and a smart plug (or smart switch). Using the measurement results, we will start-stop a plug or smart switch. It is also possible to set up a timer and/or notifications in the automations

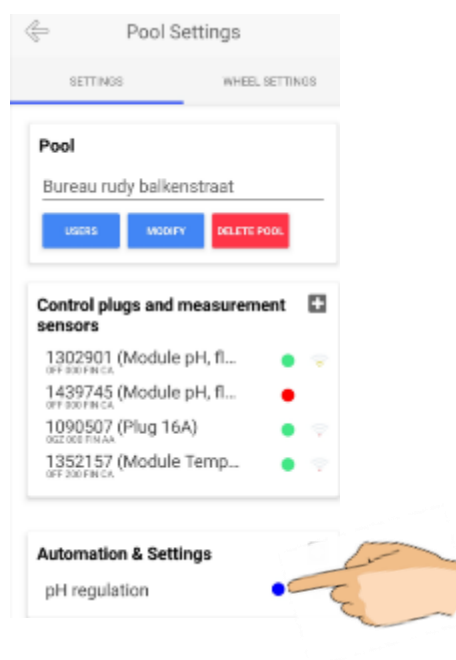

A blue circle behind the automation indicated the automation is not active because the target value has been reached, or because one of the conditions (e.g. a timer) stops the automation from running.

A green circle indicates the automation is running (e.g. pH pump is running).

The Wifipool automations have a feature called « duty cycle » .

A duty cycle of 30% / 60 seconds means that the power to the device being controlled will be on during 18 seconds each 60 seconds.

By enabling the duty cycle, it is possible to slow down the dosing of peristaltic pumps, enabling efficient water treatment in small volume pools and spas.

Attention:

The duty cycle parameter should not be adjusted by standard users. Altering this value can significantly disrupt the functionality and accuracy of your dosing device. Any modifications to these settings should only be performed by qualified personnel. Therefore, we strongly advise against making any changes to these parameters.

The Duty Cycle should never be used in combination with salt electrolysis or other pieces of equipment containing a control PCB.

The software is programmed with hysteresis. Hysteresis is a feature that helps prevent the device from switching on and off too frequently. Think of it like a buffer zone: it allows the device to wait for a small range before making adjustments, ensuring smoother and more stable operation. For example, in our system, the hysteresis for pH is set at 0.01, and for redox, it is set between at 10. This means the device will only make changes if the pH or redox levels move beyond these small ranges, preventing constant switching and ensuring accurate control.

3.2.1. Existing automation module

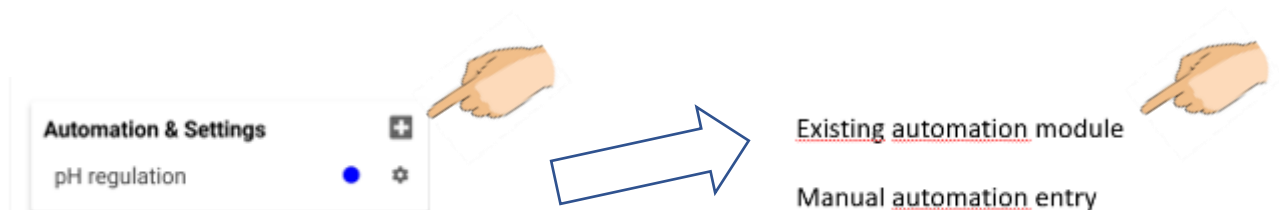

The existing automation module option allows the user to use a pre-defined automation module. The customer can choose between selecting a pre-defined automation or can scan a barcode from the manual joint to the product purchased.



Scanning the barcode or pressing the “Water treatment Liquid chlorine and acid for swimming pool, flow and level switch” link will have the same result : the full pre-defined automation will be installed on your swimming pool.

In this example, the regulation will be as follows :

pH and RX regulation (pH master)
 Daily Scheduler for water treatment between 9:30 and 17:30
 Notification sent to the phone if pH or RX is very high (>9) or low (<5.5) or no flow or low level.
 Safety stop if no flow or pH > 9 or RX >950 or level switch = low.

Appendix 1 gives an overview of the automation barcodes available.

The pre-defined automations contain all elements necessary to control correctly the equipment, including timers, notifications, safety stops if pool values deviate abnormally etc ...

We recommend to use a pre-defined automation and, if desired, adjust the values to your wishes. In the example below : press the « 7.6 » to modify the pH target value.

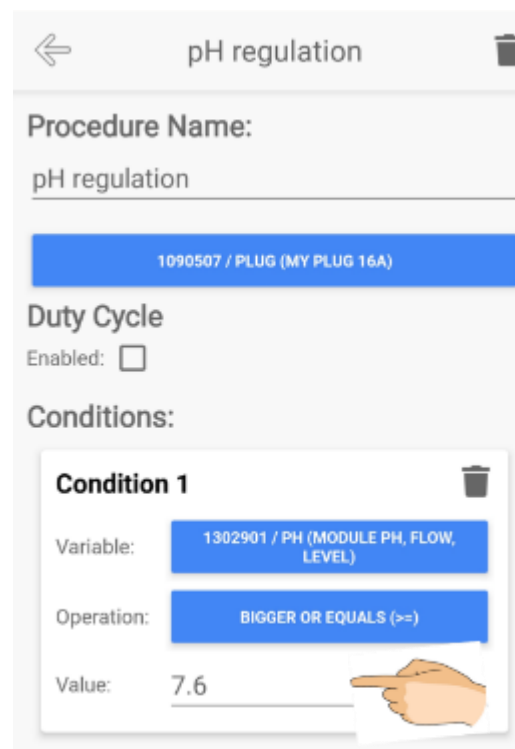

3.2.2. Manual automation entry

The automations can be entered manually as follows :

- Click on the **+** sign in the right corner, next to automations your pool settings tab which opens the “new procedure” page. Enter a name for you procedure

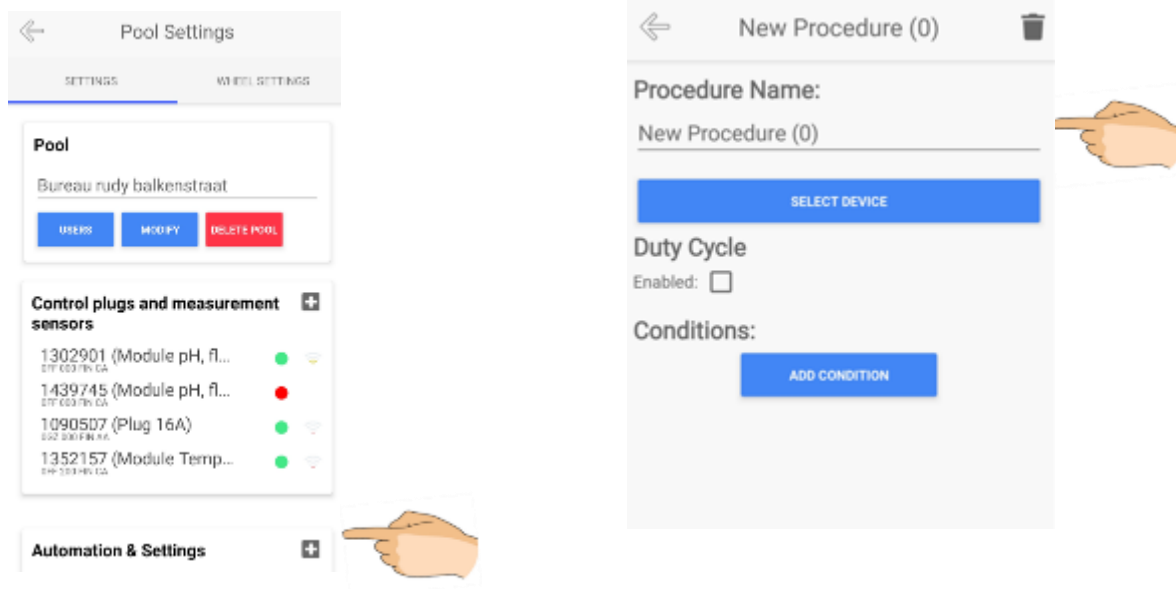

- Select the Wifipool device (plug , smart switch (or equipment containing a smart switch such as a peristaltic pump) you want to start and stop.

OR

- Select Push notifications to define de conditions under which you have to receive a notification.

In the example below, we create the procedure “pH control” by selecting our pH peristaltic pump as action device



- Define the condition

By pressing the “Add condition” button, we can select conditions at which the pH pump has to turn on. In our pH control example, we choose to start the pH pump (when the pH is larger or equal to (\geq)7.6 AND (by adding once again a condition) the flow switch detects flow.

In the example below, the pH pump will run only if $\text{pH} \geq 7.6$ AND the flow switch detects flow.

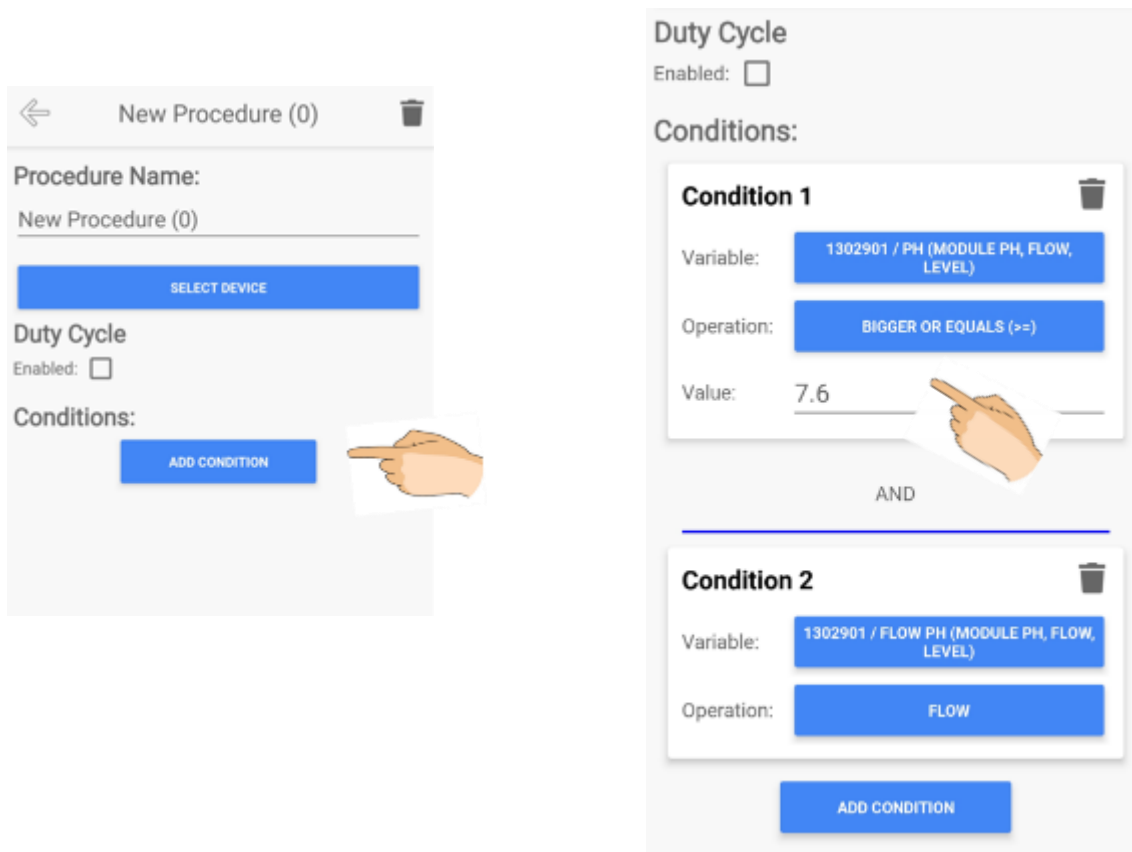

A unlimited number of conditions can be added

- Duty cycle:

With the duty cycle you are able to select the intensity for your device (output) to run on.
For example: Duty cycle % 30 Period (s) 60

This means that during the period of 60 seconds your device will run for 18sec in total (30% of the interval)

Click on enabled if you would like to use the duty cycle and in the values for your desired duty cycle

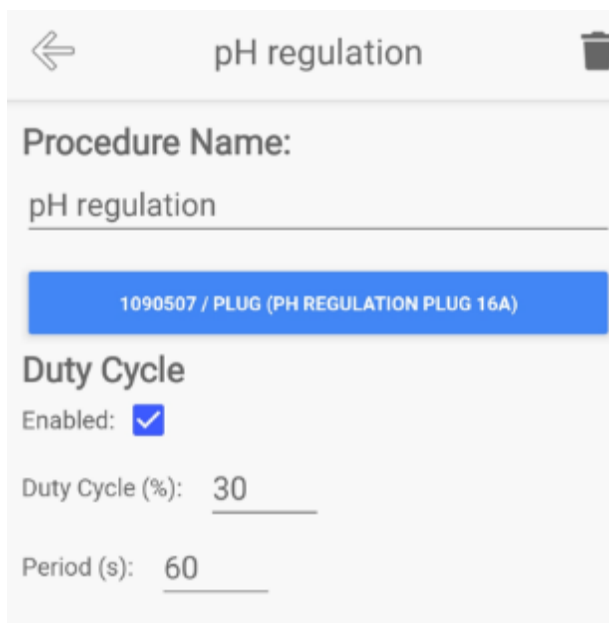

The screenshot shows a mobile application interface for 'pH regulation'. At the top, there is a back arrow on the left, the title 'pH regulation' in the center, and a trash icon on the right. Below the title bar, the 'Procedure Name:' is set to 'pH regulation'. A blue button below this contains the text '1090507 / PLUG (PH REGULATION PLUG 16A)'. Underneath, the 'Duty Cycle' section is visible, with 'Enabled:' checked by a blue checkmark. The 'Duty Cycle (%)' is set to '30' and the 'Period (s)' is set to '60'.

In our example , the pH pump will run 30% of 60 seconds (= 18 secondes) per minute IF the pH > 7.6 AND flow is detected.

The duty cycle is typically used to reduce the dosing speed of peristaltic pumps.

Attention : never use the duty cycle with instruments which start up via a control PCB such as a salt electrolysis, frequency regulator, heat pump etcThe duty cycle will cause the instrument to switch on and off very frequently. This may cause electrolic failure.

- Timer - scheduler

When selecting a condition, “Scheduler” is a option. When selecting the scheduler, a weekly schedule can be filled in.

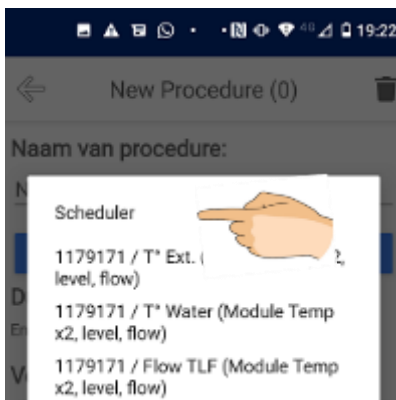

A weekly schedule will open, in which different time slots per day can be programmed

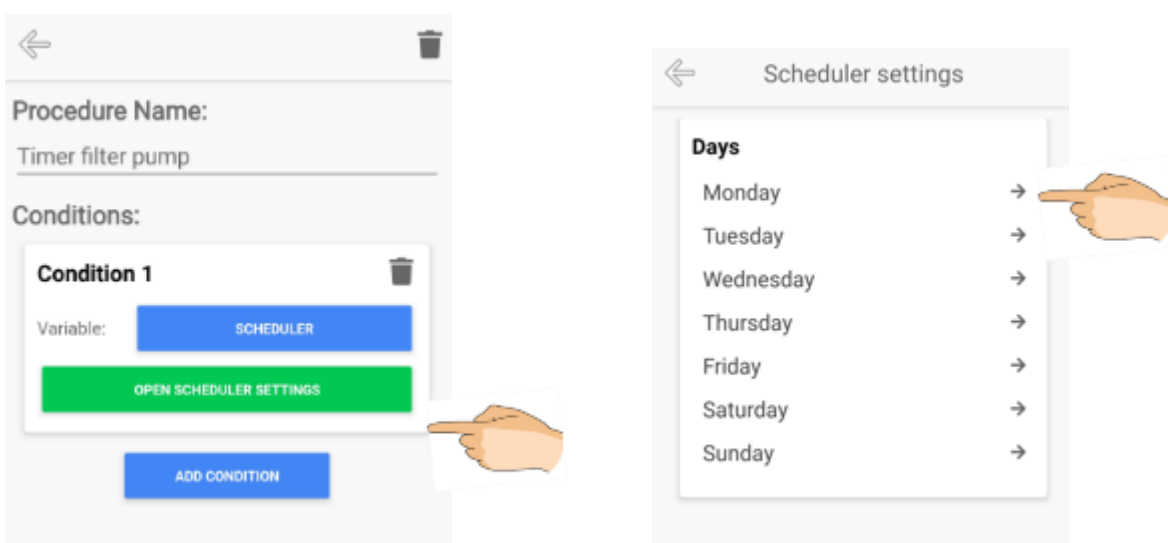

A alternative option for the scheduler, is to define a scheduler within the Snippets, and then selecting the Snippet as a condition. This has the advantage that the same timer can be used for several plugs / smart swtichtes.

3.3. Snippets

Snippets are “schedulers » which repeat themselves in several automations. As an example : the „Filter pump scheduler“, can be used for the filter pump as well as for the UV lamp plug.

Activate the Snippets by pressing the + sign, and complete and save the snippet just as described above in the “timer“ section

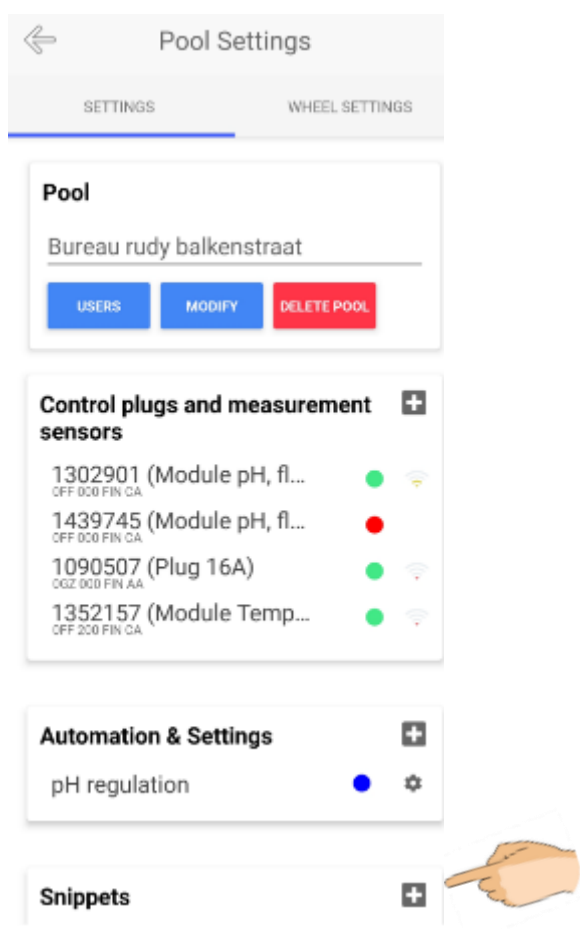

3.4. Notification scheduler

Adding a notification schedule

1. Scroll down to snippets. And press the plus icon. This will add a new snippet. Press the new snippet and change the “Procedure name” to something more appropriate (e.g. Notification scheduler). And press “Add condition”.

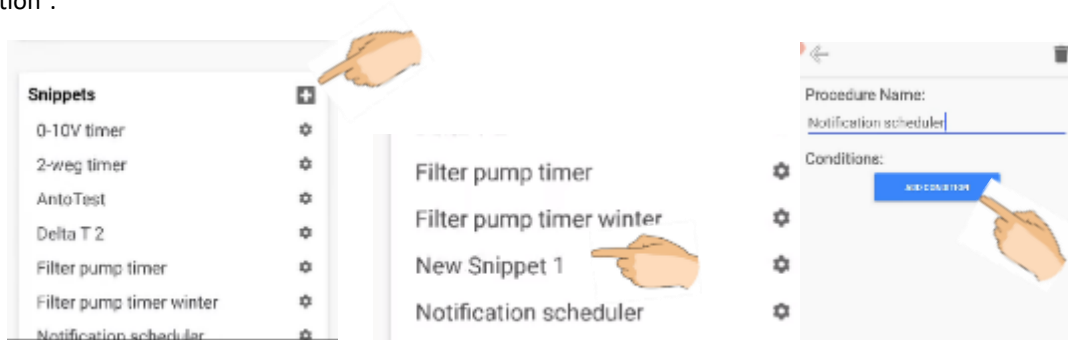

2. In the newly added condition just press “Select measurement”. All the way on top you’ll see an option with “Schedule” just select this.

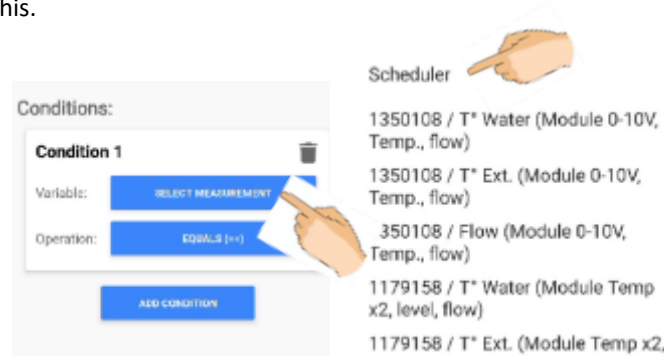

3. You can open the schedule settings now by pressing “Open schedule settings”. All days of the week will be displayed. Open for example Monday, and tab “add more” to add a new interval.

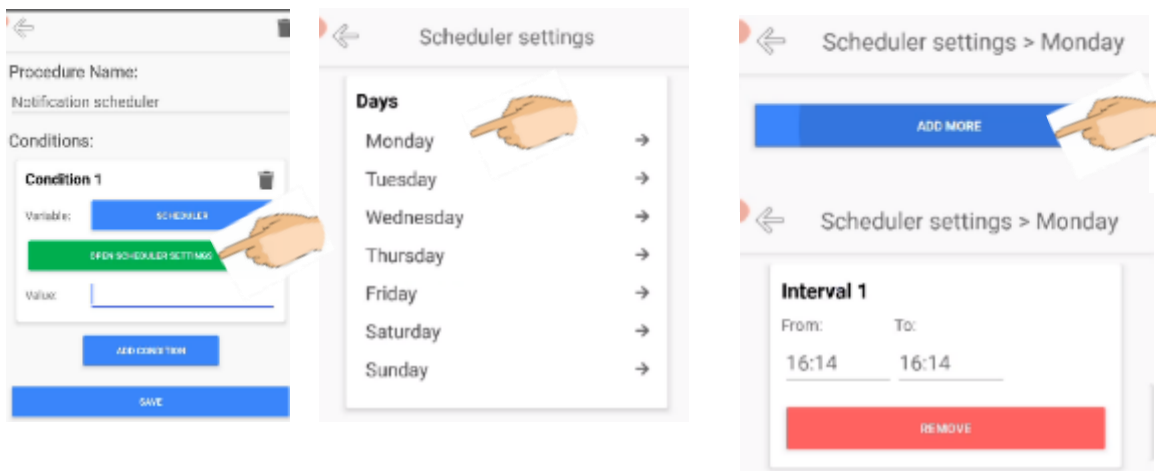

4. Modify the interval time “from” (when to start your operation) and “to” (when to stop your operation). E.g. 10:00 to 16:00. You have to manually change this for each day of the week. And press “OK”.

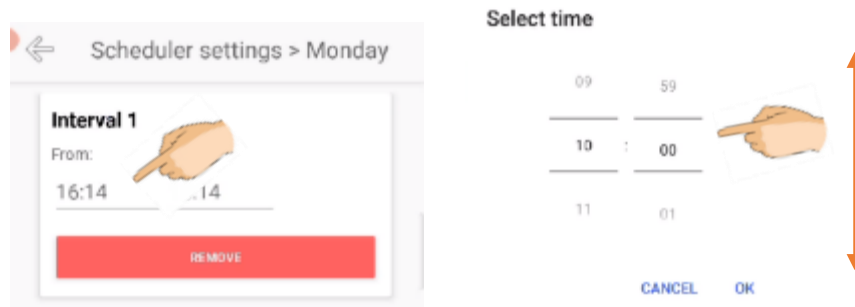

5. Once that's complete just navigate back to your Procedure settings and press save. After that you can go back to your pool settings and follow the instructions below to add an alarm notification.

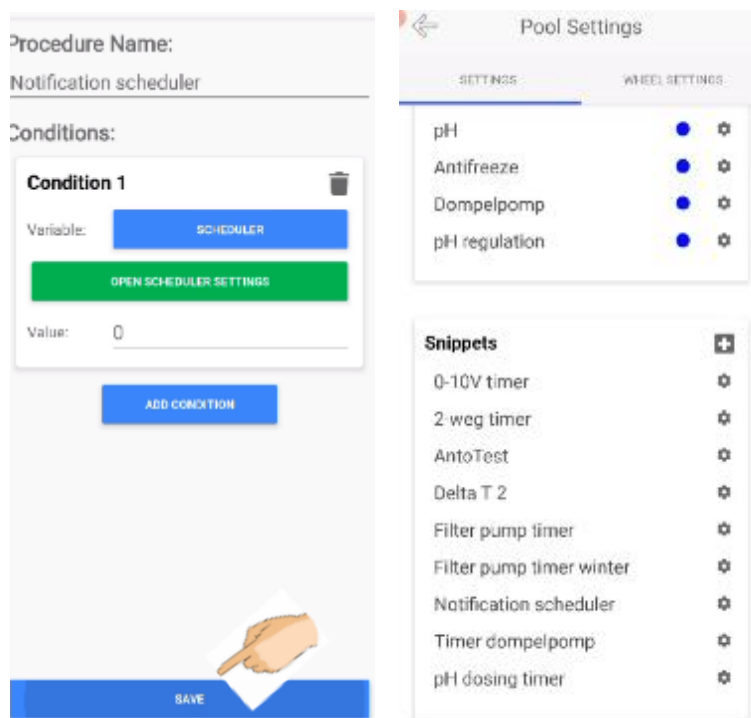

Adding alarm notification.

Make sure you also add an alarm notification in the manually entry itself.

6. In automations press the plus icon tab manual automation entry. Change the procedure name (e.g. pH > 9 alarm) and press “select device”.

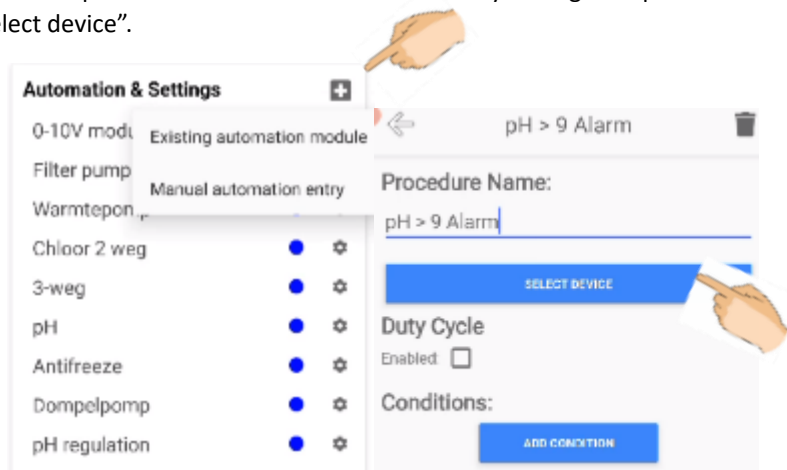

7. In select open “Alarm notification”. And change alarm message (e.g. pH > 9). Make sure to tab “add condition” and select, for example, your pH module.

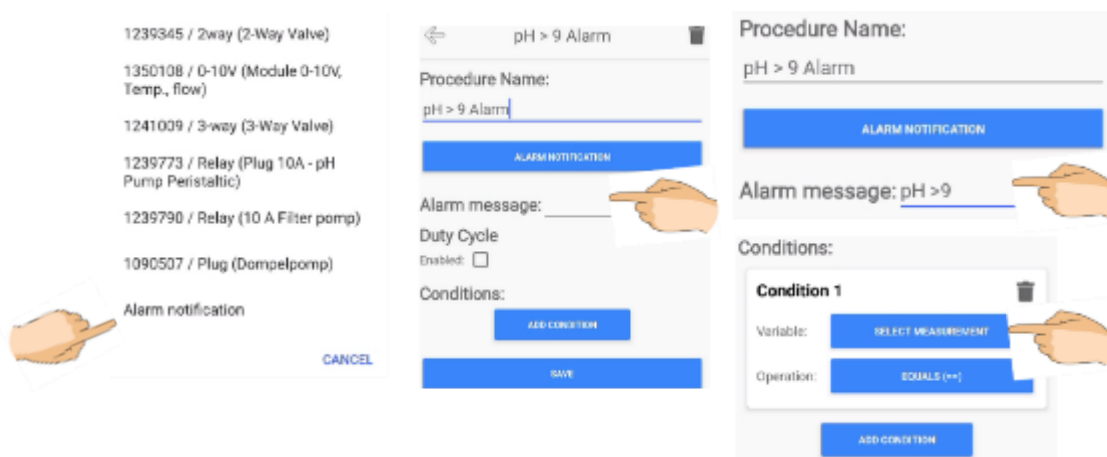

8. In here you can modify your operation and value.

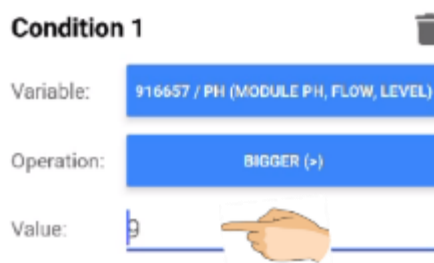

9. Finally press save.

3.5. Wheel Setting

Via the wheel setting page, you will be able to modify how the wheel on the main page looks like. You can choose icons, change the order, decide what you see and don't see in the wheel.

Via the wheel page, you can access the graphs pages.

As a special feature, you will be able to set the « fail safe » of your action devices.

You can access the wheel settings page via 2 routes :

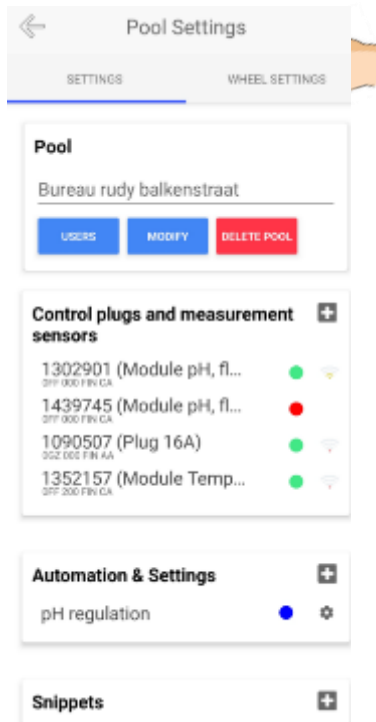
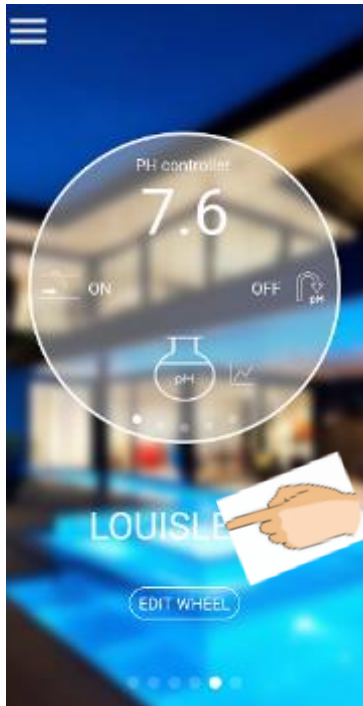

On Android phones

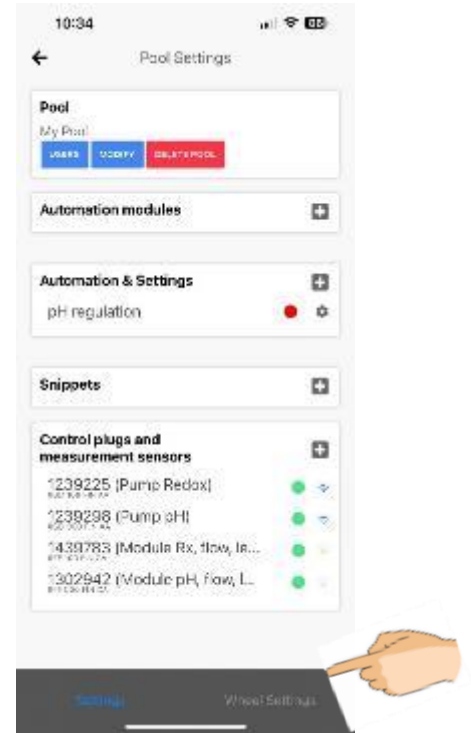

On iPhones

In the wheel, 3 variables are visible. By tapping the arrows, you can scroll through the pool variables displayed on the wheel. By tapping the graph symbol, you will see the graphical display of the last hour / 24H/3 days / week.

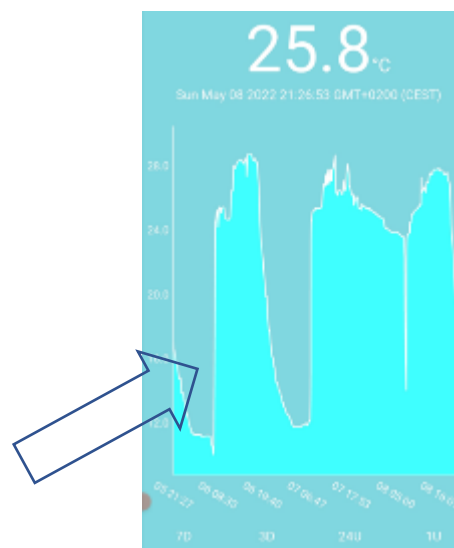
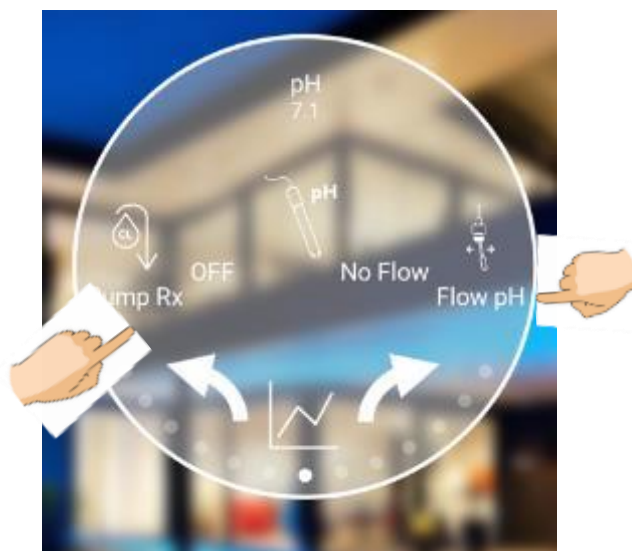

3.5.1. Wheel editing

Drag the items you want to make visible on your wheel dashboard from not visible to visible, by grabbing and dragging the 3 thin lines (sometimes you will need to hold your finger 3 seconds before dragging) at the right corner of your device. Make the reverse operation to make “invisible” items visible.

Moving items up or down within the visible zone, will change the order in which the devices are displayed on the wheel

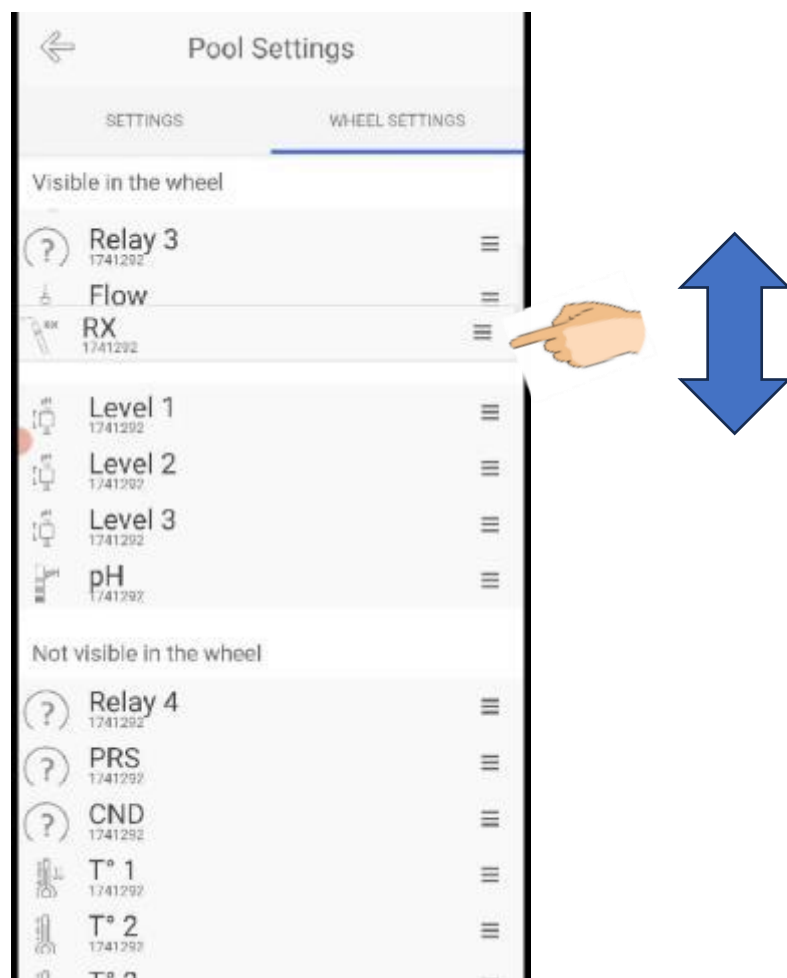

3.5.2. Icon selection

Tap on the device name in the “Wheel setting” page.

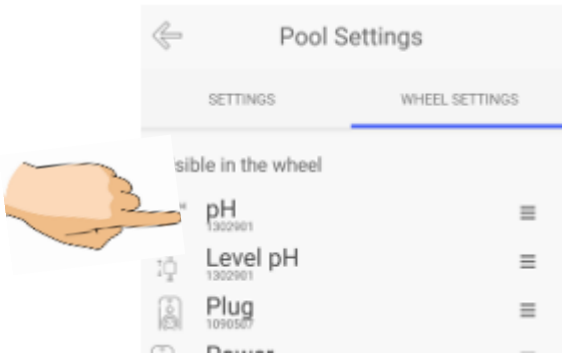

Select your favorite icon for your device. Go back by clicking on the top left corner arrow

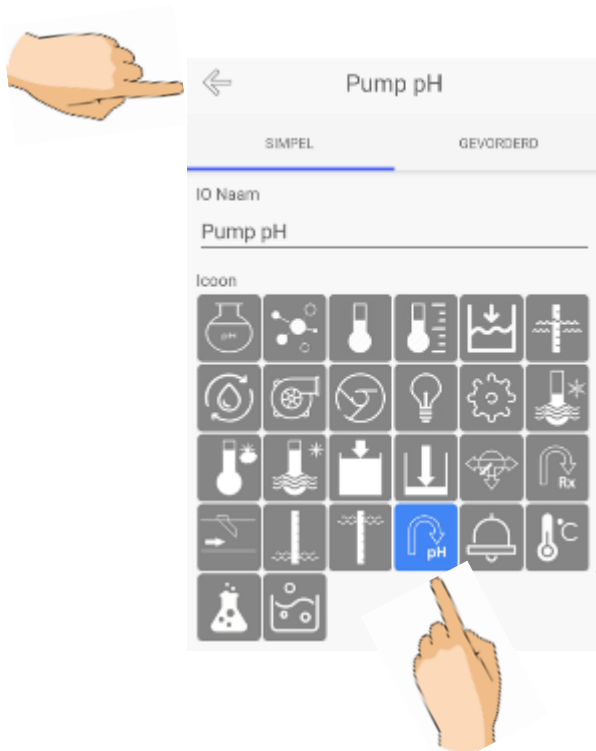

3.5.3. Failsafe mode

The Failsafe mode is used to define, what the device has to do in case wifi (or other) connection is lost : stop working or continue to work.

The failsafe mode can only be set for “action devices” such as plugs ,smart switches, pumps and automatic valves and not for measurement boxes.

To enter the failsafe menu, tap on the name of the device name once, followed by “advanced”.

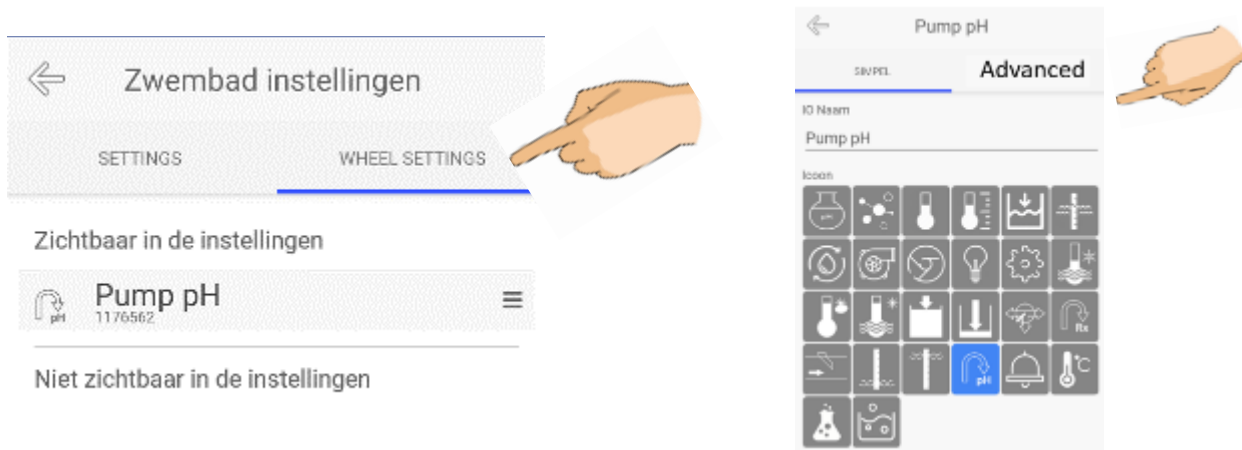

On the safety mode page, we can enter value 0 or 1.



At a failsafe setting of 0, the plug or smart switch will turn OFF during a system failure (e.g., loss of Wi-Fi). This setting is suitable for devices like a pH peristaltic pump. During a Wi-Fi loss, the pump needs to stop pumping.

At a failsafe setting of 1, the plug or smart switch will turn ON during a system failure (e.g., loss of Wi-Fi). This setting is appropriate for a winterizing filter pump, programmed to operate when outside temperatures drop below 2°C. If Wi-Fi is lost, the pump needs to continue running to prevent freezing.

Caution = be aware of the risk when switching failsafe on or off.

Example: set the pH dosing pump to failsafe 1, can cause pH- to be pumped nonstop to your swimming pool when internet connection is lost

The failsafe mode can only be set for “action devices” such as plugs ,smart switches, pumps and automatic valves and not for measurement boxes.

3.6. Action devices : Plugs and switches

Gen 2

In gen 2, there are no plugs or switches bur relays built right into the device itself. The Gen 2 connects straight to its power supply, as well as the pH pump and RX pump, making everything simple and straightforward.

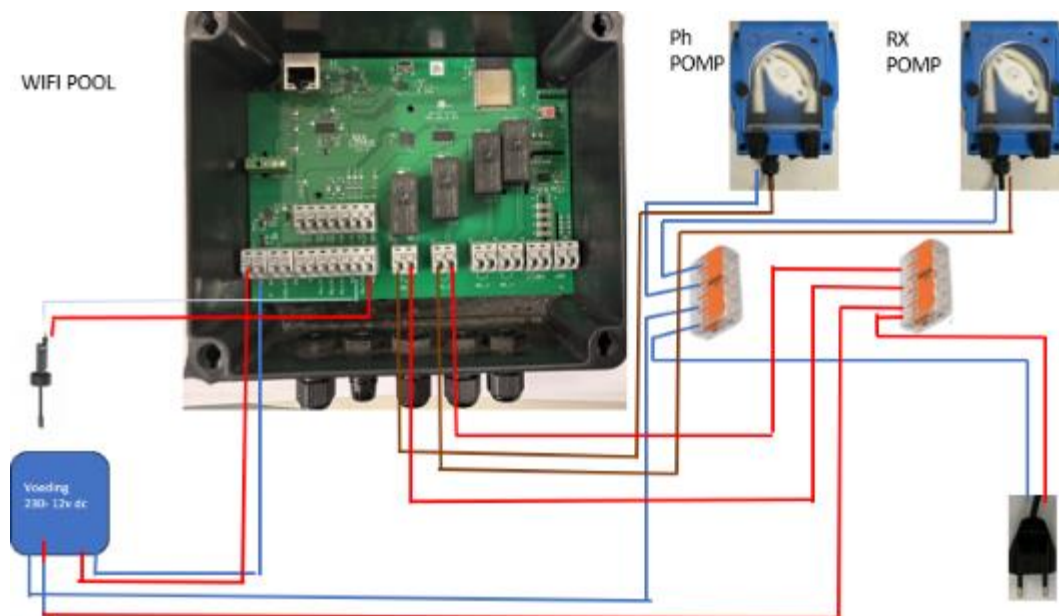

Gen 1:

Action devices, are devices with which you can start, stop, activate or deactivate a piece of equipment.

The Wifipool products are compatible with Shelly action devices, but only when the Wifipool software has been injected in the shelly devices

3.6.1. Plugs



Control plug 16A



Control plug 10A

The plugs operate on 230V

These plugs and switches will allow a pool equipment, such as a filter pump, UV lamp, peristaltic pump etc. to switch on or off. They are excellent for retrofitting existing equipment (such as a filter pump, peristaltic pump, lighting etc.) in the Wifipool app.

The plugs measure the power consumed.

3.6.2. Smart switches



Smart switch 16A



Smart switch 16A



Smart switch Plus 2 PM

Depending on the smart switch, they operate on 12, 24 and/or 230V.

These switches will allow pool equipment, such as a filter pump, UV lamp, peristaltic pump etc. to switch on or off. The Shelly smart switch 2 PM is used to switch a piece of equipment (e.g. an automatic valve) between position A and B. In some cases you will find these switches “hidden” in the Wifipool equipment.

Only the “red” smart switch; measures the consumed power.

The smart switches need to be connected to the pool equipment as follows :

Connection with on-off switch
For smart plug ZWPX0010

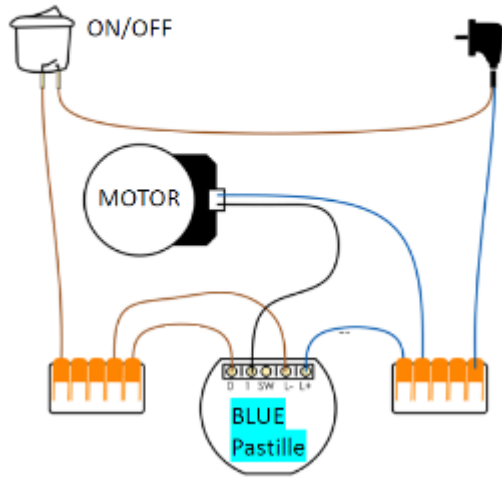

Connection without on-off switch
For smart plug ZWPX0010

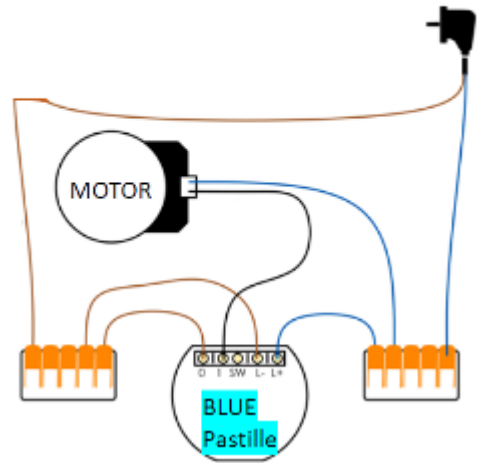

Connection with on-off switch
For smart plug ZWPX0020

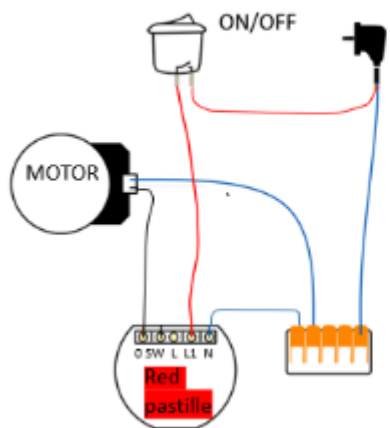

Connection without on-off switch
For smart plug ZWPX0020

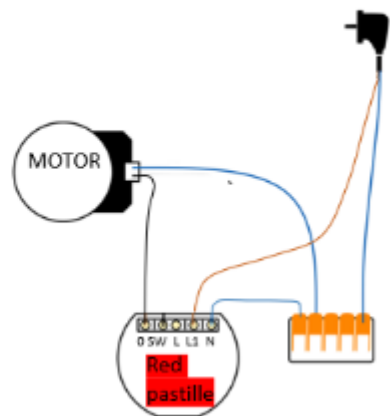

Equipment dependant
open/close connections

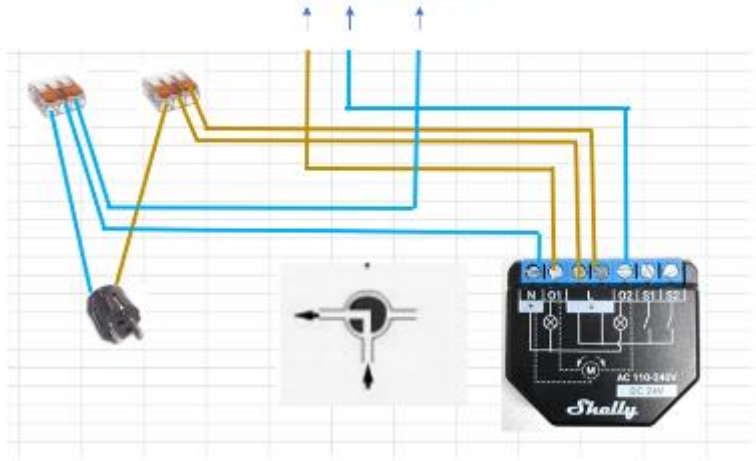

For the Shelly 2PM module,
the exact wiring depends on
the specific product.

3.7. Measurement devices

3.7.1. pH, RX and Temp

Our system contains 3 measurement boxes



pH, level, flow



Redox, level, flow



Temperature (x2), level, flow (TLF)

The units operate on a 5V USB plug, and consume less than 1 Amp.

The pH and RX probes have a regular and standard BNC connection

Level switch, flow switch and temperature probes have a male/female 3 or 2 pole water-tight Higo connection which are color coded so no mistake is possible.

These measurement boxes will allow you to measure various pool characteristics, which will be displayed on the mobile phone. Via the automation menu, it will be possible to steer the plugs and smart switches, depending on the measurements.

When adding a new measurement (flow or level switch) : disconnect the measurement box from the power, plug in the sensor, and connect to the power while the sensor is off position (no flow, low level)

For the temperature measurement box, it is necessary to plug in the measurement probes, before connecting the box to the power. If you see that the outside temperature and water temperature are "switched", then unplug the temp unit from the power, switch the temperature probes and plug the temp module into the power.

3.7.2. Combined measurement and control devices

3.7.2.1. 0-10V and 4-20mA

The 0-10V and 4-20mA modules contains both a “action” part and a “measurement part”

The modules can emit a constant voltage between 0 and 10V, or a constant current between 4 and 20mA. The modules can be used to control a external device.

The frequency regulator is controlled by applying a voltage to the regulator, where 0V = 0 rpm and 10V = 2950 rpm.



Both modules have one flow and two temperature measurement connections.

3.7.2.2. All-in Gen 2 – 2024

In gen 2 there are no more plugs and switches to worry about. Now, everything you need is built right into the device itself.



In a Gen 2 equipment , there are following measurements :
pH, RX, temperature (x3), level (x2), flow, pressure and conductivity (salt content).

There are 4 relays which can control 12-240V powered devices.

Additionally, Gen 2 introduces new connectivity options. Alongside Wi-Fi pairing, there's now Ethernet pairing available. While Wi-Fi is an option, it's important to note that the company prefers Ethernet connections. In the event of Wi-Fi issues, users may be subject to charges, so it's recommended to utilize Ethernet for optimal performance.

Not only is Gen 2 more connected, but it's also quicker to install. In previous generations, users had to scan each module separately during setup. However, with Gen 2, only one barcode needs to be scanned, and it's ready to go. This streamlined process minimizes installation time and hassle, getting users up and running faster than ever before.

Moreover, Gen 2 comes equipped with preprogrammed automations, further enhancing its user-friendly nature. These built-in automations simplify tasks and workflows, providing added convenience and efficiency for users. With Gen 2, automation is at your fingertips, ready to streamline operations and maximize productivity.

4 Problem Solving

4.1 Resetting your Wi-Fi equipment

After a “miscommunication” between cloud and device, it may be necessary to reset your device. To reset your smart plug you have to follow the Reset Procedure.

Gen 2:

To reset your Gen 2 WiFiPool device, please follow these detailed steps:

1. Open the Lid: Start by carefully opening the lid of your WiFiPool device. This will give you access to the internal components.
2. Locate the Red Button on the PCB: Once the lid is open, locate the red reset button on the printed circuit board (PCB). It is essential to identify this button correctly to proceed with the reset process.

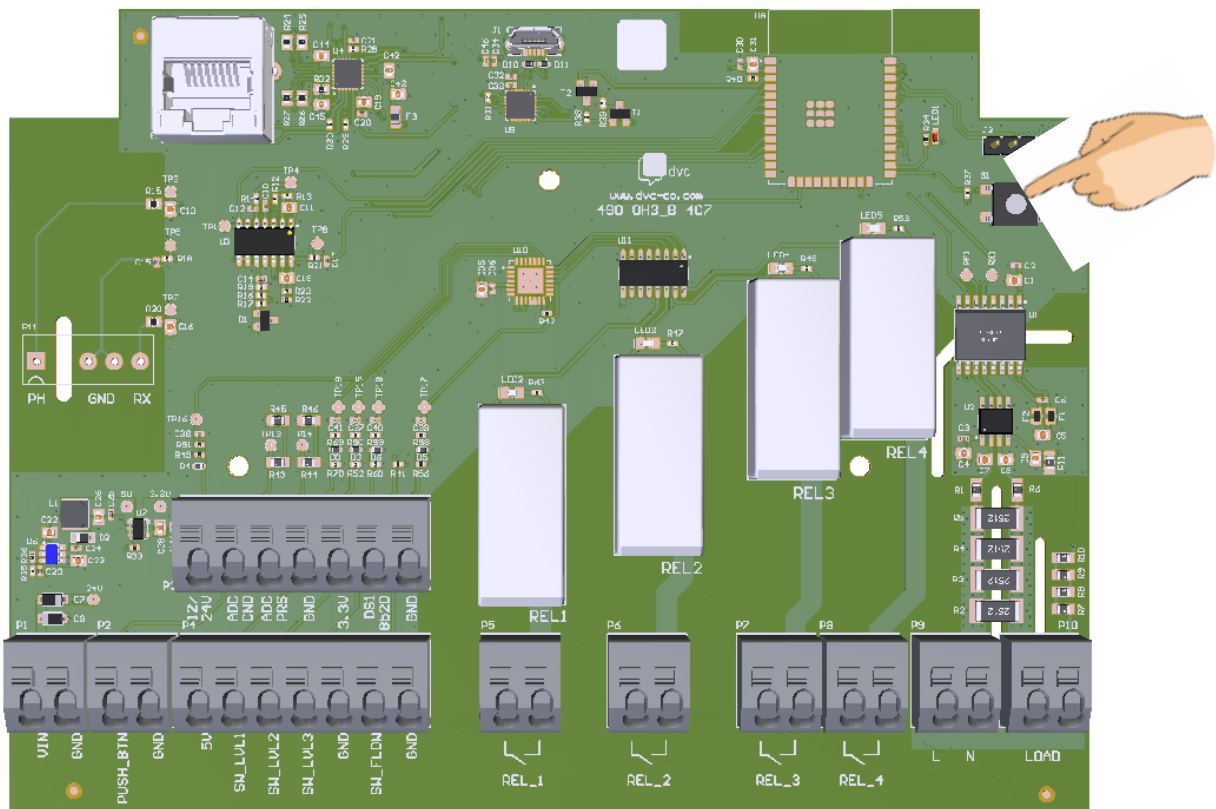

3. Hold the Reset Button: Press and hold the red reset button for exactly 40 seconds. Use a timer or a stopwatch to ensure that you hold the button for the full duration. Timing this step accurately is crucial for a successful reset.
4. Verify the Reset: After holding the reset button for 40 seconds, release it and observe the device. The reset process should now be complete.
5. By following these steps, your WiFiPool device should be successfully reset and ready for use.

Gen 1:

- Plug your smart plug in the outlet
- Plug out the USB for 10 sec
- Plug in-out the plug 7x

1. Plug your USB briefly in (1sec) and then pull out your USB for 2 Sec
2. Plug your USB briefly in (1sec) and then pull out your USB for 2 Sec
3. Plug your USB briefly in (1sec) and then pull out your USB for 2 Sec
4. Plug your USB briefly in (1sec) and then pull out your USB for 2 Sec
5. Plug your USB briefly in (1sec) and then pull out your USB for 2 Sec
6. Plug your USB briefly in (1sec) and then pull out your USB for 2 Sec
7. Plug your USB in and leave it in on the 7th time



Repeat 7 X



The same procedure applies also for the smart plug



Repeat 7 X



... procedure correctly than y... app and scan for devices : your phone will be searching for the plug.

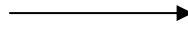
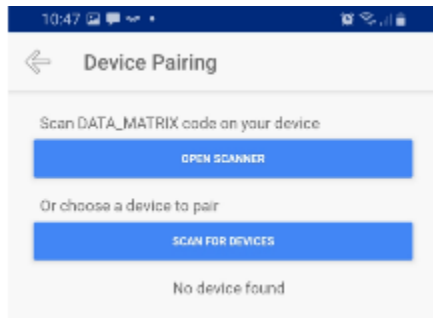

4.2 Notifications do not arrive consistently

On most devices, an app has background processes that allow it to do things like get notifications, which will remain active even when the app is closed.

Certain manufacturers (including OPPO & Xiaomi) have made their own versions of Android for their devices, so that notifications are not forwarded or only occasionally.

Fortunately, the settings that ensure that the app cannot forward notifications can be adjusted. The following article explains how you can make these adjustments for various devices (including of course OPPO) and thus hopefully receive the notifications as expected: <https://help.pushwoosh.com/hc/en-us/articles/360028478751-Android-device-cannot-receive-push-notifications-when-an-application-is-force-stopped-killed->

4.3 Pairing

Pairing problems have been addressed above

4.4 Contact troubleshooting

For troubleshooting, contact your supplier or contact info@beniferro.eu .

To make sure you can be helped efficiently, make sure info@beniferro.eu has become a user level co-owner of your pool (see section 3.1.1.2)

Appendices

Appendix 1: Preprogrammed Automations

In Gen 2, automations occur automatically after pairing your device. These are already set up by the system upon installation.

You can view the preprogrammed automations in "Automation & Settings". Most of these preprogrammed automations are based on conditions that work for most pools. Automations ensure that your modules are activated when certain conditions are met. For example, if your pH level is above 7.6, then your pH pump will start, or when there's flow or no flow, high or low redox levels, etc.

You can manually modify these automations or add your own. To modify the automations, tap on the automation title, and in the menu, you can adjust the conditions to your preferences. Only modify these settings if you understand what you're doing.

To create new automations, simply tap the plus icon and follow similar steps to modification as described in the previous paragraph.

For Gen 1 devices, preprogrammed automations exist but these need to be scanned in via a barcode. See the quick start manual of the device purchased.

Appendix 2 : Pairing instruction sheet example

Pairing and automation Wifipool water treatment

Thank you for choosing our Wifi water treatment. For an easy and quick start, we recommend the following:

1 Install the wifipool app. Instructions for installing the app can be found in the attached Wifipool App Quick Start Guide and Simple Equipment.

2 Pair the device with your phone

It's best to do this indoors in an area with a good Wi-Fi network connection (the same network you'll use for your pool) and a modem with a network cable connection (ethernet cable)

3 Connect the Wifipool control box to your modem via a network cable (ethernet cable) and start pairing. If you want to pair over a Wi-Fi connection (not recommended), refer to the Wifipool App Quick Start Guide and Simple Equipment. Please note: Beniferro does not provide free support for pairing via Wi-Fi, if you have a device with a network cable connection

3.1: Go to the "Pool Settings" app page,
tap on the plus icon next to
"Sockets & Measurement Sensors".

3.2: Select "Scan" and scan this
barcode:



3.3: Select the Wi-Fi network you want to use for your pool equipment

Once pairing is complete, you can continue with or without a network cable. Without a network cable, a good connection to your Wi-Fi network is required.

4 During pairing, automation was also loaded.

5 Once you've calibrated the pH and RX sensors, you're ready to use your device.

Appendix 3a : Gen 2 technical specifications

ETHERNET CONNECTION	Desired for pairing Possible for daily operation
STABLE WIFI	Required if ethernet cable is not available - standard extender or powerline compatible
WIFI CONNECTION PROTOCOL	802.11b, 802.11g and 802.11n
WI-FI RADIO FREQUENCY	2412 - 2484 MHz
WI-FI RADIO SIGNAL POWER	<1mW
WIFI DISTANCE OUTDOORS	up to 50 m outdoors and up to 30 m indoors (depending on the building materials)

PCB WITH ETHERNET CONNECTION – GEN 2	pH, RX measurement Extendible with Temperature measurement (x3), flow switch, level switch(x3), pressure measurement, conductivity measurement 4 ON-OFF relays 12-240V
TEMPERATURE SPECIFICATION	-20°C to + 70°C
CONFIGURATION	Via mobile phone (preconfigured)
AVAILABLE LANGUAGES	NL, EN, FR, DE, IT, ES
RELAY CONTROL	12-240V
POWER SUPPLY	12-240V(relai) 12 or 24V (PCB power)

Appendix 3 b : Gen 1 technical specifications

STABLE WIFI	Required - standard extender or powerline compatible
WIFI CONNECTION PROTOCOL	802.11b, 802.11g and 802.11n
WI-FI RADIO FREQUENCY	2412 - 2484 MHz

WI-FI RADIO SIGNAL POWER	<1mW
WIFI DISTANCE OUTDOORS	up to 50 m outdoors and up to 30 m indoors (depending on the building materials)

TEMPERATURE SPECIFICATION	-20°C to + 70°C
CONFIGURATION	Via mobile phone (preconfigured)
AVAILABLE LANGUAGES	NL, EN, FR, DE, IT, ES

ETHERNET CONNECTION	Desired for pairing Possible for daily operation
STABLE WIFI	Required if ethernet cable is not available - standard extender or powerline compatible
WIFI CONNECTION PROTOCOL	802.11b, 802.11g and 802.11n
WI-FI RADIO FREQUENCY	2412 - 2484 MHz
WI-FI RADIO SIGNAL POWER	<1mW
WIFI DISTANCE OUTDOORS	up to 50 m outdoors and up to 30 m indoors (depending on the building materials)

PCB WITH ETHERNET CONNECTION – GEN 2	pH, RX measurement Extendible with Temperature measurement (x3), flow switch, level switch(x3), pressure measurement, conductivity measurement 4 ON-OFF relays 12-240V
TEMPERATURE SPECIFICATION	-20°C to + 70°C
CONFIGURATION	Via mobile phone (preconfigured)
AVAILABLE LANGUAGES	NL, EN, FR, DE, IT, ES
RELAY CONTROL	12-240V
POWER SUPPLY	12-240V(relai)

12 or 24V (PCB power)